



# Installation Instructions

## VI-COWL

Product Number: VC3100

2016-2019 GMC 2500-3500

---

## SAFETY

---

### Your safety and the safety of others is very important.

- In order to help you make informed decisions about safety, we have provided installation instructions and other information.
- These instructions alert you to potential hazards that could hurt you or others.
- Please do a job safety analysis (JSA) before each task to identify potential hazards for your situation and remove/protect against them.
- You must use your own good judgment, and take your time.

**Read and understand all safety precautions and instructions before installing this product.**

THIS PRODUCT IS FOR OFFROAD USE ONLY. ALL LIABILITY FOR INSTALLATION AND USE RESTS WITH THE OWNER.

**CARELESS INSTALLATION AND OPERATION CAN RESULT IN SERIOUS INJURY OR EQUIPMENT DAMAGE.**

---

## Injury hazard

---

### Failure to observe these instructions could lead to severe injury or death.

- Always** remove jewelry and wear eye protection.
- Always** use appropriate and adequate care in lifting components into place.
- Always** insure components will remain secure during installation and operation.
- Always** wear safety glasses when installing this kit
- Always** use extreme caution when cutting and trimming during fitting.
- Always** tighten all nuts and bolts securely per installation instructions.
- Always** perform regular inspections and maintenance on mounts and related hardware.





# Installation Instructions

## VI-COWL

Product Number: VC3100

2016-2019 GMC 2500-3500

## Overview

Congratulations on your new purchase of the Fab Fours Vi-Cowl Accessory.

Your Vi-Cowl was designed in 3-D from digitized data, CNC laser cut, fabricated, and powder coated... all in the U.S.A. Enjoy the fit and finish of a Vi-Cowl from Fab Fours, Inc.

**WARNING:** This product was designed to be used with the 16-19 GMC 2500/3500.

## Contents

### SAFETY

Injury hazard

Overview

- I. Tools Required
- II. Factory Vehicle Prep
- III. Wiper cowl modification
- IV. Fab Fours hood hinge installation
- V. Hood Installment
- VI. ViCowl Pre-Assembly
- VII. ViCowl Installation
- VIII. Maintenance/Care





# Installation Instructions

## VI-COWL

Product Number: VC3100

2016-2019 GMC 2500-3500

### I. Tools Required

- 3/16" Allen Wrench
- Open End Wrench
- Socket Set and Ratchets
- Scissors
- Drill Bit – 1/4"
- Blue Painters Tape
- Knife
- Pick or Small Flat Head Screwdriver

### II. Factory Vehicle Prep

- a. Apply Blue tape on each side of the hood and fender. Mark the tape with a straight-line perpendicular with the hood and fender body seam. Use a knife to cut the tape along the same seam.

Note: Step one is recommended to assist you in realignment of the hood during reassembly.

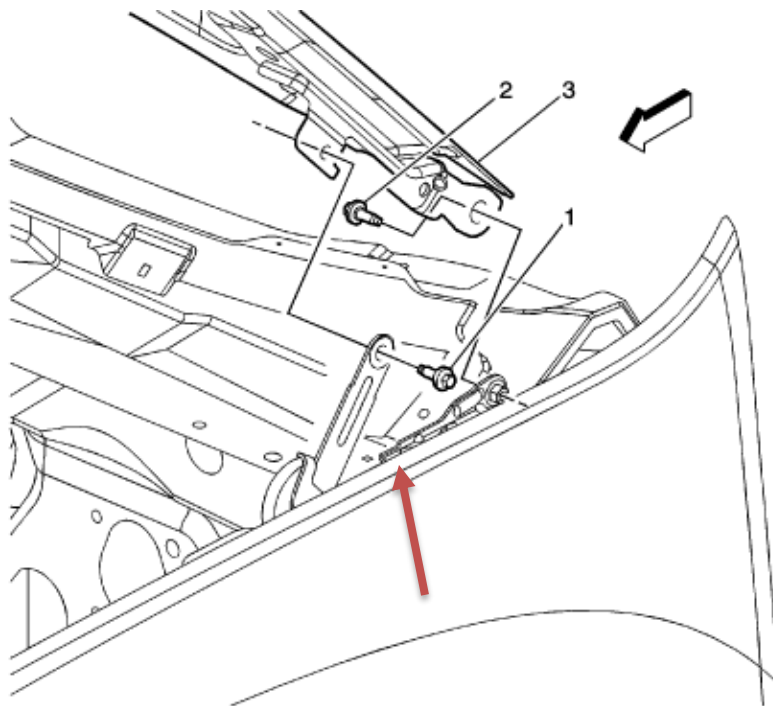

Fig 1





## Installation Instructions

### VI-COWL

Product Number: VC3100

2016-2019 GMC 2500-3500

- b. Loosen the four bolts that secure the hood to the upper hood hinge bracket, so they can be removed by hand.
- c. Disconnect any electrical connections if your vehicle is equipped.
- d. With a friend on the other side, support the hood and fully remove the hood bolts and remove the hood.
- e. Remove and save bolts labeled (1&2) from **Fig 1**.
- f. Remove the front bolt on fender indicated at red arrow from **Fig 1 and 2**.
- g. Set the OEM hood hinge bracket aside, it won't be used again.

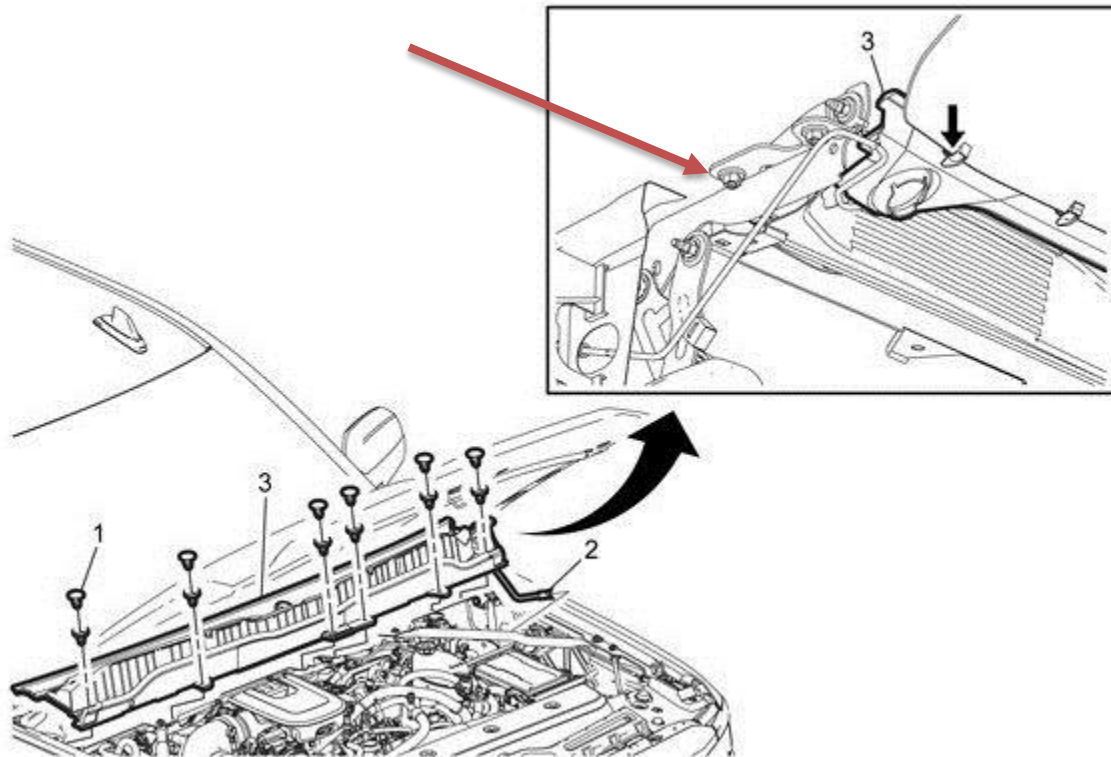

**Fig 2.**

- h. Remove the 6 plastic retainers labeled (1) in **Fig 2**.
- i. Remove the wiper arms.
- j. Disconnect the wiper fluid supply line from the wiper cowl labeled (2) in **Fig 2**.
- k. Unclip the wiper cowl from the windshield by sliding the cowl down along the windshield until its loose from the glass.
- l. Remove the cowl and set aside for trimming.





# Installation Instructions

## VI-COWL

Product Number: VC3100  
2016-2019 GMC 2500-3500

### III. Wiper Cowl Modification

- a. Both ends of the cowl need to be trimmed so that the ViCowl brackets clear the cowl in the down position.

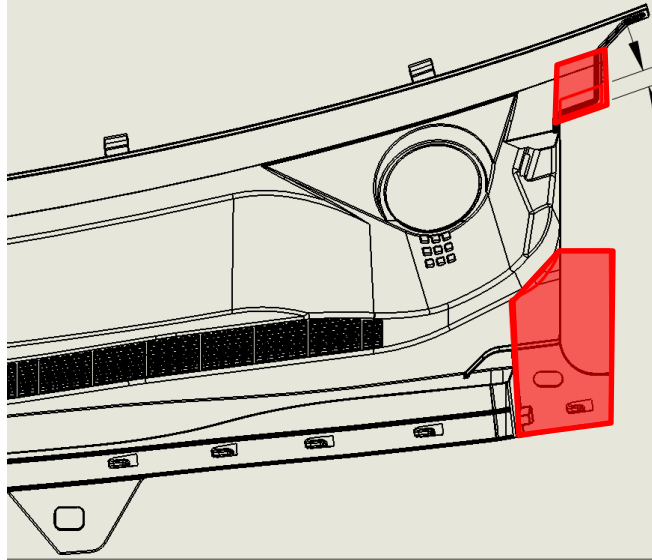

**Fig 3**

- b. Trim off the areas indicated with the outlines in **Fig 3** on the driver side of the cowl

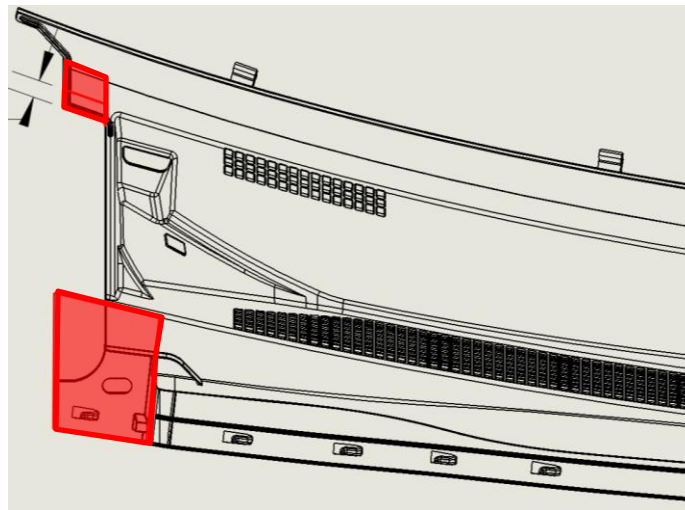

**Fig 4**

- c. Trim off the areas indicated with the outlines in **Fig 4** on the passenger side of the cowl.

**Note:** some minor additional trimming may be needed in areas marked to cut.





## Installation Instructions

### VI-COWL

Product Number: VC3100

2016-2019 GMC 2500-3500

## IV. Fab Fours Hood Hinge Installation

**Note: Both driver side and passenger side brackets install the same way.**

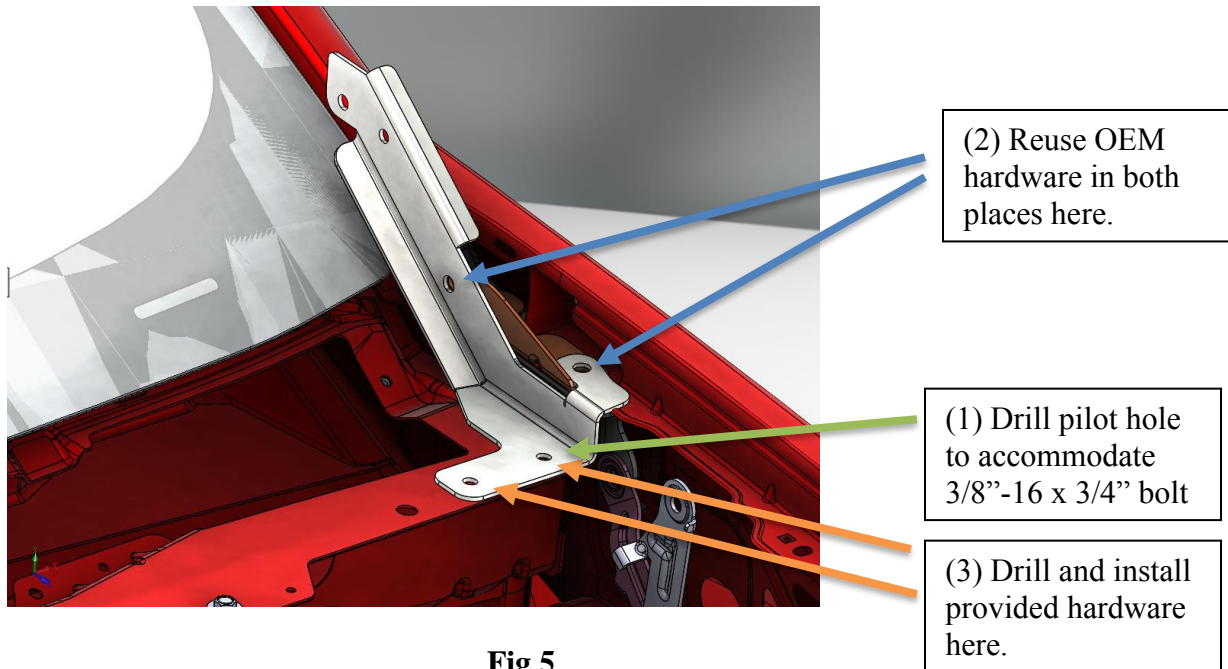

**Fig 5**

- Drill hole to 3/8" using factory hole as drill pilot as shown in **Fig 5** item (1).
- Position the driver side bracket as pictured in **Fig 5**.
- Loosely install the two factory bolts as shown in **Fig 5** item (2).
- Install the outer 3/8"-16 x 3/4" zinc bolt, washer, and Nylock nut in the hole that was drilled out as indicated in **Fig 5** item (1).
- Fully tighten down the two factory bolts followed by the 3/8"-16 x 3/4" bolts.
- Mark and remove bracket or just drill out the remaining hole indicated in **Fig 5** item (3).
- Repeat the same procedure for the passenger side bracket.

**\*\*Note: When Drilling the #3 locations shown above in Fig 5 on the driver's side and passenger's side, use a scrap piece of metal under the drilling area to protect the coolant reservoir and wiring harnesses from contact with the drill bit. These can also be temporarily relocated to avoid contacting them during the drilling operation. \*\***





## Installation Instructions

### VI-COWL

Product Number: VC3100

2016-2019 GMC 2500-3500

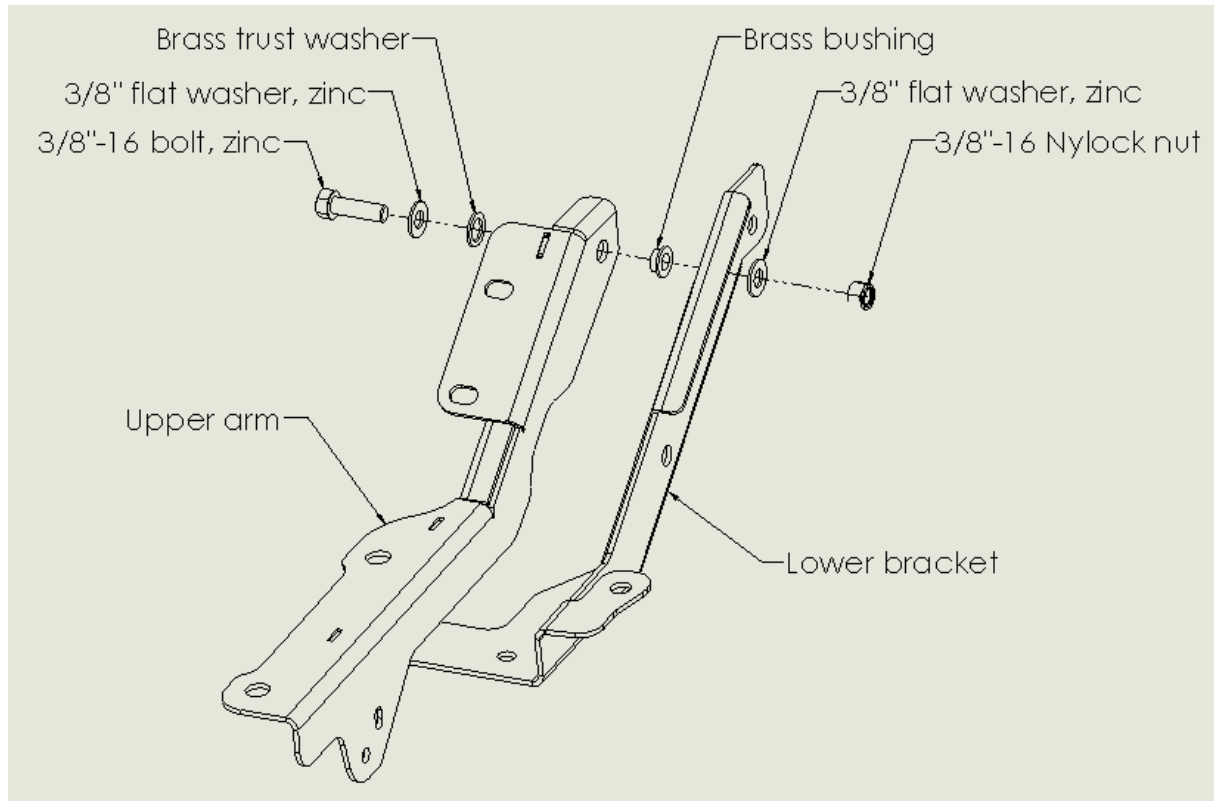

**Fig 6**

- h. Press install the brass bushing into the upper hole in the Upper arm as shown in **Fig 6**.
- i. Insert the 3/8"-16 x 1.25" bolt with washer and thrust washer into the brass bushing as shown in **Fig 6** forming the upper arm sub assembly.
- j. Insert the upper arm sub assembly into the lower bracket hole with washer and 3/8"-16 Nylock nut.
- k. Holding the upper arm and bolt stack tight to the lower bracket, tighten the Nylock nut being careful that the thrust washer doesn't pop out from the brass bushing.





## Installation Instructions

### VI-COWL

Product Number: VC3100

2016-2019 GMC 2500-3500

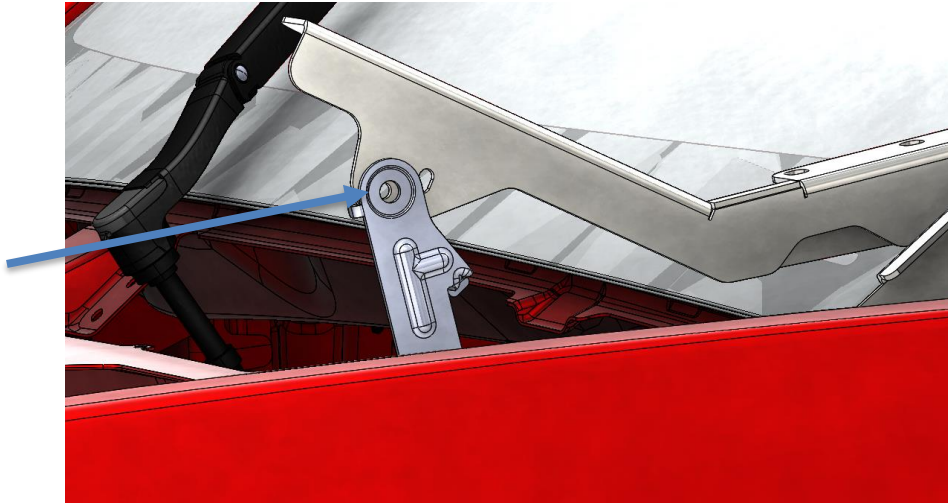

**Fig 7**

1. Bolt the hood spring assist arm to the upper arm of the hood hinge using the factory bolt and included stainless steel flat washer and M8 Nylock nut as shown in **Fig 7**.

**Note: Be careful not to use the 5/16"-18 Nylock nut here. The 5/16"-18 and M8 nuts are similar in size and appearance. To avoid confusion here, set aside all the 5/16"-18 Nylock nuts with the 5/16"-18 Stainless steel button head bolts and rubber bonded washers that will be used in the visor assembly later in the installation.**

## V. Hood Installation

- a. With a friend, lift the hood onto the upper arm of the hood bracket and install the four factory bolts hand tight.
- b. Align the upper arm with the missing paint marks made under the hood from the factory brackets. This will get you close as the Fab Four brackets have identical profile.
- c. Lower the hood slowly and check for uniform hood gap.
- d. Adjust as needed.
- e. Fully tighten down the four factory bolts.







## Installation Instructions

### VI-COWL

Product Number: VC3100

2016-2019 GMC 2500-3500

## VI. ViCowl Pre-Assembly

**Note:** It's highly recommended that all projection weld nuts are chased with the appropriate taps to insure a smooth installation prior to assembly.

Tap sizes needed to do this are  $\frac{1}{2}$ "-13, and  $\frac{3}{8}$ "-16

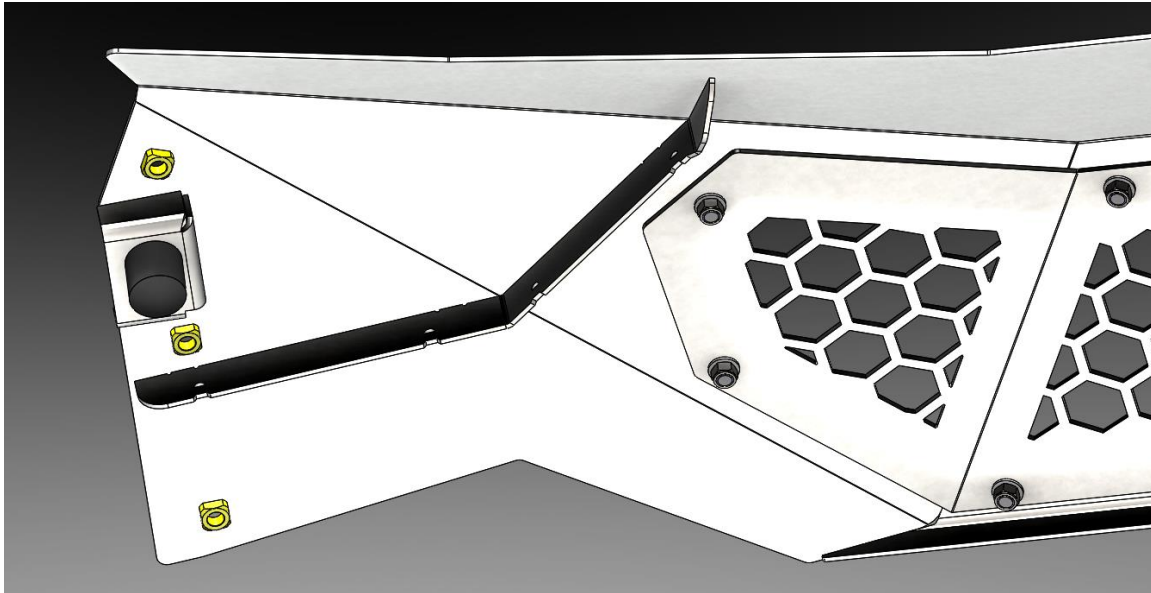

**Fig 8**

- Install and hand tighten the rubber bumpers and  $\frac{1}{2}$ " flat washers to the visor as shown in **Fig 8**.
- Install loosely the mesh insert (or light insert if purchased) into the back of the visor using the provided  $\frac{5}{16}$ "-18 stainless steel bolts, rubber bonded washer, flat washer, and  $\frac{5}{16}$ "-18 Nylock nut.
- Fully tighten all visor accessory hardware.

**Note:** The rubber bonded washer is used on the outside surface of the visor to reduce any damage to the finish.





# Installation Instructions

## VI-COWL

Product Number: VC3100  
2016-2019 GMC 2500-3500

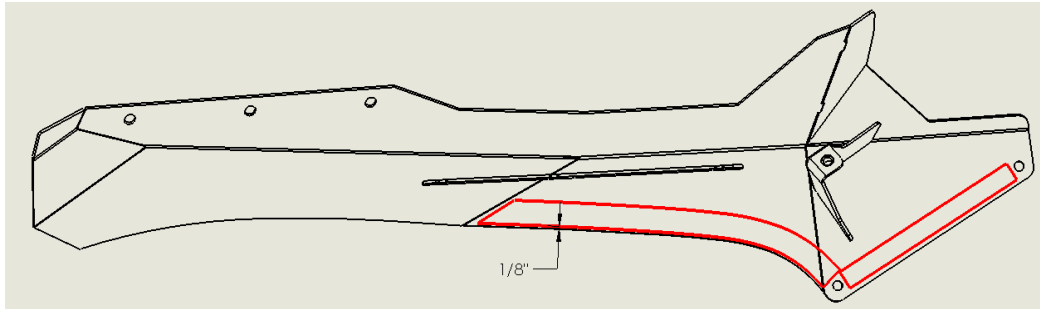

**Fig 9**

- d. Install the 1" neoprene rubber strip to the inside of both arms as shown in **Fig 9** highlighted areas.

**Note: Leave about a 1/8" reveal on the edge of the arms. This will ensure the rubber strip doesn't shift or show after installation.**

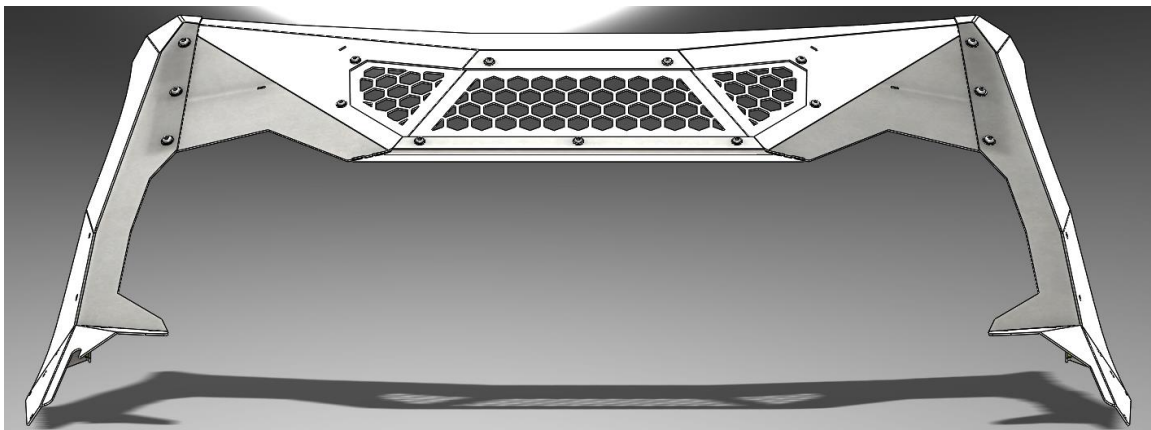

**Fig 10**

- e. Loosely install both ViCowl arms to the visor using the provided 3/8"-16 stainless steel bolts and rubber bonded washers as shown in **Fig 10**.

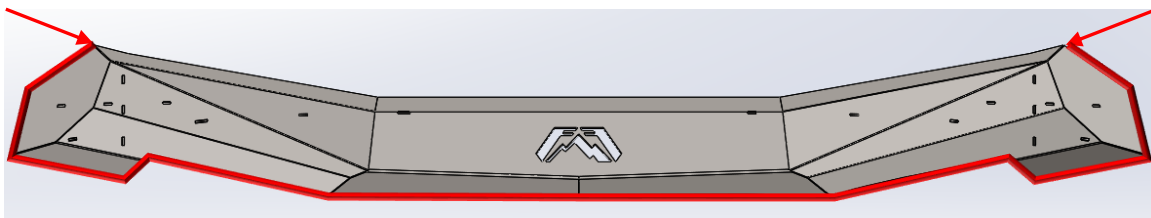

**Fig 11**

**Note: don't stretch the seal as you apply it to the Cowl. This will ensure it doesn't pull away from the sheet metal later.**





## Installation Instructions

### VI-COWL

Product Number: VC3100

2016-2019 GMC 2500-3500

- f. Install the edge seal with adhesive onto the leading edge of the cowl as shown in **Fig 11** by the bold line between the arrows.
- g. Trim the edge seal for fit and finish
- h. The ViCowl is now ready to be installed.

## VII. ViCowl Installation

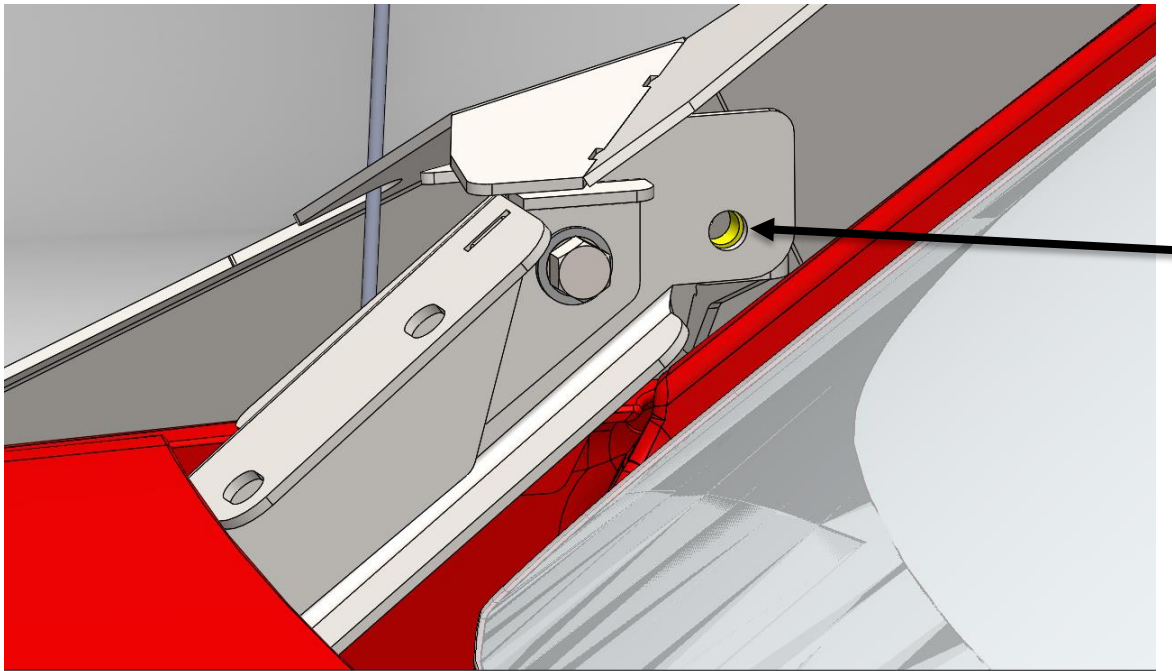

**Fig 12**

- a. With a friend on the other arm, lift the upper ViCowl assembly up over the hood and behind the radio antenna and slowly lower the arms into position. The arm mounting bracket rest to the outside of the lower hinge and lined up with the rear bolt hole as shown in **Fig 12**.
- b. Loosely install the  $\frac{3}{8}$ "-16 x 1.25" hex bolt, zinc lock washer, and zinc flat washer through the lower hinge bracket and into the arm securing the ViCowl from falling lower on the vehicle as indicated in Fig 12 with arrow.
- c. Check for fit and fully tighten down both arms to the hinge brackets.



## Installation Instructions

### VI-COWL

Product Number: VC3100

2016-2019 GMC 2500-3500

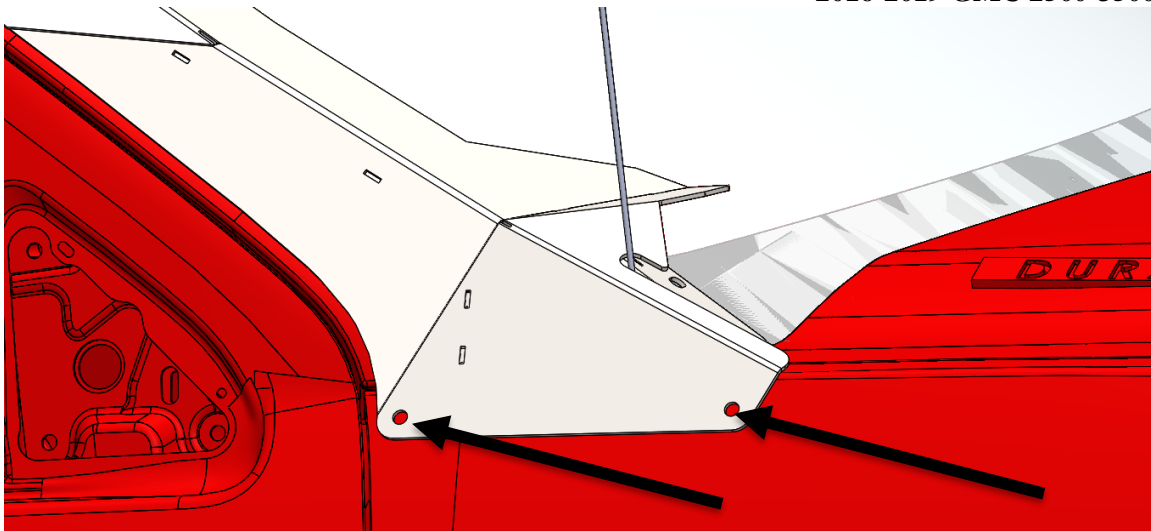

**Fig 13**

- d. Mark the two Rivet nut hole locations as indicated in **Fig 13** by the arrows and on both driver and passenger arms.

**Note: A high degree of accuracy is needed when marking the Rivet nut locations. The four Rivet nuts constitute a majority percentage of the mounting strength of the upper ViCowl to the vehicle. A hole center punch is recommended followed by incremental pilot holes to the finish hole size of the included 17/32" drill bit. You will have trouble lining up all three bolt holes per side if Rivet nuts are misplaced.**

- e. Remove the upper ViCowl assembly in preparation to drill and install four Rivet nuts in the fenders.
- f. Use the 1/8" Drill bit to drill pilot holes in all of the marked locations. Be careful to drill directly perpendicular to the side of the vehicle. In some instances, this will require drilling through multiple layers of sheet metal.
- g. Step up to the 1/4" drill bit.
- h. Final drill out the holes with the 17/32". If available, a sheet metal Uni-Bit or step drill bit can be used after the 1/4" Bit.
- i. With the expendable tool threaded into the rivet nut, insert it into one of the holes making sure that it fits in far enough to flush the collar of the rivet nut to rocker panel.
- j. Place the 9/16" Box end wrench on the body of the provided rivet nut tool and the 9/16" socket and ratchet on the bolt head on the back side of the tool. See **Fig 14** below.





## Installation Instructions

### VI-COWL

Product Number: VC3100

2016-2019 GMC 2500-3500



**Fig 14**

- k. Holding the open end wrench stable, tighten the socket wrench until you feel increased resistance. Then turn the socket wrench 1/4 turn more. **DO NOT OVERTIGHTEN OR THE RIVET NUT WILL FAIL.**
- l. Repeat steps “f-k” on the remaining holes.
- m. Reinstall the upper ViCowl using steps “a-b”
- n. Install the  $\frac{3}{8}$ "-16 stainless steel button head bolts, rubber bonded washers, and blue Locktight.
- o. Fully tighten down all hardware securing the upper ViCowl arms to the hood hinge brackets.



# Installation Instructions

## VI-COWL

Product Number: VC3100

2016-2019 GMC 2500-3500

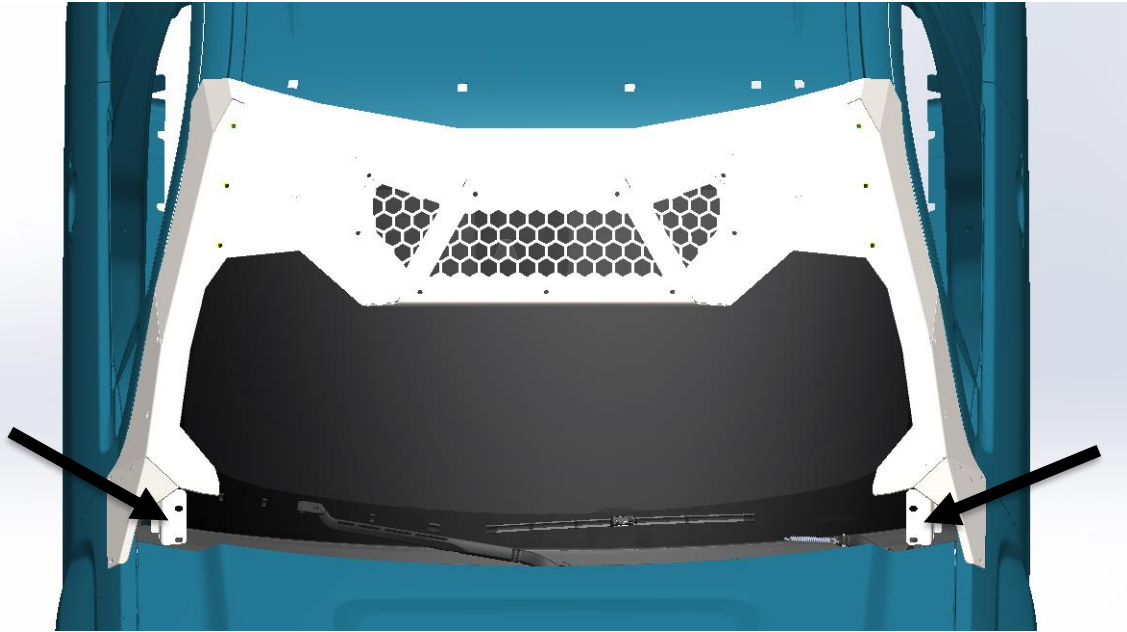

**Fig 15**

- p. With the help of a friend, lift the ViCowl cowl up over the hood and slowly lower it down on the mounting surface as shown in **Fig 15** with the arrows.

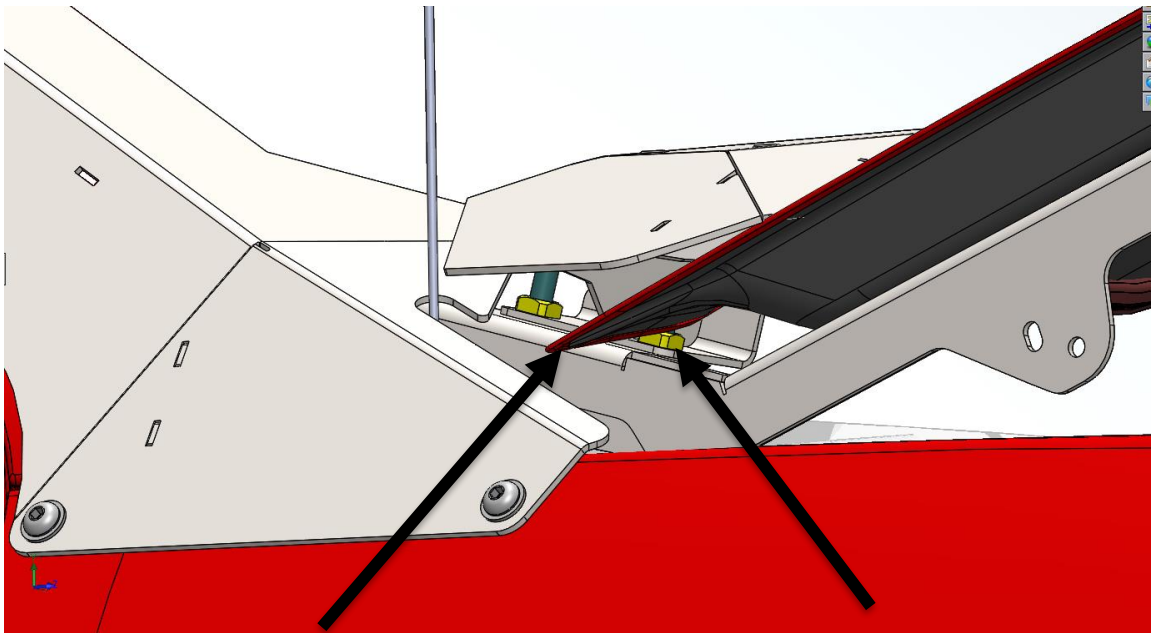

**Fig 16**



## Installation Instructions

### VI-COWL

Product Number: VC3100

2016-2019 GMC 2500-3500

- q. Raise the hood slowly and hand tighten the four  $\frac{3}{8}$ "-16 hex head bolts, zinc lock washers, and zinc flat washers securing the Cowl to the hood hinge brackets as shown in **Fig 16** with the arrows.
- r. Lower the hood and center it side to side and front to back insuring all gaps are even.
- s. Raise the hood and tighten the rear bolt on both sides first and then the front bolt. The bolt sequence will aid in closing any hood profile gaps that may be visible.

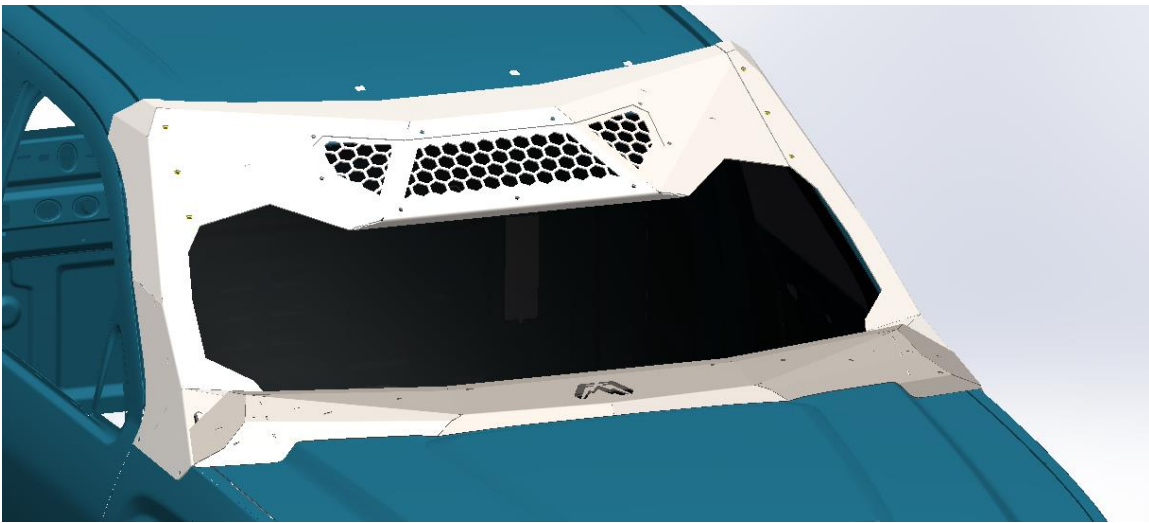

VC3100 hood cowl



## Installation Instructions

### VI-COWL

Product Number: VC3100  
2016-2019 GMC 2500-3500

#### VIII. Maintenance/Care

- Periodically check and tighten all nuts.
- Stripped, fractured, or bent bolts or nuts need to be replaced.



More than expected... Better than expected.

