

Made in the U.S.A.!



Installation Instructions

Nissan Titan [Winch](#) Mount with Pre-Runner

Product Number: N1750

Application: 2004-2013 Nissan Titan

SAFETY

Your safety and the safety of others is very important.

- In order to help you make informed decisions about safety, we have provided installation instructions and other information.
- These instructions alert you to potential hazards that could hurt you or others.
- Please do a job safety analysis (JSA) before each task to identify potential hazards for your situation and remove/protect against them.
- You must use your own good judgment, and take your time.
- **Read and understand all safety precautions and instructions before installing this product.**
- ALL LIABILITY FOR INSTALLATION AND USE OF THIS PRODUCT RESTS WITH THE OWNER.
- **CARELESS INSTALLATION AND OPERATION CAN RESULT IN SERIOUS INJURY OR EQUIPMENT DAMAGE.**

Injury Hazard

Failure to observe these instructions could lead to severe injury or death.

- Always** remove jewelry and wear eye protection.
- Always** use extreme caution when jacking up a vehicle for work. Set emergency brake and use tire blocks. Locate and use the vehicle manufacturers designated lifting points. Use jack stands.
- Always** use appropriate and adequate care in lifting components into place.
- Always** insure components will remain secure during installation and operation.
- Always** wear safety glasses when installing this kit.
- Always** use extreme caution when drilling on a vehicle. Thoroughly inspect the area to be drilled (on both sides of material) prior to drilling, and relocate any objects that may be damaged.
- Always** use extreme caution when cutting and trimming during fitting.
- Always** tighten all nuts and bolts securely per the installation instructions.
- Always** route electrical cables carefully. Avoid moving parts, components that become hot and rough or sharp edges.
- Always** insulate and protect all exposed wiring and electrical terminals.
- Always** perform regular inspection and maintenance on mounts and related hardware.

Operating Safety

- NEVER stand on the Winch Mount while the vehicle is in motion.
- Clean mud and debris off of Winch Mount prior to winch operation.

I. Tools Required

1/2" Drive Socket Wrench with 3" Extension, socket set, 1/2" Drive Torque Wrench and a wrench set.

II. Kit Contents

QTY	DESCRIPTION	FAB FOURS PART NUMBER
x 1	Winch Mount	N1750-W
x 2	Tow Hook	
x 1	N1750 Hardware Kit	N1750-HW
x 1	N1750 Nissan Titan Instruction Manual	N1750-IM

III. Included Hardware

ITEM NO.	PART NUMBER	DESCRIPTION	N1750-MC/QTY
1	N1750-W	N1750 WINCH MOUNT WELDMENT	1
2	StandardTowHook	STANDARD TOW HOOK	2
3	Preferred Wide FW 0.5	1/2" FLAT WASHER, ZINC	8
4	Regular LW 0.5	1/2" LOCK WASHER, ZINC	4
5	HNUT 0.5000-13-D-N	1/2"-13 HEX NUT, Gr.8, ZINC	4
6	HBOLT 0.5000-13x2x1.25-N	1/2"-13 x 2" HEX BOLT, Gr.8, ZINC	4

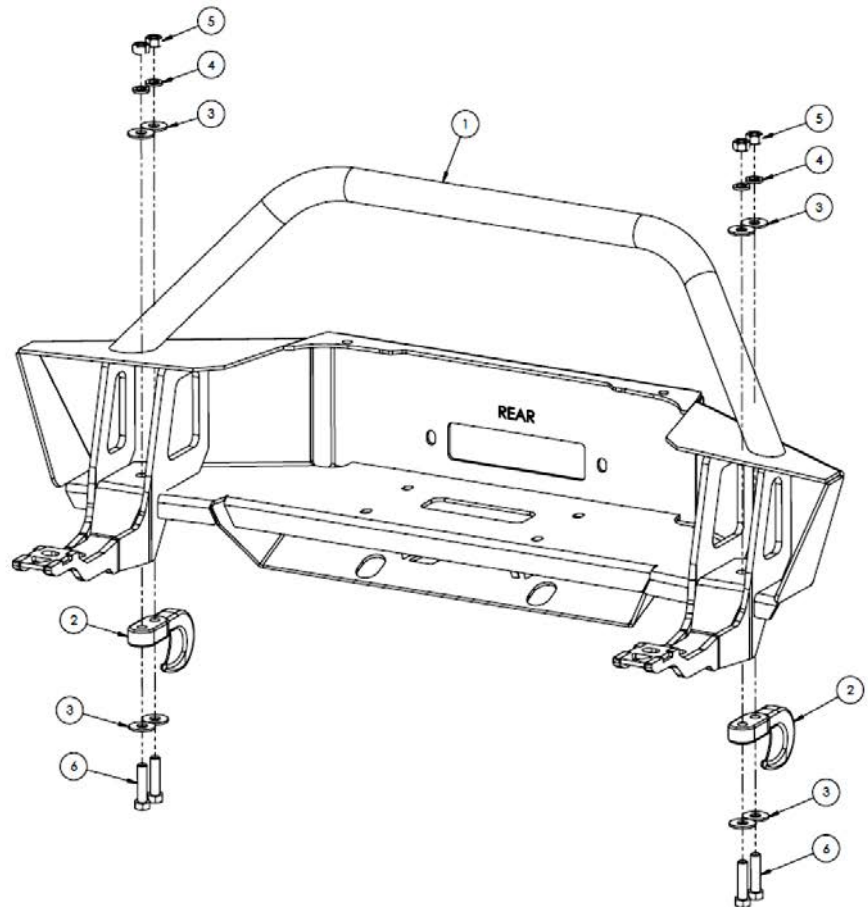

IV. Removal of OEM tow hooks

1. Remove the four (4) 10mm bolts holding the factory skid plate to the bottom of the vehicle and set aside.
2. From underneath the driver side of the vehicle, remove the driver side OEM tow hook using a socket wrench.
 - a) The OEM tow hooks are mounted using two (2) 17mm bolts from underneath.
 - b) Remove the bolts from underneath the vehicle
 - c) Remove the tow hook from the vehicle, setting the OEM fasteners aside for reuse.
3. Repeat the previous step to remove the passenger side OEM tow hook.

NOTE: The bolts that supported the OEM tow hooks will be reused.

V. Installation of Fab Fours Winch Mount

1. Review the exploded parts view above
2. Install the two Tow hooks onto the winch mount using the hardware provided.
3. Torque the Tow Hook Mounting bolts to 106 Foot-Pounds.
4. Install the small frame winch (Customer Supplied).
5. With the aid of a lifting device or additional helpers, lift the winch mount and position it so that the mounts align with the holes in the factory bumper.
6. Carefully slide the Winch mount through the factory bumper.
7. Install the OEM tow hook hardware through the bottom of the winch mount holes.
8. Torque all bolts to 106 Foot-Pounds.
9. Replace the OEM skid plate in the reverse order in which it was removed.