



**INSTALLATION MANUAL**  
**GLADIATOR OVERLANDING RACK EXTENSION**  
**PRODUCT NUMBER: JTOR-02**  
**APPLICATION: 2020 JEEP GLADIATOR**



## **IMPORTANT SAFETY GUIDE** | Your safety and the safety of others is very important.

In order to help you make informed decisions about safety, we have provided the following warnings, safety precautions, installation instructions, and other important information to alert you to potential hazards that could hurt you or others.

Please do a job safety analysis before each task to identify potential hazards for your situation and remove/protect against them. Use own good judgment and take your time.

Check packaged materials immediately upon arrival to ensure that all listed parts are included and undamaged.

**Read and understand all warnings, safety precautions, and instructions before installing this product.**

SENSORS FIELD OF VIEW MAY BE ALTERED WITH USE OF THE REPLACEMENT BUMPER.

---

### **WARNINGS**

- Failure to observe the following warnings and instructions provided in this manual could lead to severe injury and/or death.
- For professional installation only. Careless installation and/or operation can result in serious injury, death, and/or equipment damage. All liability for installation and use rests with the user or consumer.
- Fab Fours, Inc. only approves installing this product according to these written instructions with the hardware provided. Failure to install according to these instructions will invalidate the warranty. This includes, but is not limited to, using alternative installation methods, hardware, or materials.
- This product is for off road use only.

---

### **SAFETY PRECAUTIONS**

- Always remove jewelry and wear eye protection.
- Always use extreme caution when jacking up a vehicle for work. Set emergency brake and use tire blocks. Locate and use the vehicle manufacturers designated lifting points. Use jack stands.
- Always use appropriate and adequate care in lifting components into place.
- Always ensure components will remain secure during installation and operation.
- Always wear safety glasses when installing this kit. A drilling operation will cause flying metal chips. Flying chips can cause serious eye injury.
- Always use extreme caution when drilling a vehicle. Always disconnect power before welding. Thoroughly inspect the area to be drilled (on both sides of material when possible) prior to drilling, and relocate any objects that may be damaged.
- Always use extreme caution when welding a vehicle. Thoroughly inspect the area to be welded (on both sides of material when possible) prior to welding, and relocate any objects that may be a fire hazard. When welding in a cab, make sure the interior surfaces are covered (e.g., welding blanket) and a fire extinguisher is at hand.
- Always use extreme caution when cutting and trimming during fitting.
- Always tighten all nuts and bolts securely per installation instructions.
- Always route electrical cables carefully. Avoid moving parts, components that become hot, and rough or sharp edges.
- Always insulate and protect all exposed wiring and electrical terminals.
- Perform regular inspections and maintenance on mounts and hardware.



# TABLE OF CONTENTS

- 2 SAFETY / DISCLAIMER
- 3 TABLE OF CONTENTS
- 4 A MESSAGE FROM THE OWNER
- 5 GETTING STARTED
- 6 PROVIDED MATERIAL
- 8 INSTALLATION

# A MESSAGE FROM THE OWNER

---



Fab Fours' was born out of a passion for customizing vehicles and a love of the outdoors. Our engineering team uses the latest 3D design software to turn new product ideas into reality. In our factory, designs come to life with the combination of cutting edge technology for metal cutting and forming and an American workforce that puts its' heart and pride into every product.

From design and manufacturing, to quality and delivery, Fab Fours' mission is to be the market leader for steel truck and jeep accessories. We make sure a quality product is delivered on time, more than expected, better than expected to our customers.

Enjoy your new Fab Fours product. Welcome to the family!

*Ereg Higgs*

**FOUNDER, FAB FOURS**

# GETTING STARTED

---

Before you begin the installation process of your new Fab Fours product, we suggest laying out all materials and parts on a pad or protective surface.

Failure to fully account for all components before beginning installation may leave vehicle immobile until part is acquired. Refer to the next pages as an inventory check.

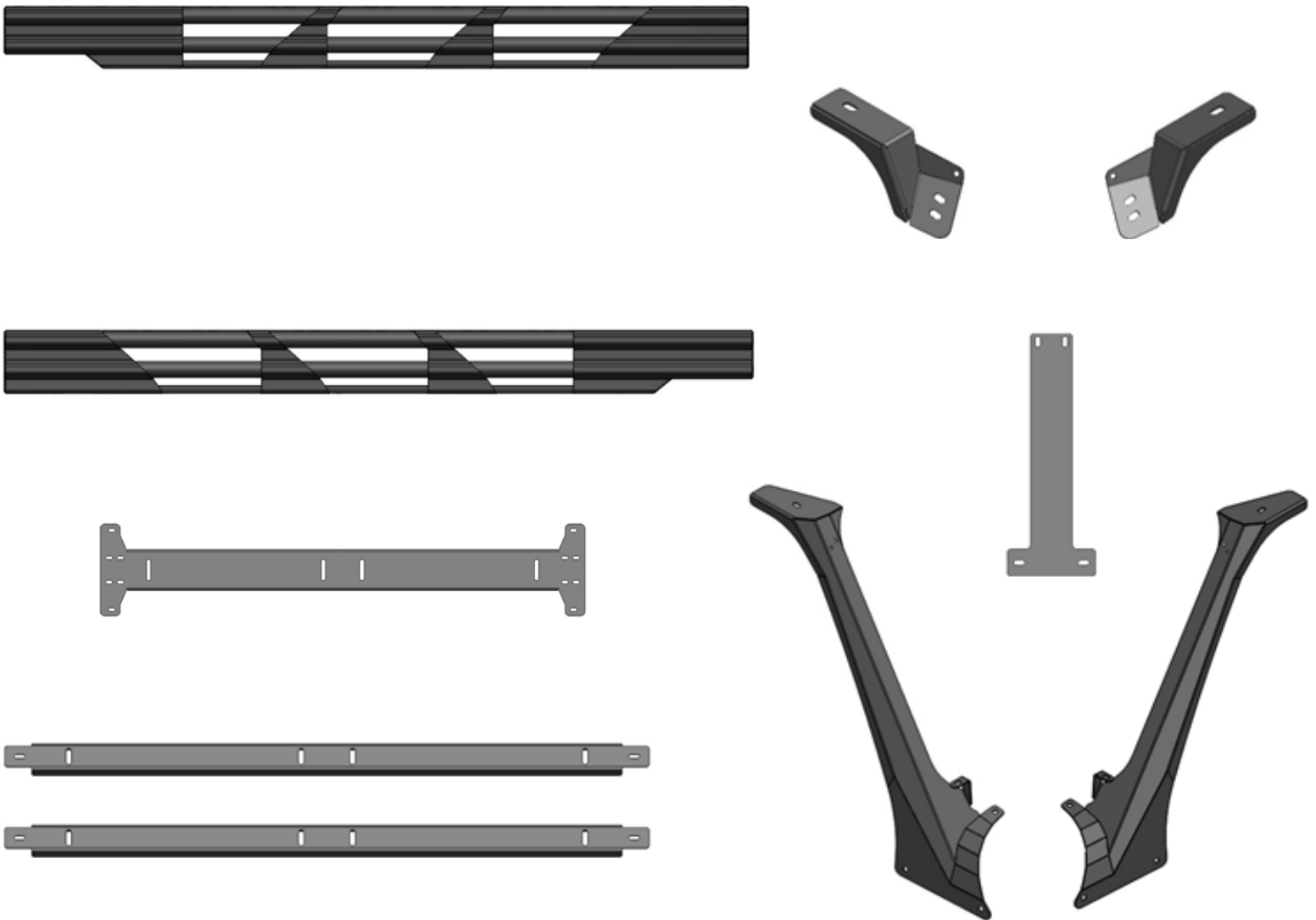

# PROVIDED MATERIALS



Foam Seal

61724 x2

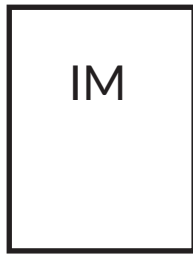

IM

JTOR-02 IM



HW KIT

50211-HW



22075



22076



22077



21950 x2



22081



22080

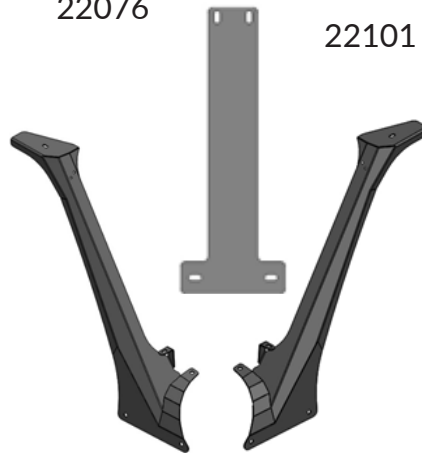

22079

22078

22101

## HARDWARE KIT | 50211

FAB FOURS IDENTIFICATION	COMPONENT DESCRIPTION	QTY
50211-HW	M6 x 1.0 x 50mm Button Head Cap Screw, Stainless Steel	2
50211-HW	M6 Lock Washer, Stainless Steel	2
50211-HW	M8 x 1.25 x 35mm Button Head Cap Screw, Stainless Steel	4
50211-HW	M8 Lock Washer, Stainless Steel	4
50211-HW	1/2" Tall Spacer, Aluminum	2
50211-HW	1/4" Tall Spacer, Aluminum	4
502110-HW	3/4" x 9/16" Adhesive Rubber Bumper	4
502110-HW	5/16"-18 Yellow Zinc Hex Head Bolt, Grade 8	4
50211-HW	5/16" Yellow Zinc Hex Nut, Grade 8	4
50211-HW	5/16" Yellow Zinc Flat Washer, Grade 8	8
50211-HW	5/16" Yellow Zinc Lock Washer, Grade 8	4
50211-HW	5/16"-18 Hex Head Bolt, Stainless Steel	20
50211-HW	5/16" Hex Nut, Stainless Steel	20

## TOOLS REQUIRED

- 1/2" socket wrench
- 9/16" socket wrench
- 5/32" allen wrench
- 3/16" allen wrench
- T40 star-tip socket

## ASSISTANCE

We recommend two people perform the installation as items are heavy and may need to be held in place while installing.

## ORGANIZATION

Disassemble the vehicle where you can catalog and store everything. We suggest labeling and bagging all the OEM bolts when removing from the vehicle. Failure to keep track of parts could lead to an inability to properly reinstall components.

# HARDWARE KIT | 50211

FAB FOURS IDENTIFICATION	COMPONENT DESCRIPTION	QTY
50211-HW	5/16" Flat Washers, Stainless Steel	46
50211-HW	5/16" Lock Washer, Stainless Steel	20
50211-HW	3/8"-16 Yellow Zinc Hex Head Bolt, Grade 8	6
50211-HW	3/8" Yellow Zinc Hex Nut, Grade 8	6
50211-HW	3/8" Yellow Zinc Flat Washer, Grade 8	12
50211-HW	3/8" Yellow Zinc Lock Washer, Grade 8	6
502110-HW	#8-32 Button Head Bolt, Stainless Steel	4
502110-HW	#8 Nylock Hex Nut, Stainless Steel	4
50211-HW	#8 Flat Washer, Stainless Steel	8

# INSTALLATION

*NOTE: If assembling the JTOR-01 and JTOR-02 at the same time: Follow Step 1-3 from the JTOR-01 Instruction Manual. If JTOR-01 is already installed: remove the cross bars and tube assemblies from the lower mounting structure.\*\*\**

**1. Place with the JTOR-02 tube assemblies (22075-22076) on top of the bed rail mounting assemblies and use three (3) 5/16" button head bolts with flat/lock washers and nuts to attach them with a 1/2" socket wrench. Repeat on opposite side. (Use hardware from the JTOR-01 kit 50190-HW). Figure 1.**

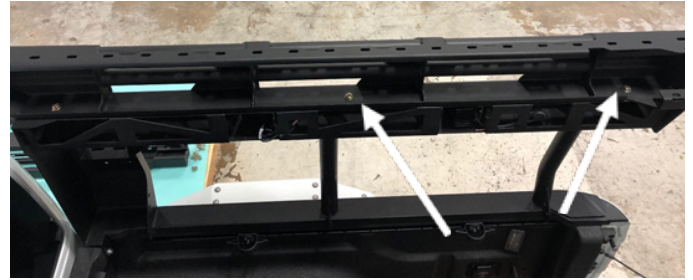

Figure 1

**2. Use a 5/16" yellow zinc hex head bolt, flat/lock washers and nuts in the back of the tube assemblies (50211-HW). Figure 2**

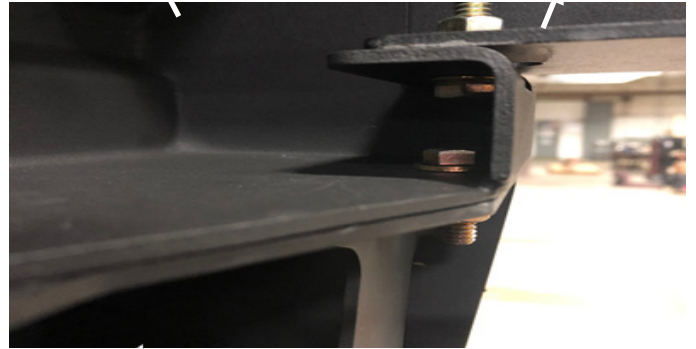

Figure 2

**3. Loosely install the center cross bar (22077) using six (6) 5/16" stainless steel button head bolt, flat/lock washer, and nuts with a 3/16" allen and 1/2" socket wrench (50211-HW). Do not tighten the bolts at this time. Figure 3.**



Figure 3



4. If you have or are going to install a Vicowl onto your Gladiator skip steps 4-8 and install the mounting arms (22080-22081) to the vicowl using the #8 stainless steel hardware (50211-HW) Figure 4.



Figure 4

5. Use a T40 star-tip socket to remove three (3) bolts on the cowl cover. Repeat on opposite side. Figure 5.

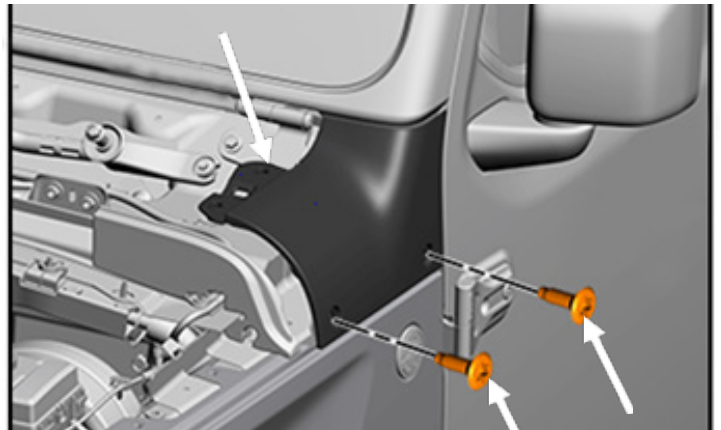

Figure 5

6. Place the 1/2" aluminum spacer in the upper bolt hole while placing two (2) 1/4" aluminum spacers in the lower bolt holes (50211-HW). Figure 6.

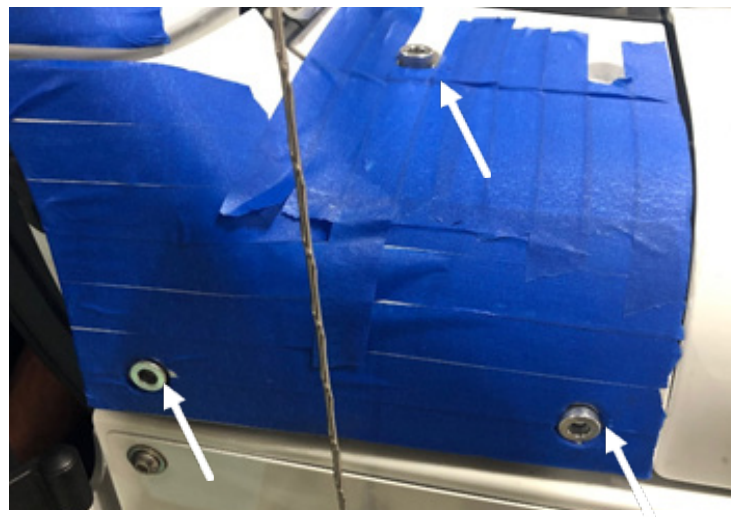

Figure 6

7. Take the two support arms (22078-22079) and place two (2) rubber bumpers on the top section (50211-HW). Figure 7.

8. Cut the foam tape to fit along the support arm profiles. Figure 7.



Figure 7

9. Place the support arm into place and use a 6M button head bolt with lock washer and 5/16" flat washers on top and two (2) 8M button head bolts with lock washers and 5/16" flat washers on the bottom. Fully tighten all the bolts with a 5/32 socket wrench. Repeat on opposite side. Figure 8.

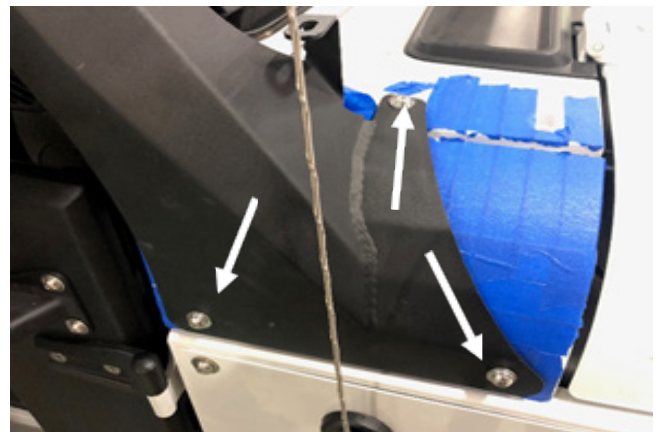

Figure 8

10. Place the front tube assembly from the JTOR-01 on the front support arm and loosely attach it to the rear tube assembly using three (3) 3/8" yellow zinc hex head bolts with flat/lock washers and nuts (50211-HW). Figure 9-10.

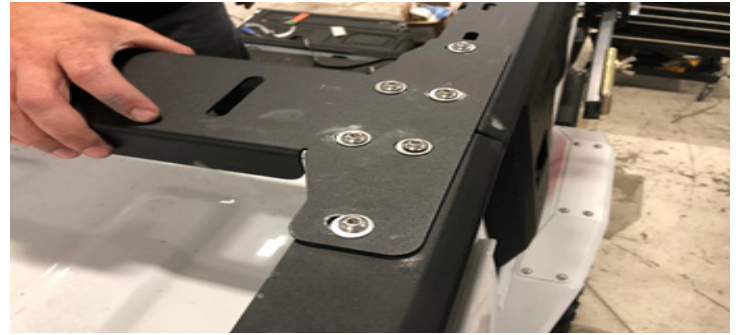

Figure 9



Figure 10

**11. Loosely install the remaining six (6) stainless steel button head bolts in the center crossbar to the front tube assembly using a 3/16" allen wrench and 1/2" socket wrench (50211-HW). Align the tube assemblies so that all faces are flush, then use a 9/16" socket wrench to fully tighten the 3/8" hardware installed in step 8. Repeat on opposite side. Figure 11.**



*Figure 11*

**12. Use a 1/2" socket wrench to attach the tube assembly to the front support arms using a 5/16" yellow zinc hex head bolt with flat/lock washers and nuts (50211-HW). Figure 12.**



*Figure 12*

**13. Loosely install the front visor using six (6) 5/16" button head bolts with flat/lock washers and nuts from the JTOR-01 hardware kit using a 3/16" allen wrench and 1/2" socket wrench (50190-HW). Figure 13.**

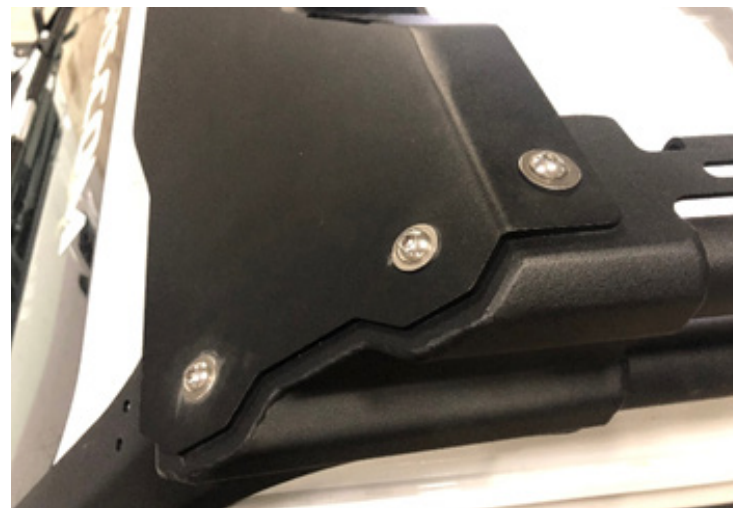

*Figure 13*



14. Loosely install the back-cross bar using four (4) 5/16" button head bolts with flat/lock washers and nuts from the JTOR-01 hardware kit using a 3/16" allen wrench and 1/2" socket wrench (50190-HW). Use two (2) yellow zinc hex head bolts with flat/lock washers and nuts on the lower section of the back-cross bar. Figure 14-15.



Figure 14

15. Use the remaining 5/16" stainless steel hardware to install the four (4) crossbars as desired. Figure 16.



Figure 15

16. When installing the crossbar closest to the visor: install the visor support (22101) between the visor and the cross bar using the four (4) 5/16 stainless steel bolts, flat/lock washers and nuts with a 3/16" Allen wrench and 1/2 socket wrench (50211-HW). Figure 17.

16. With all cross bars and assemblies installed and in the desired position, fully tighten down all mounting hardware to secure the rack in place.

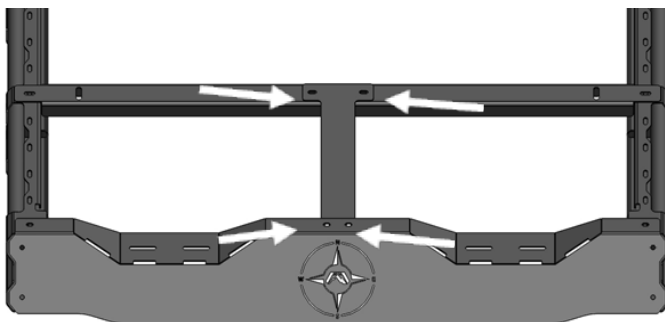

Figure 17



Figure 16