



# Installation Instructions

## GMC 1500 Premium Front Bumper

Product Number: H3150, H3151, H3152 Application: '14  
GMC 1500

## SAFETY

### Your safety and the safety of others is very important.

- In order to help you make informed decisions about safety, we have provided installation instructions and other information.
- These instructions alert you to potential hazards that could hurt you or others.
- Please do a job safety analysis (JSA) before each task to identify potential hazards for your situation and remove/protect against them.
- You must use your own good judgment, and take your time.

Read and understand all safety precautions and instructions before installing this product.

**THIS PRODUCT IS FOR OFFROAD USE ONLY. ALL LIABILITY FOR INSTALLATION AND USE RESTS WITH THE OWNER.**

**CARELESS INSTALLATION AND OPERATION CAN RESULT IN SERIOUS INJURY OR EQUIPMENT DAMAGE.**

## Injury hazard

### Failure to observe these instructions could lead to severe injury or death.

- Always remove jewelry and wear eye protection.
- Always use extreme caution when jacking up a vehicle for work. Set emergency brake and use tire blocks. Locate and use the vehicle manufacturers designated lifting points. Use jack stands.
- Always use appropriate and adequate care in lifting components into place.
- Always insure components will remain secure during installation and operation.
- Always wear safety glasses when installing this kit. A drilling operation will cause flying metal chips. Flying chips can cause serious eye injury.
- Always use extreme caution when drilling on a vehicle. Thoroughly inspect the area to be drilled (on both sides of material) prior to drilling, and relocate any objects that may be damaged.
- Always use extreme caution when cutting and trimming during fitting.
- Always tighten all nuts and bolts securely per installation instructions.
- Always route electrical cables carefully. Avoid moving parts, components that become hot and rough or sharp edges.
- Always insulate and protect all exposed wiring and electrical terminals.
- Always perform regular inspections and maintenance on mounts and related hardware.





# Installation Instructions

## GMC 1500 Premium Front Bumper

Product Number: H3150, H3151, H3152  
Application: '14 GMC 1500

### I. Overview

Congratulations on your new purchase of the industries' best and most stylish Front Bumper available for the 2014 GMC 1500! This Bumper has been engineered for strength while keeping the weight down.

Your Front Bumper designed in 3-D from digitized data, CNC laser cut, fabricated, and powder coated... all in the U.S.A.

Enjoy the fit and finish of a quality GMC 1500 Front Bumper from Fab Fours Inc.

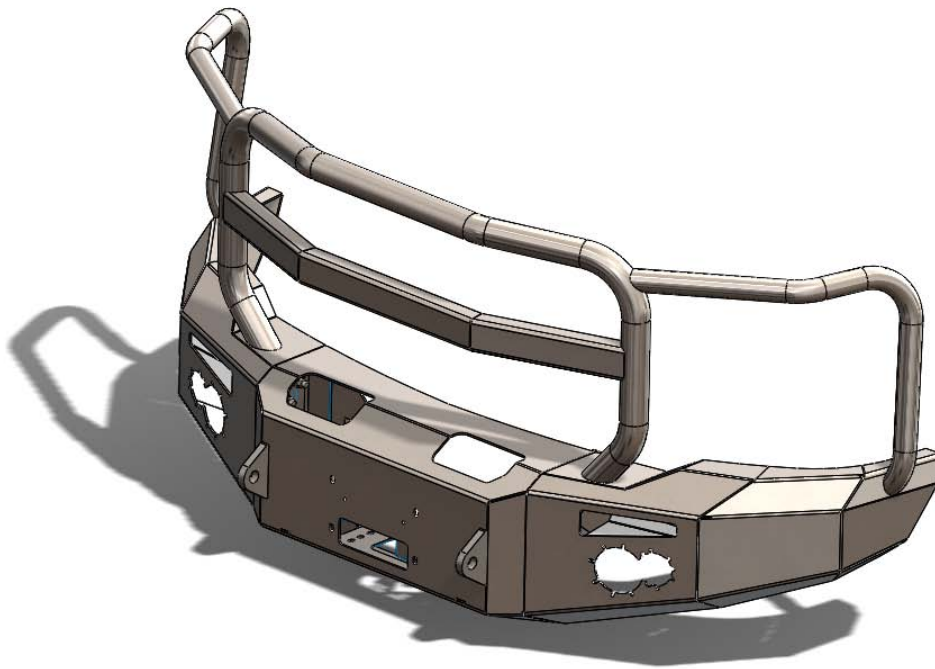



# Installation Instructions

## GMC 1500 Premium Front Bumper

Product Number: H3150, H3151, H3152  
Application: '14 GMC 1500

### Parts List

- W315X replacement bumper
- W315X-HW fastener kit
- HDLA-HW
- 4 Stud Plates
- Light Kitting [i.e. 20090(2), 61349(2), 61350(2)]
- Instruction Manual

### Tools Required

- Socket Wrench with Extension (Ratcheting wrenches may also be convenient)
- 7mm , 15mm , & 18mm Sockets and Box End Wrenches
- T15 torx
- Flat Head Screw Drivers
- Floor Jack and wood block.

## II. Removal of OEM Bumper

**Note: Save all OEM parts until installation is complete!**

- A. Open hood and locate push pins on radiator cover. Using a flat head screw driver, pull the head of the push pins up, remove push pin and lift radiator cover off. This will allow access to top Grille bolts (Ref. Figure 1).



Figure 1





# Installation Instructions

## GMC 1500 Premium Front Bumper

Product Number: H3150, H3151, H3152  
Application: '14 GMC 1500

- B. Remove the valence from the vehicle. Unfasten the screws located in the forward section of each wheel well connecting the wheel well liner and the trim to the vehicle (Ref. 2a). Carefully pull both the trim and liner away from the vehicle, this will grant access to the interior cavity (Ref. 2b).**



Figure 2a



Figure 2b

- C. At this point the corner of the valence may still be held in place by the black “backing support” secured to the frame by hex head screws, use a 7mm short socket or ratchet wrench to unscrew. The color coded arrows show the location and direction of screws (Ref. 2c-d). Corners of valence should easily pull away. Locate retaining clips at bottom of valence. Depress clips and begin to remove valence as each clip is released.**

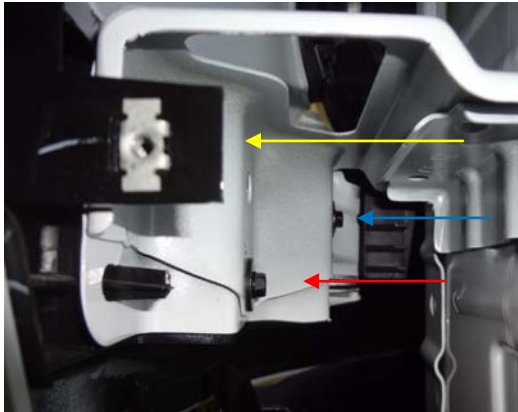

Figure 2c

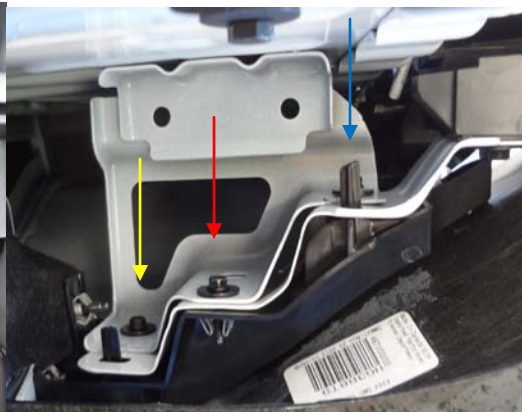

Figure 2d





# Installation Instructions

## GMC 1500 Premium Front Bumper

Product Number: H3150, H3151, H3152  
Application: '14 GMC 1500

D. Disconnect electrical harness from vehicle.



Figure 3(electrical harness disconnected)

E. Remove the fasteners connecting the grille to the frame. Eight bolts, indicated by the red ovals, are located at the top and bottom of the grille and two bolts are located behind the grill.



Figure 4a



Figure 4b





# Installation Instructions

## GMC 1500 Premium Front Bumper

Product Number: H3150, H3151, H3152  
Application: '14 GMC 1500



Figure 4c



Figure 4d

- F. Remove the fasteners connecting the Bumper to the frame. Using a socket/wrench remove bolts from the top and bottom of bracket connected to the bumper. Pull bumper away from vehicle and remove forward facing bolts holding bracket to frame. Repeat process on each side of vehicle.



Figure 5





# Installation Instructions

## GMC 1500 Premium Front Bumper

Product Number: H3150, H3151, H3152  
Application: '14 GMC 1500

- G. Remove bolts securing tow hooks to frame. Location is indicated in image below by green rectangle (Ref. 6b).



Figure 6a

Figure 6b

- H. Replace valence and grille by reversing the order of Removal steps A through E
- I. Remove OEM electrical harness from bumper. Disconnect harness from fog lights and sensors. Pop out plastic clips holding harness to bumper on both sides and carefully pull away.

### III. Pre-Installation

**NOTE: The Following Installation steps apply to the installation of the Front Bumper. PLEASE READ THE ENTIRE MANUAL BEFORE ATEMPTING INSTALLATION! Ignoring these steps will increase your probability of scratching the vehicle during product Installation!**





# Installation Instructions

## GMC 1500 Premium Front Bumper

Product Number: H3150, H3151, H3152  
Application: '14 GMC 1500

- A. Remove the Bumper from the shipping carton. Lay all items out on a blanket to prevent damage to the powder coating.
- B. Tap into OEM electrical harness and wiring using supplied tap connectors. All wiring is easily accessible with the exception of the RH turn signal wiring. Accessing passenger side (i.e. RH) turn signal wiring will require the removal of the "air box" (Ref. Figure W-TS-1). Once the "air box" is removed, the wires to be spliced will be located under the signal box (Ref. Figure W-TS-2). It is strongly recommended a multimeter, or its equivalent is used to confirm wiring before splicing.

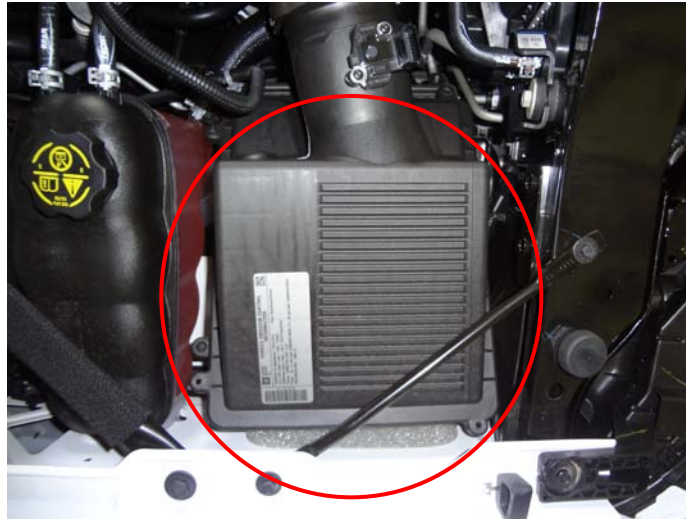

*Figure W-TS-1*



*Figure W-TS-2*







# Installation Instructions

## GMC 1500 Premium Front Bumper

Product Number: H3150, H3151, H3152  
Application: '14 GMC 1500

C. Connect supplied wiring harness to tap connectors. **DO NOT CONNECT LIGHTS UNTIL BUMPER IS INSTALLED.**

### WIRE COLORS:

<u>WIRE</u>	<u>FAB FOURS</u>	<u>OEM COLOR</u>
<div style="border: 1px solid black; padding: 5px; display: inline-block;">TURN SIGNALS (Ref. Figure W-TS-3, 4)</div> Turn	Green	Blue (LH) Green(RH)
	White	Yellow
Ground	Red	Black
	Green	Brown
<div style="border: 1px solid black; padding: 5px; display: inline-block;">FOG LIGHT (Ref. Figure W-FL-1, 2)</div> Power Ground	Red	Black



Figure W-TS-3



Figure W-TS-4





# Installation Instructions

## GMC 1500 Premium Front Bumper

Product Number: H3150, H3151, H3152  
Application: '14 GMC 1500



Figure W-FL-1



Figure W-FL-2

- D. Install turn indicators into the plastic light insert using three self-tapping screws as shown below:**

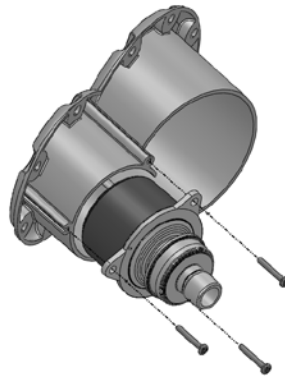

Figure 6

- E. Install the light inserts with turn indicators into the cutout in the bumper. Use the  $\frac{3}{4}$ " length  $\frac{1}{4}$ " stainless steel button head,  $\frac{1}{4}$ " washers and hex nuts to fasten the insert through the holes shown below:**





# Installation Instructions

## GMC 1500 Premium Front Bumper

Product Number: H3150, H3151, H3152  
Application: '14 GMC 1500

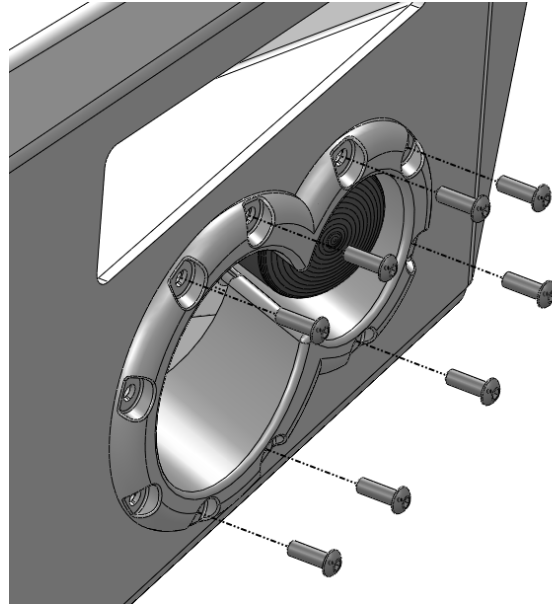

Figure 7

- F. Install the Fab Fours fog lights onto the mounting brackets as shown below using the #8 button head screws, washers, and hex nuts.

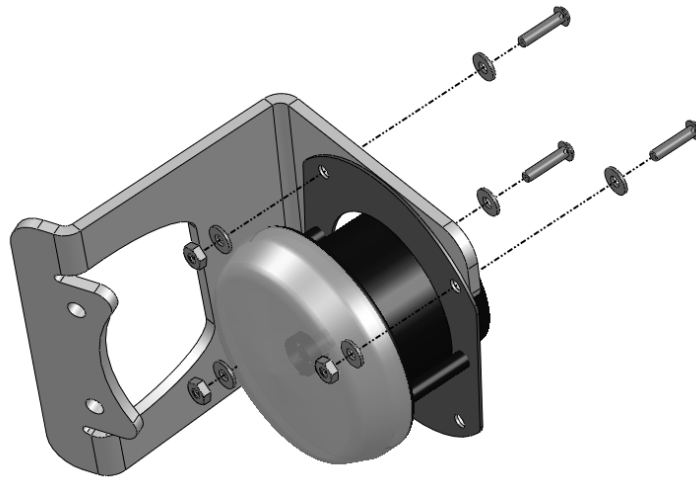

Figure 8

- G. Install the fog light and bracket into the bumper using the remaining two holes available in the light insert. Use the 1-1/2" length 1/4" stainless steel button heads with 1/4" washers and nuts.





# Installation Instructions

## GMC 1500 Premium Front Bumper

Product Number: H3150, H3151, H3152  
Application: '14 GMC 1500

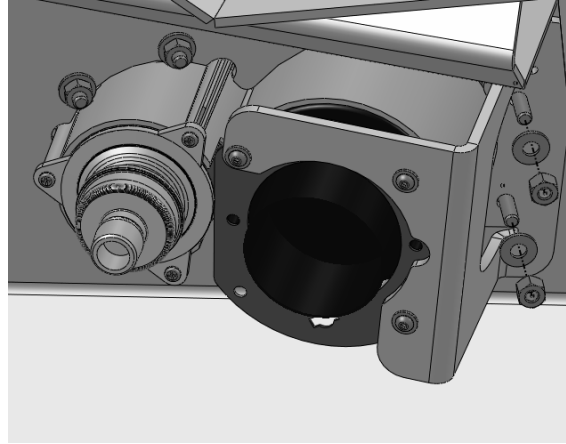

Figure 9

- H. Secure OEM electrical harness to the Fab Fours bumper.
- I. Repeat steps A through G for other side.
- **Optional:** If installing winch and roller fairlead into bumper, do it at this time. Follow the winch manufacturer's instructions for installation. If you are installing a winch with a pulling capacity of 12,000 lbs., the front face mounting holes must be used.

If not installing a winch, a license plate may be installed onto the front face of the bumper.

#### IV. Front Bumper Installation

- A. Mount bracket to truck frame. Three bolts pass through the front of the frame and are indicated by the red boxes. One bolt passes through the side of the frame (i.e. cross bolt) and is indicated by the blue circles (Ref. 10a-b). All bolts should be hand tight to allow for adjustment.





# Installation Instructions

## GMC 1500 Premium Front Bumper

Product Number: H3150, H3151, H3152  
Application: '14 GMC 1500



Figure 10a



Figure 10b

- B. Mount bracket to bumper. With the help of at least two others, and possibly a floor jack, to support the center of the bumper, lift the Fab Fours bumper into place (Ref 11a-b). Do Not Fully Tighten, Hand Tighten Only!**

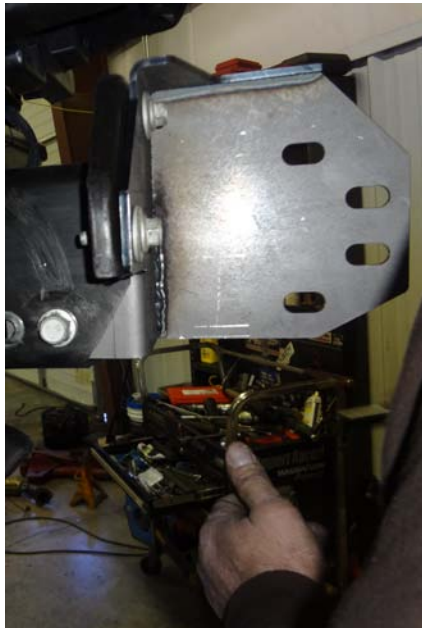

Figure 11a



Figure 11b





# Installation Instructions

## GMC 1500 Premium Front Bumper

Product Number: H3150, H3151, H3152  
Application: '14 GMC 1500

- C. Insert the set of stud plates from the inside facing out and tighten. Do Not Fully Tighten, Hand Tighten Only!



Figure 12

- D. Align the bumper side to side and top to bottom to ensure a perfect fit to the truck. Allow 0.375" of clearance to all painted surfaces if possible. This is to allow for frame flex!
- E. Fully tighten all fasteners between bumper and brackets as well as brackets and frame.

**Note: Do Not Over Tighten "Cross Bolt". Frame Should Not Compress!**

- F. The fog light wiring may be installed at this time. To do so, connect wiring to fog light and tap into OEM fog light wiring using supplied tap connectors. Secure excess wiring to bumper.
- G. The turn indicator wiring may be installed at this time. To do so, connect wiring to turn indicator and tap into OEM turn indicator wiring using supplied tap connectors.
- H. Enjoy your New Rear Replacement Bumper from Fab Fours!





# Installation Instructions

## GMC 1500 Premium Front Bumper

Product Number: H3150, H3151, H3152  
Application: '14 GMC 1500

### *Maintenance/Care*

- Periodically check and tighten all fasteners.
- Stripped, fractured, or bent bolts or nuts need to be replaced.
- After washing of the vehicle make sure to fully dry all surfaces



More than expected... Better than expected

