



Installation Instructions

Ford Replacement Bumper

Product Number: S2550
Application: '11-Current Ford Super Duty

SAFETY

Your safety and the safety of others is very important.

- In order to help you make informed decisions about safety, we have provided installation instructions and other information.
- These instructions alert you to potential hazards that could hurt you or others.
- Please do a job safety analysis (JSA) before each task to identify potential hazards for your situation and remove/protect against them.
- You must use your own good judgment, and take your time.

Read and understand all safety precautions and instructions before installing this product.

THIS PRODUCT IS FOR OFFROAD USE ONLY. ALL LIABILITY FOR INSTALLATION AND USE RESTS WITH THE OWNER.

CARELESS INSTALLATION AND OPERATION CAN RESULT IN SERIOUS INJURY OR EQUIPMENT DAMAGE.

Injury hazard

Failure to observe these instructions could lead to severe injury or death.

- Always** remove jewelry and wear eye protection.
- Always** use extreme caution when jacking up a vehicle for work. Set emergency brake and use tire blocks. Locate and use the vehicle manufacturers designated lifting points. Use jack stands.
- Always** use appropriate and adequate care in lifting components into place.
- Always** insure components will remain secure during installation and operation.
- Always** wear safety glasses when installing this kit. A drilling operation will cause flying metal chips. Flying chips can cause serious eye injury.
- Always** use extreme caution when drilling on a vehicle. Thoroughly inspect the area to be drilled (on both sides of material) prior to drilling, and relocate any objects that may be damaged.
- Always** use extreme caution when cutting and trimming during fitting.
- Always** tighten all nuts and bolts securely per installation instructions.
- Always** route electrical cables carefully. Avoid moving parts, components that become hot and rough or sharp edges.
- Always** insulate and protect all exposed wiring and electrical terminals.
- Always** perform regular inspections and maintenance on mounts and related hardware.





Installation Instructions

Ford Replacement Bumper

Product Number: S2550
Application: '11-Current Ford Super Duty

I. Overview

Congratulations on your purchase of the industries' best and most stylish Ford Replacement Bumper! This bumper has been **engineered** for strength while keeping the weight down.

Your bumper was designed in 3-D from digitized data, CNC laser cut, fabricated, and powder coated... all in the U.S.A.

Enjoy the fit and finish of a quality Ford Replacement Bumper from Fab Fours Inc!

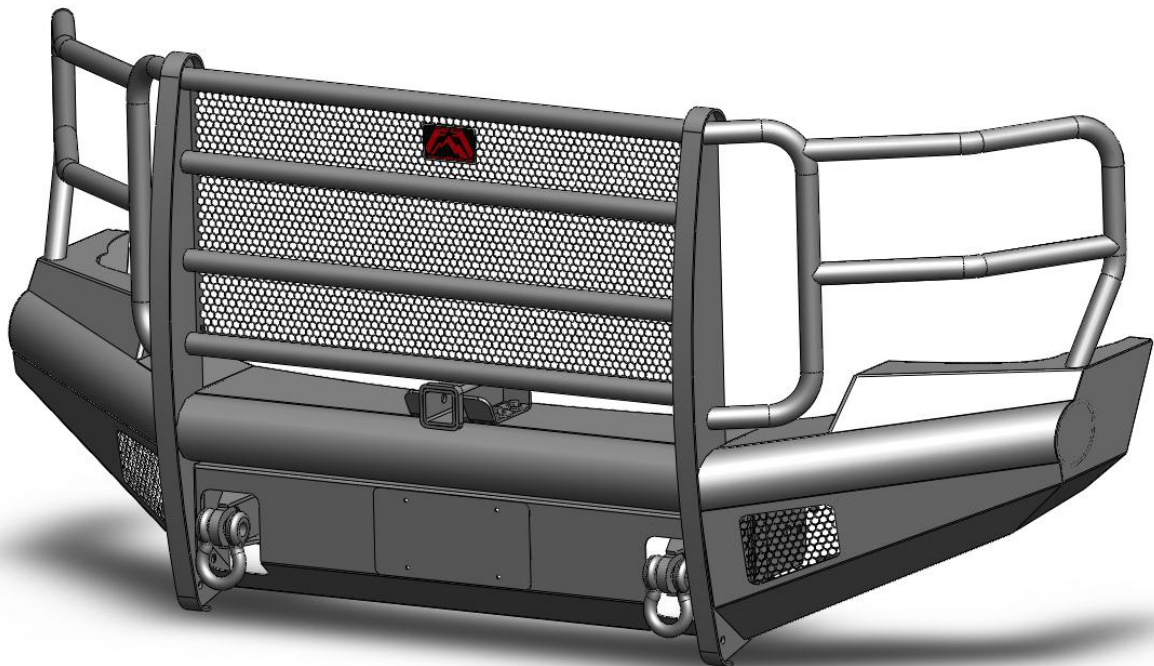

II. Tools Required

- Socket Wrench With Extension
- 5/32" Allen Wrench
- 1/8" Allen Wrench
- 18mm Socket
- 3/4" Socket
- 3/4" Open End Wrench
- 7/16" Open End Wrench
- 3/8" Open End Wrench
- 7/32" Socket
- Phillips Screwdriver

III. Vehicle Preparation

1. Disconnect factory fog lamp harness from the connector on the lower radiator core support.
2. Unclip the splash mat from the factory bumper and fold up out of the way.
3. Remove bumper support bracket screws from the body mount bracket behind the bumper with a 13mm wrench or socket.
4. While supporting the bumper, unscrew the main bumper mounting bolts from the front face of the bumper (Shown Below). The bolts will remain captive in the bumper.

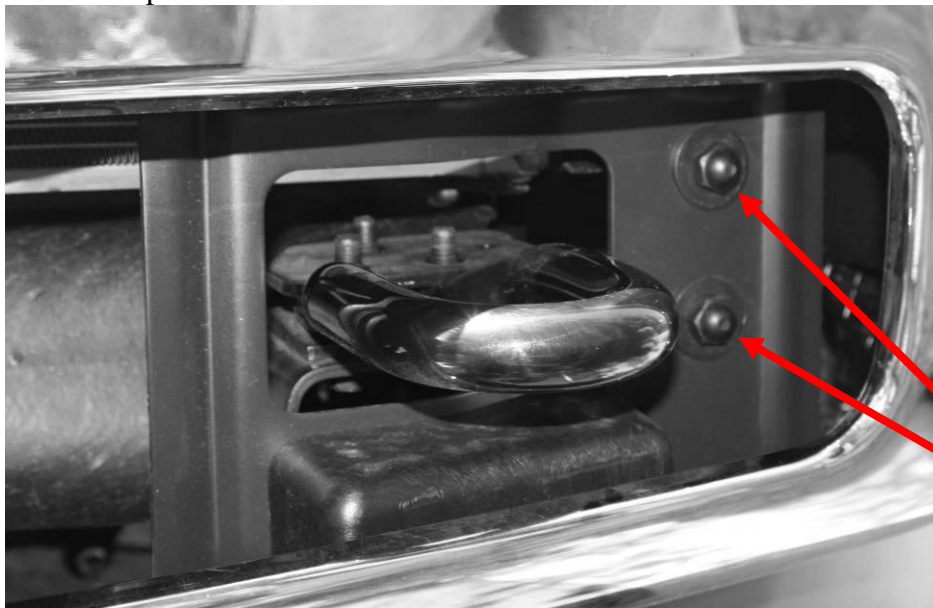

Figure 1 - Bumper Mount Bolts

5. Remove OEM bumper assembly and set aside.
6. Remove the under-run guards from both frame rails with an 18mm Socket. Save this hardware for later use.

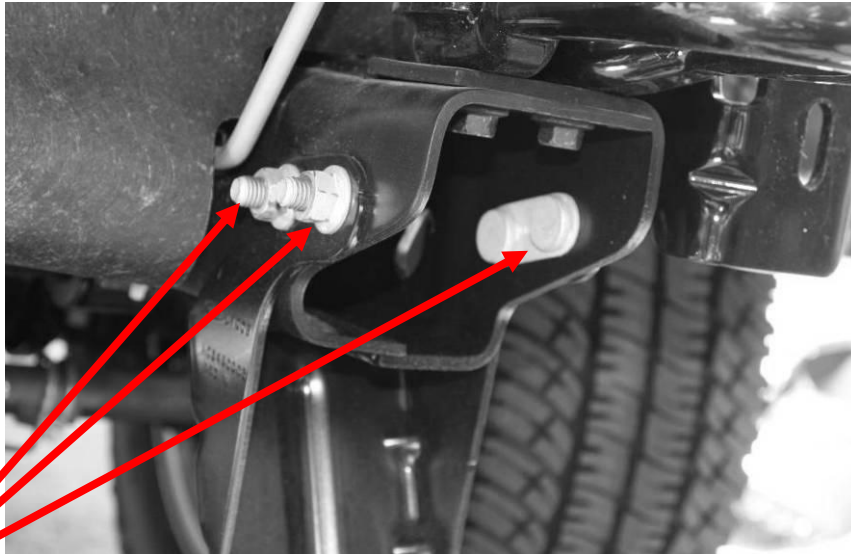

Figure 2 - Under-run Hardware

7. Remove the bumper mount / tow hook assembly from both frame rails using a 15mm socket. Save this hardware for later use.



Figure 3 - Tow Hook Removal

IV. Bumper Installation

NOTE: The Following Installation steps apply to the installation of the Bumper to the vehicle. PLEASE READ THE ENTIRE MANUAL BEFORE ATEMPTING INSTALLATION! Ignoring these steps will increase your probability of scratching the vehicle during product Installation!

1. Remove the Bumper from the shipping carton. Lay all items out on a blanket to prevent damage to the powder coating. Install lower guard (**IF INSTALLING A WINCH SEE WINCH TRAY INSTALLATION INSTRUCTIONS**) by rotating it into position from the bottom of the bumper as shown below. Install three ½" fasteners (Provided in hardware bag labeled 20260-HW) per side with bolt heads facing the inside of the bumper.

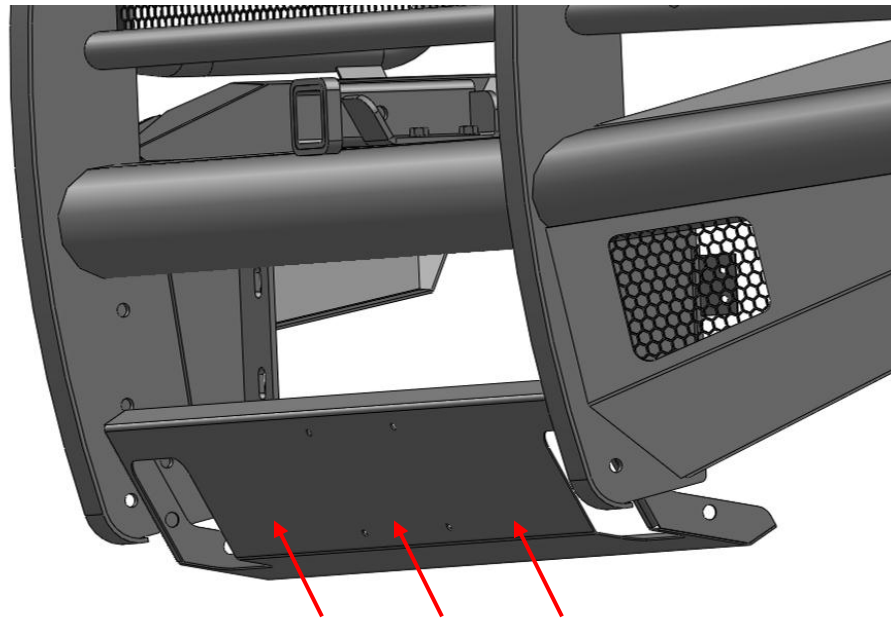

Figure 4 - Lower Guard Installation

2. **OPTIONAL:** If you wish to retain the stock fog lamps, remove the lights from the stock bumper and reinstall using OEM plastic push rivets and adjuster screw in the provided brackets behind the protective mesh.

3. **OPTIONAL:** If installing your bumper with D-ring shackle mounts, they should be placed inside the bumper mounting brackets before final installation. Insert the shackle mounts from the front of the bumper as shown below.

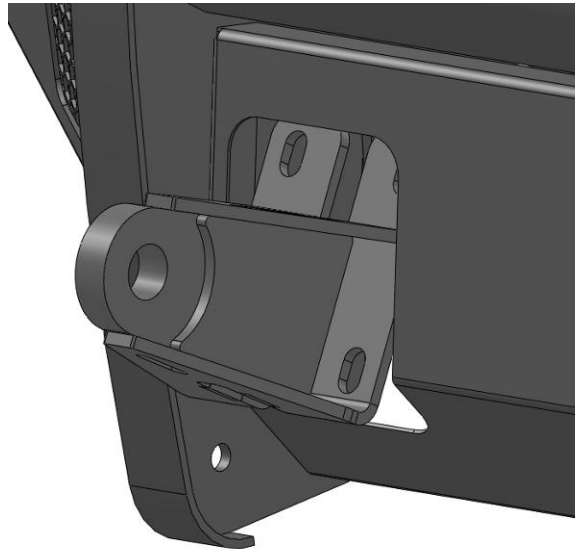

Figure 5 - Shackle Bracket Installation

4. **OPTIONAL:** If installing the 2" receiver hitch accessory, attach it to the bumper with the provided 1/2" hardware

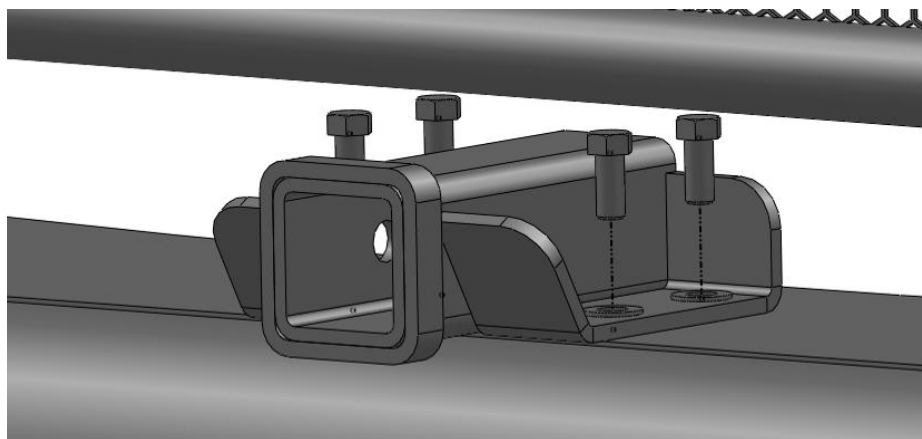

Figure 6 - Hitch Installation

5. Install intermediate brackets in the orientation shown below (larger offset to the outside of the truck) using the OEM mount locations. **DO NOT TIGHTEN UNTIL BUMPER ASSEMBLY HAS BEEN INSTALLED AND ALIGNED.**

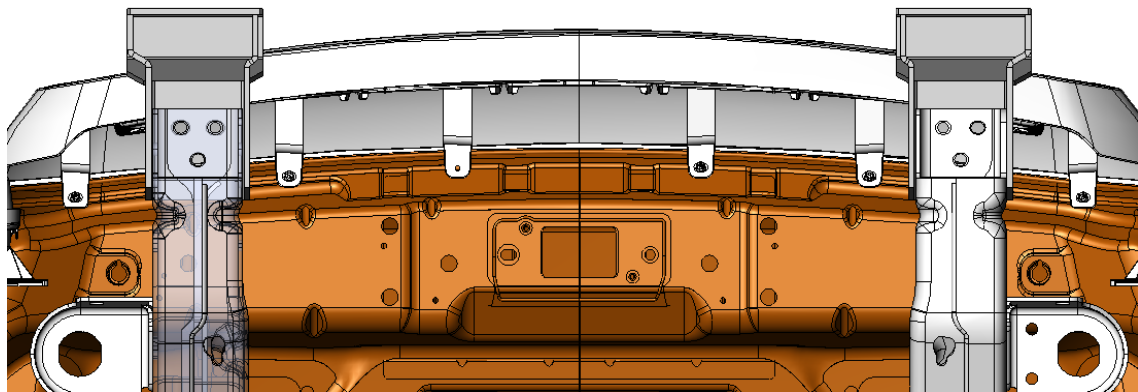

Figure 7 - Intermediate bracket Orientation (View From Below)

6. Lift bumper and align mounting slots with the mating slots on the intermediate mounts. Install ½” mounting bolts but do not tighten fully. It may be helpful to support bumper with a floor jack(s) during install. Repeat for other side
7. Reinstall hood latch lever to provided bracket with OEM fastener.
8. Adjust the bumper to achieve good visual alignment as follows:
 - a. Adjust and up/down and left right alignment with the intermediate mount bolts.
 - b. Tighten all fasteners; beginning with frame mounts. Then tighten all mount-to-bumper fasteners.
9. **OPTIONAL:** Trim inner-fender liners to match bumper if desired.



Installation Instructions Ford Replacement Bumper

Product Number: S2550

Application: '11-Current Ford Super Duty

Install the Supplied Tow Hooks in the orientation shown below (Open to the inside and on the outside of the brace) using the supplied $\frac{1}{2}$ "-13 bolts, washers, and nuts.

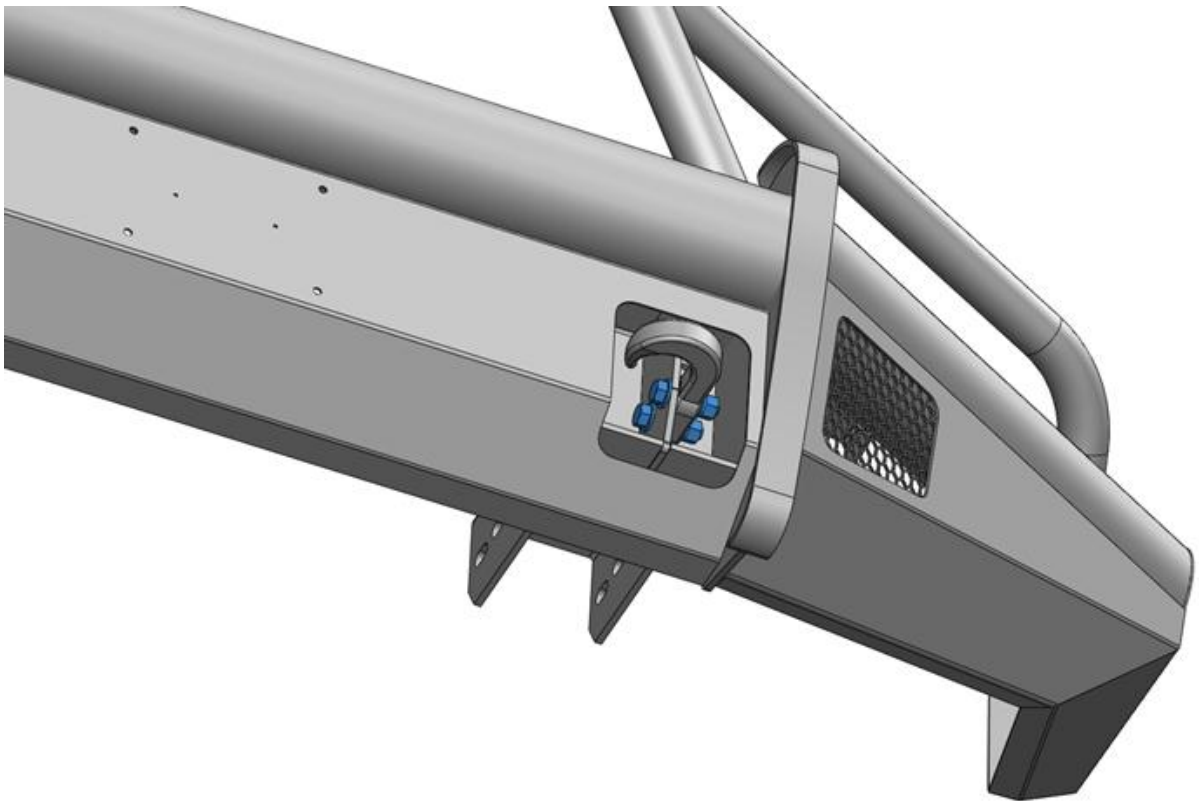



Installation Instructions
Ford Replacement Bumper
Product Number: S2550
Application: '11-Current Ford Super Duty

Maintenance/Care

- Check for loose fasteners after the first 100mi of driving (less for severe duty applications)
- Periodically check and tighten all fasteners.
- Stripped, fractured, or bent bolts or nuts need to be replaced.



More than expected... Better than expected

