



Installation Instructions

Rear Bumper

Product Number: W1350, W1351
Application: '99-Current Super Duty

SAFETY

Your safety and the safety of others is very important.

- In order to help you make informed decisions about safety, we have provided installation instructions and other information.
- These instructions alert you to potential hazards that could hurt you or others.
- Please do a job safety analysis (JSA) before each task to identify potential hazards for your situation and remove/protect against them.
- You must use your own good judgment, and take your time.

Read and understand all safety precautions and instructions before installing this product.

THIS PRODUCT IS FOR OFFROAD USE ONLY. ALL LIABILITY FOR INSTALLATION AND USE RESTS WITH THE OWNER.

CARELESS INSTALLATION AND OPERATION CAN RESULT IN SERIOUS INJURY OR EQUIPMENT DAMAGE.

SENSORS' FIELD OF VIEW WILL BE ALTERED WITH USE OF THE REPLACEMENT BUMPER.

Injury hazard

Failure to observe these instructions could lead to severe injury or death.

- Always** remove jewelry and wear eye protection.
- Always** use extreme caution when jacking up a vehicle for work. Set emergency brake and use tire blocks. Locate and use the vehicle manufacturers designated lifting points. Use jack stands.
- Always** use appropriate and adequate care in lifting components into place.
- Always** insure components will remain secure during installation and operation.
- Always** wear safety glasses when installing this kit. A drilling operation will cause flying metal chips. Flying chips can cause serious eye injury.
- Always** use extreme caution when drilling on a vehicle. Thoroughly inspect the area to be drilled (on both sides of material) prior to drilling, and relocate any objects that may be damaged.
- Always** use extreme caution when cutting and trimming during fitting.
- Always** tighten all nuts and bolts securely per installation instructions.
- Always** route electrical cables carefully. Avoid moving parts, components that become hot and rough or sharp edges.
- Always** insulate and protect all exposed wiring and electrical terminals.
- Always** perform regular inspections and maintenance on mounts and related hardware.





Installation Instructions

Rear Bumper

Product Number: W1350, W1351

Application: '99-Current Super Duty

I. Overview

Congratulations on your new purchase of the industries' best and most stylish Ford bumper! This bumper has been **engineered** for strength while keeping the weight down.

Your bumper was designed in 3-D from digitized data, CNC laser cut, fabricated, and powder coated... all in the U.S.A.

Enjoy the fit and finish of a quality Ford bumper from Fab Fours Inc.

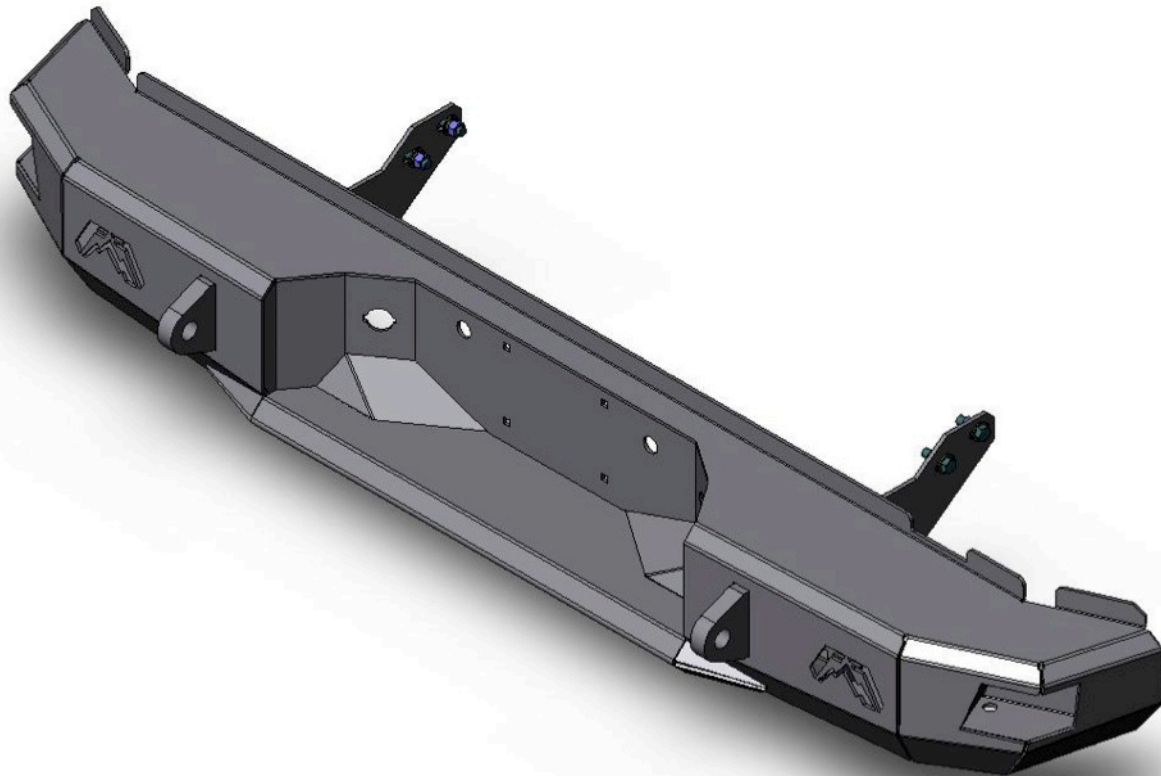



Installation Instructions

Rear Bumper

Product Number: W1350, W1351

Application: '99-Current Super Duty

II. Tools Needed

- 21mm or 13/16 Socket
- 3/4" Socket
- 3/4" Wrench
- Socket wrench
- Flathead Screwdriver

III. Removal

- Disconnect wiring harness (ref. figure 1).



Figure 1

- B)** With help and the use of a floor jack to support bumper, use a 13/16 or 21mm socket to remove the nuts and bolt straps securing the OEM bumper to the frame (ref. figure 2a-b).





Installation Instructions

Rear Bumper

Product Number: W1350, W1351

Application: '99-Current Super Duty



Figure 2a



Figure 2b





Installation Instructions

Rear Bumper

Product Number: W1350, W1351

Application: '99-Current Super Duty

- ❑ C) Remove license plate, and OEM license plate lights. Rotate the tag light and pull out of light housing using a flathead screwdriver to depress the plastic clip holding each tag light housing and push out of OEM bumper (ref. figure 3). Using a flathead screwdriver, pull out plastic anchors holding wiring harness to bumper. **If equipped with sensors**, push sensor housing tabs, indicated by circles, away from sensors and carefully wiggle sensors back and forth while pulling sensors out of housing (ref figure 3b).

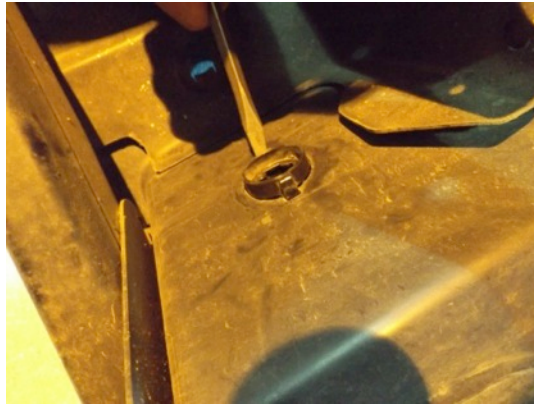

Figure 3a



Figure3b





Installation Instructions

Rear Bumper

Product Number: W1350, W1351

Application: '99-Current Super Duty

I. Pre-Installation

NOTE: PLEASE READ THE ENTIRE MANUAL BEFORE ATTEMPTING INSTALLATION. Ignoring these steps will increase your probability of scratching the vehicle during installation.

- A. Remove Fab Fours bumper from the shipping carton and lay all items out on a blanket to prevent damage.
- B. Install factory license plate lights in indicated locations.

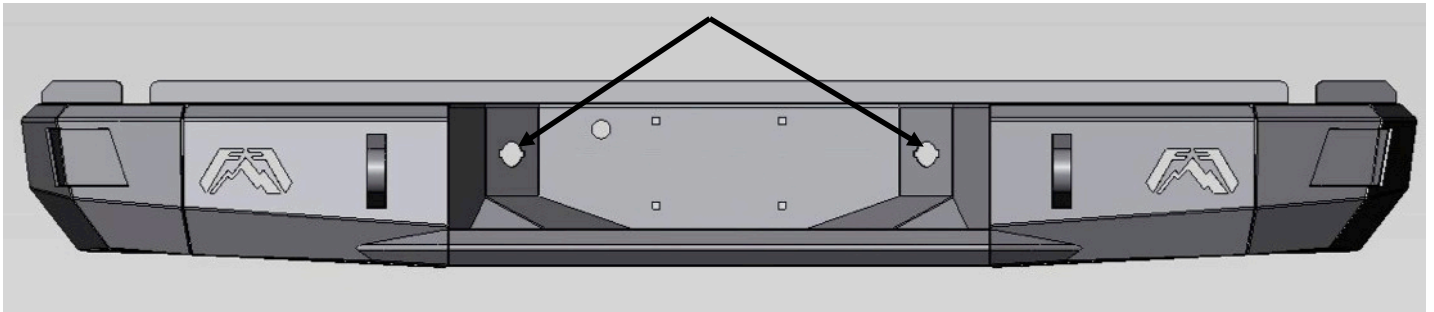

Figure 4

- C. **FOR SENSOR BUMPER INSTALLATION:** Install sensor housings in bumper by lining up plastic protrusions of the housing with the sensor profile (ref figure 5a-f).
- Look at images below to confirm proper orientation. Figure 5b is a cut away view with numbered sensors locations.
- At this time follow instructions on the provided epoxy. Making sure sensor housings are flush, then apply epoxy to inside face of bumper where housing sticks through.
- Run sensor harness through D-ring mount brackets (ref. figure 3).
- Ensure that the clear plastic grommet is on properly and sensors appear centered in their housings.
- Final installation of sensors on driver side should appear as follows with passenger side sensors mirrored.

Figure 5a





Installation Instructions

Rear Bumper

Product Number: W1350, W1351

Application: '99-Current Super Duty

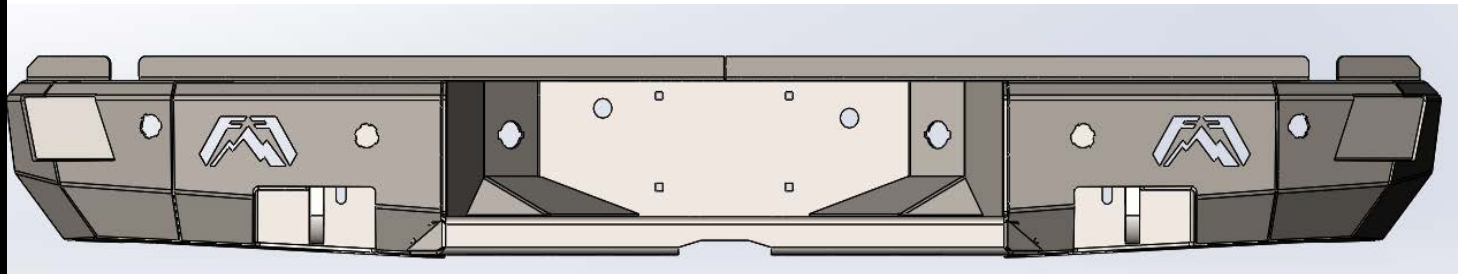
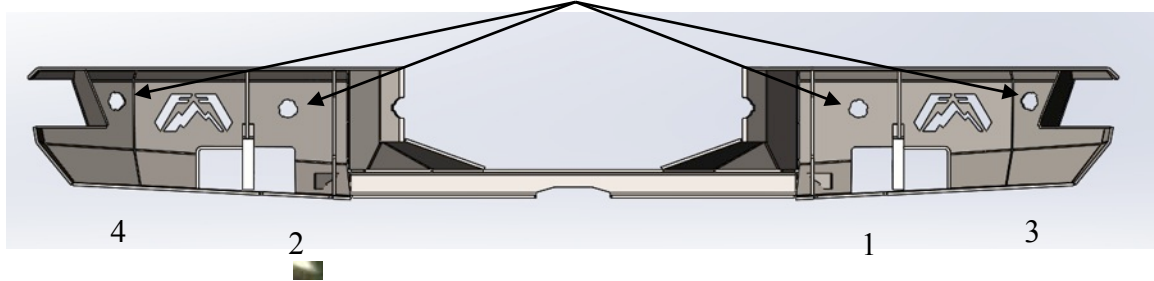

Figure 5b

[cutaway image showing all sensor holes including behind mounting plates]





Installation Instructions

Rear Bumper

Product Number: W1350, W1351

Application: '99-Current Super Duty



Figure 5c (loc. 2)



Figure 5d (loc 1)



Figure 5e (loc. 4)



Figure 5f (loc. 3)

IV. Installation

- A) Install bumper mounts (finger tight) onto bumper as shown using supplied mounting hardware. Verify that the stepped flange points upward. Repeat for other side.





Installation Instructions

Rear Bumper

Product Number: W1350, W1351

Application: '99-Current Super Duty

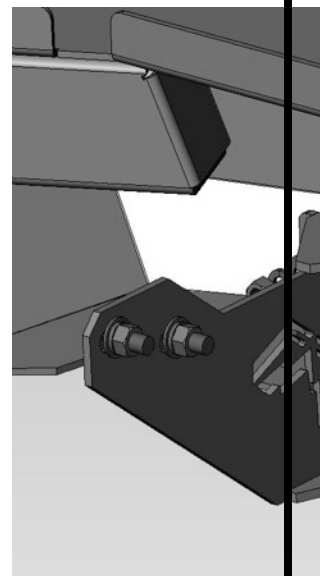
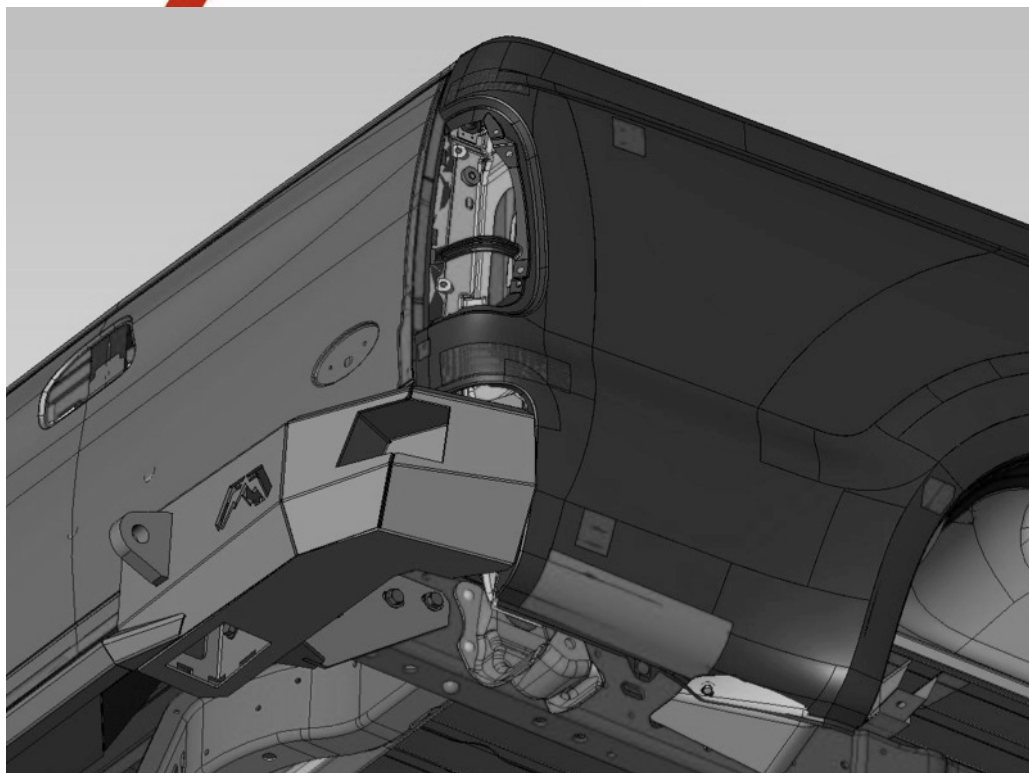

Figure 1

- B) Bolt bumper to mounts using supplied

hardware. Repeat for other side.

Figure 2

- C) Align bumper front to back and tighten frame mount fasteners.
- D) Align bumper height side-to-side, verify tailgate clears while lowered, and tighten bumper mounting fasteners using $\frac{3}{4}$ " socket and wrench.
- E) Plug in license plate light harness and secure to frame rails.
- F) Install license plate mounting inserts and re-install license plate.
- G) Install supplied hole plug into appropriate hole depending on year
 - 99-07: Plug Driver Side Hole
 - 08-Current: Plug Passenger Side Hole





Installation Instructions

Rear Bumper

Product Number: W1350, W1351

Application: '99-Current Super Duty

V. Maintenance/Care

- Periodically check and tighten all fasteners.
- Stripped, fractured, or bent bolts or nuts need to be replaced.



More than expected... Better than expected

