



**INSTALLATION MANUAL**  
**PREMIUM REAR BUMPER**  
**PRODUCT NUMBER: W445X**  
**APPLICATION: 2019 DODGE HD**



## **IMPORTANT SAFETY GUIDE** | Your safety and the safety of others is very important.

In order to help you make informed decisions about safety, we have provided the following warnings, safety precautions, installation instructions, and other important information to alert you to potential hazards that could hurt you or others.

Please do a job safety analysis before each task to identify potential hazards for your situation and remove/protect against them. Use own good judgment and take your time.

Check packaged materials immediately upon arrival to ensure that all listed parts are included and undamaged.

**Read and understand all warnings, safety precautions, and instructions before installing this product.**

SENSORS FIELD OF VIEW MAY BE ALTERED WITH USE OF THE REPLACEMENT BUMPER.

---

### **WARNINGS**

- Failure to observe the following warnings and instructions provided in this manual could lead to severe injury and/or death.
- For professional installation only. Careless installation and/or operation can result in serious injury, death, and/or equipment damage. All liability for installation and use rests with the user or consumer.
- Fab Fours, Inc. only approves installing this product according to these written instructions with the hardware provided. Failure to install according to these instructions will invalidate the warranty. This includes, but is not limited to, using alternative installation methods, hardware, or materials.
- This product is for off road use only.

---

### **SAFETY PRECAUTIONS**

- Always remove jewelry and wear eye protection.
- Always use extreme caution when jacking up a vehicle for work. Set emergency brake and use tire blocks. Locate and use the vehicle manufacturers designated lifting points. Use jack stands.
- Always use appropriate and adequate care in lifting components into place.
- Always ensure components will remain secure during installation and operation.
- Always wear safety glasses when installing this kit. A drilling operation will cause flying metal chips. Flying chips can cause serious eye injury.
- Always use extreme caution when drilling a vehicle. Always disconnect power before welding. Thoroughly inspect the area to be drilled (on both sides of material when possible) prior to drilling, and relocate any objects that may be damaged.
- Always use extreme caution when welding a vehicle. Thoroughly inspect the area to be welded (on both sides of material when possible) prior to welding, and relocate any objects that may be a fire hazard. When welding in a cab, make sure the interior surfaces are covered (e.g., welding blanket) and a fire extinguisher is at hand.
- Always use extreme caution when cutting and trimming during fitting.
- Always tighten all nuts and bolts securely per installation instructions.
- Always route electrical cables carefully. Avoid moving parts, components that become hot, and rough or sharp edges.
- Always insulate and protect all exposed wiring and electrical terminals.
- Perform regular inspections and maintenance on mounts and hardware.

# TABLE OF CONTENTS

- 2 SAFETY / DISCLAIMER
- 3 TABLE OF CONTENTS
- 4 A MESSAGE FROM THE OWNER
- 5 GETTING STARTED
- 6 PROVIDED MATERIAL
- 7 DISASSEMBLY
- 11 INSTALLATION

# A MESSAGE FROM THE OWNER

---



Fab Fours' was born out of a passion for customizing vehicles and a love of the outdoors. Our engineering team uses the latest 3D design software to turn new product ideas into reality. In our factory, designs come to life with the combination of cutting edge technology for metal cutting and forming and an American workforce that puts its' heart and pride into every product.

From design and manufacturing, to quality and delivery, Fab Fours' mission is to be the market leader for steel truck and jeep accessories. We make sure a quality product is delivered on time, more than expected, better than expected to our customers.

Enjoy your new Fab Fours product. Welcome to the family!

*Ereg Higgs*

**FOUNDER, FAB FOURS**

# GETTING STARTED

---

Before you begin the installation process of your new Fab Fours product, we suggest laying out all materials and parts on a pad or protective surface.

Failure to fully account for all components before beginning installation may leave vehicle immobile until part is acquired. Refer to the next pages as an inventory check.

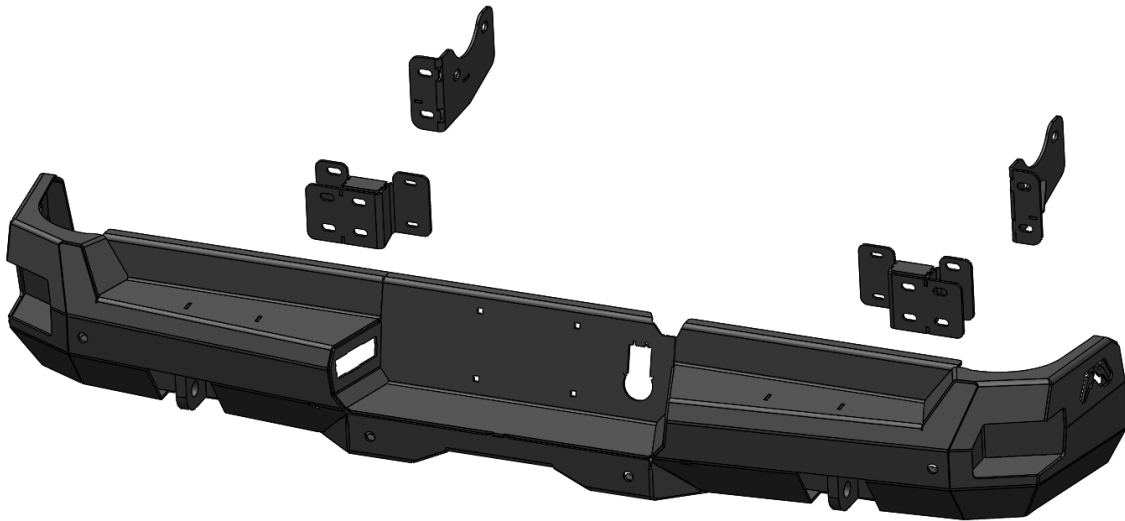

# PROVIDED MATERIALS



EPOXY

61632  
QTY: 2

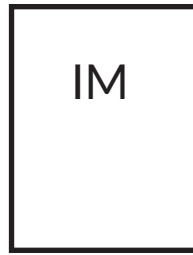

IM

W445X-IM



HW  
KIT

50189-HW

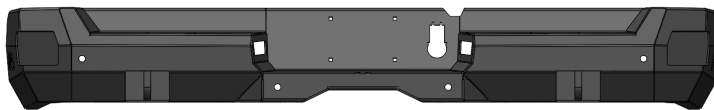

21951-W



21952



21953

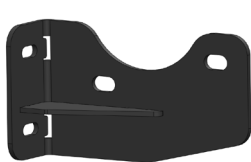

21961

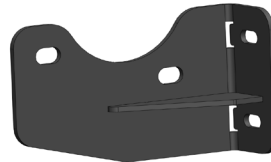

21960

## HARDWARE KIT | 50189

FAB FOURS IDENTIFICATION	COMPONENT DESCRIPTION	QTY
50189-HW	1/2"-13 x 1.25", Yellow Zinc Hex Cap Bolt, Grade 8	8
50189-HW	1/2"-13 x 1.50", Yellow Zinc Hex Cap Bolt, Grade 8	4
50189-HW	1/2", Yellow Zinc Hex Nut, Grade 8	12
50189-HW	1/2", Yellow Zinc Flat Washer, Grade 8	24
50189-HW	1/2", Yellow Zinc Lock Washer, Grade 8	12
50189-HW	1/2", Plastic License Plate Nut	4

## TOOLS REQUIRED

- Plastic panel pry tool
- Strong adhesive tape
- Adjustable wrench
- 10mm socket wrench
- 15mm socket wrench
- 24mm socket wrench
- (2) 3/4" open end wrench
- T20 torx bit
- Flat head screw driver
- Zip-ties

## ASSISTANCE

We recommend two people perform the installation as items are heavy and may need to be held in place while installing.

## ORGANIZATION

Disassemble the vehicle where you can catalog and store everything. We suggest labeling and bagging all the OEM bolts when removing from the vehicle. Failure to keep track of parts could lead to an inability to properly reinstall components.

# DISASSEMBLY

1. Using a 15mm socket wrench, remove the two (2) nuts from behind the license plate. (Figure 1)

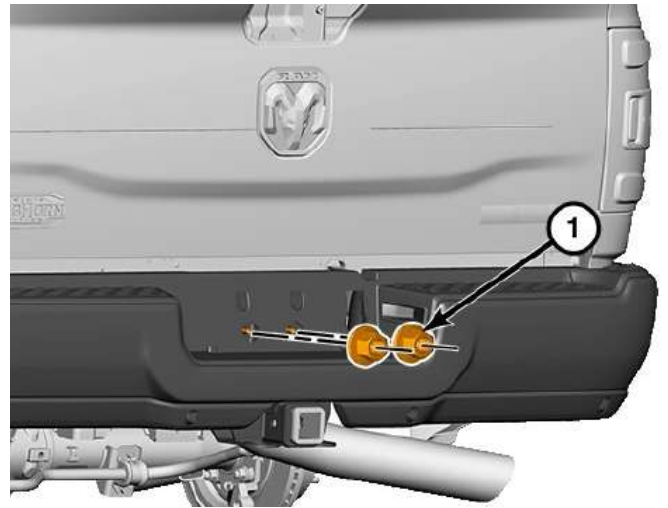

Figure 1

2. Disconnect the sensor and trailer plug harness by pulling back the red tab and separating the connectors. (Figure 2)



Figure 2

3. Using a 15mm socket wrench, remove the two (2) bolts connecting the bumper to the frame on both the driver and passenger side. (Figure 3)

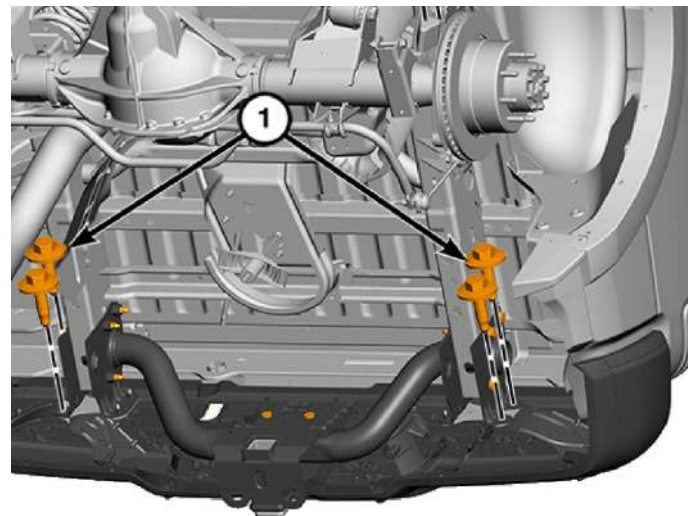

Figure 3

4. With assistance, remove the bumper from the truck. Using a 10mm socket wrench, remove the two (2) bolts and support plates from the frame rails on both the driver and passenger side. (Figure 4, #1)

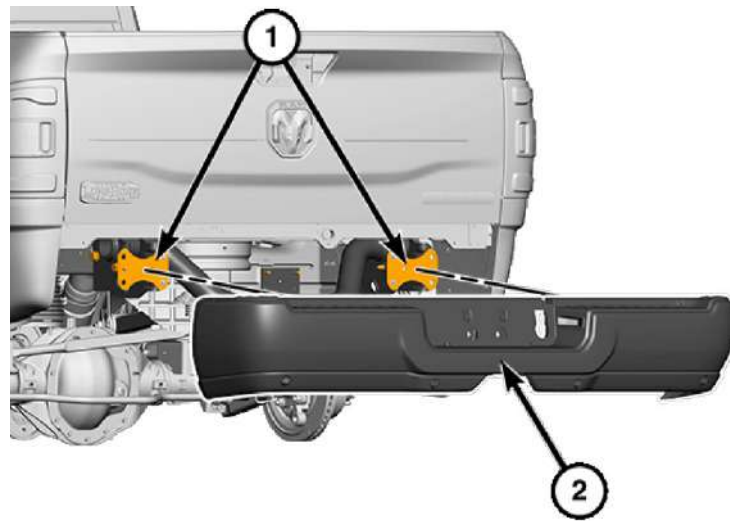

Figure 4

5. With the bumper off the truck, carefully unplug the wire harness from the trailer plug, license plate lights, keyless entry sensor and sensors. Using a plastic panel pry tool, remove the fasteners holding the harness to the OEM bumper. Remove the harness from the bumper and set aside for later use. (Figure 5-6)



Figure 5



Figure 6



6. Carefully remove the four (4) sensors from the OEM bumper by separating the fastening clips (Figure 7, #1) and lifting the sensor (Figure 7, #2) out of its housing.

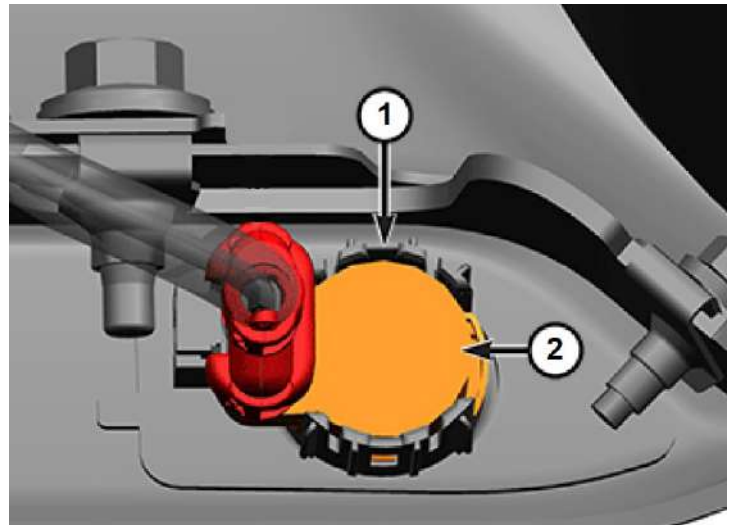

Figure 7

7. Using a 10mm socket wrench, remove the bolt holding the license plate lights in place and remove the lights from the OEM bumper. (Figure 8)



Figure 8

8. If equipped, using a T20 torx bit, remove the keyless entry sensor from the OEM bumper. (Figure 9)



Figure 9

---

9. Remove the trailer plug from the OEM bumper by depressing the two (2) metal clips on the sides and pushing the plug out of the bumper. (Figure 10)

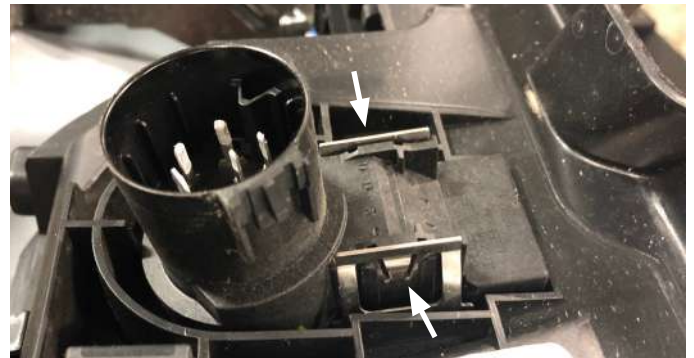

Figure 10

10. Figure 11 shows the components that will be used in your new Fab Fours bumper.



Figure 11

# INSTALLATION

11. Using strong adhesive tape, align and secure both license plate lights into the appropriate holes from the outside of the bumper. (Figure 12)



Figure 12

12. Using the provided two stage epoxy (61632), apply epoxy to both the top and bottom edge of the light where it passes through the bumper shell. Allow appropriate time for the epoxy to set before proceeding further. (Figure 13)



Figure 13

13. Loosely install the provided passenger side bracket (21953) to the provided bumper (21951) using the provided four (4) 1/2"-13 x 1.25" yellow zinc bolts, eight (8) flat washers, four (4) lock washers and four (4) nuts. (50189-HW) (Figure 14-15)

*NOTE: Use the access hole on the inner side of the bumper mount to position the 1/2" bolt and flat washer through the mounting slots (Figure 14).*



Figure 14

14. Loosely install the provided driver side bracket (21952) to the provided bumper (21951) in the same manner as described in step 13.



Figure 15

15. Insert the factory trailer plug through the appropriate hole in the bumper. Using a flat head screwdriver, lift and spread the trailer plug locking tabs to the back side of the bumper shell. (Figure 16)



Figure 16

16. Using an adjustable wrench, spread all the sensor clip tabs so the sensors may fit freely between them. (Figure 17)



Figure 17

*NOTE: Figures 18 and 19 show the inside of the passenger side wing and is intended to illustrate the sensor orientation for both the inner and outer sensors on that side. Both sensors in the driver side will install in a mirrored orientation.*



Figure 18



Figure 19

**17. Fully seat the sensor into the sensor cup. Be mindful of the sensor alignment as viewed from the outside of the shell. (Figure 20)**

*NOTE: The rubber seat of the sensor must not be pinched or distorted in any way for proper sensor installation. Failure to use or pinching of the rubber seat may result in false readings or non-responsive sensors. The sensor rubber seat is indicated in Figure 20.*

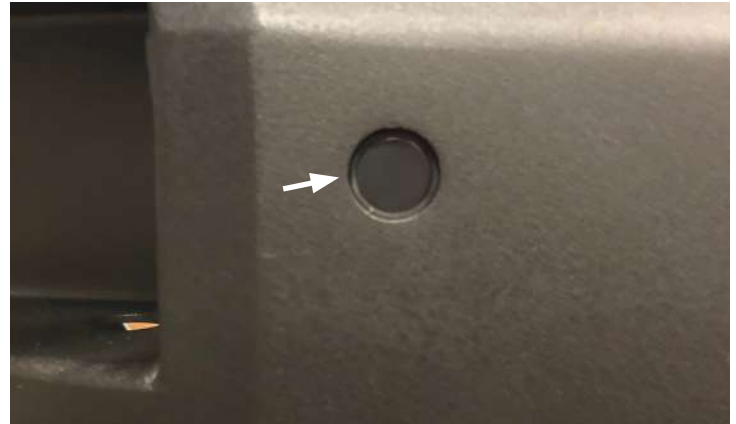

Figure 20

**18. While holding the sensor fully seated in the hole and sensor tabs aligned with the cutouts in the sensor cup bracket, bend the sensor cup bracket tabs back into place and tight to the sensor body. (Figure 21)**

**19. Follow the same installation method for all four (4) sensors being mindful of sensor orientation.**

**20. Lay and center the wiring harness along the bottom of the back side of the bumper with the factory harness connectors terminating on the driver side of the shell.**

**21. Begin connecting all the factory wiring harness connectors to the trailer plug, two (2) license plate lights, four (4) back up sensors, and one (1) keyless entry sensor if equipped.**



Figure 21

**22. Using zip ties, attach the harness to the zip tie locations cut into the bottom edge of the bumper shell. If equipped, bundle the keyless entry sensor with the harness and secure with a zip tie. (Figure 22-23)**



*Figure 22*



*Figure 23*

**23. Using a 24mm socket wrench, remove the two (2) lower bolts from the frame rail on both the driver side and passenger side frame rail end. (Figure 24)**



*Figure 24*

24. Loosely install the provided driver side frame rail stiffener bracket (21960) and passenger side frame rail stiffener bracket (21961) using the four (4) frame rail bolts removed in step 23. (Figure 25-26)



Figure 25

25. With assistance, lift the bumper assembly up to the frame rail. Loosely install the two (2) factory bolts and the provided two (2) 1/2"-13 x 1.50" yellow zinc bolts, four (4) flat washers, two (2) lock washers, and two (2) nuts on each frame rail. (50189-HW)



Figure 26

26. Center the bumper with the vehicle. Using a 10mm wrench, and a pair of 3/4" open end wrenches fully tighten down the provided four (4) factory bolts and provided four (4) 1/2"-13 x 1.50" hardware securing the frame rail brackets (21952,21953) to the frame rails.

27. Using a 24mm socket wrench, fully tighten down the four (4) lower frame rail bolts installed in step 23.

---

28. With assistance, lift and level the bumper to the body leaving a uniform gap all around the bumper to vehicle. Using a pair of 3/4" open end wrenches, fully tighten down the remaining eight (8) 1/2"-13 x 1.25" bolts securing the bumper shell (21951) to the frame rail brackets (21952,21953).

29. Insert the provided four (4) nylon license plate nut inserts into the four holes on the bumper. (50189-HW) (Figure 27)



*Figure 27*

30. Reconnect the factory wiring harness to the vehicle and test all your lights and sensors.