



Installation Instructions

2010+ Ram HD Front Replacement Bumper

Product Number: S2950

Application: 2010+ Ram 2500, 3500, 4500, & 5500 Trucks

SAFETY

Your safety and the safety of others is very important.

- In order to help you make informed decisions about safety, we have provided installation instructions and other information.
- These instructions alert you to potential hazards that could hurt you or others.
- Please do a job safety analysis (JSA) before each task to identify potential hazards for your situation and remove/protect against them.
- You must use your own good judgment, and take your time.

Read and understand all safety precautions and instructions before installing this product.

THIS PRODUCT IS FOR OFFROAD USE ONLY. ALL LIABILITY FOR INSTALLATION AND USE RESTS WITH THE OWNER.

CARELESS INSTALLATION AND OPERATION CAN RESULT IN SERIOUS INJURY OR EQUIPMENT DAMAGE.

Injury hazard

Failure to observe these instructions could lead to severe injury or death.

- Always** remove jewelry and wear eye protection.
- Always** use extreme caution when jacking up a vehicle for work. Set emergency brake and use tire blocks. Locate and use the vehicle manufacturers designated lifting points. Use jack stands.
- Always** use appropriate and adequate care in lifting components into place.
- Always** insure components will remain secure during installation and operation.
- Always** wear safety glasses when installing this kit. A drilling operation will cause flying metal chips. Flying chips can cause serious eye injury.
- Always** use extreme caution when drilling on a vehicle. Thoroughly inspect the area to be drilled (on both sides of material) prior to drilling, and relocate any objects that may be damaged.
- Always** use extreme caution when cutting and trimming during fitting.
- Always** tighten all nuts and bolts securely per installation instructions.
- Always** route electrical cables carefully. Avoid moving parts, components that become hot and rough or sharp edges.
- Always** insulate and protect all exposed wiring and electrical terminals.
- Always** perform regular inspections and maintenance on mounts and related hardware.





Installation Instructions

2010+ Ram HD Front Replacement Bumper

Product Number: S2950

Application: 2010+ Ram 2500, 3500, 4500, & 5500 Trucks

I. Overview

Congratulations on your new purchase of the industries' best and most stylish bumper available for the new 2010+ Ram Heavy Duty Trucks! This Bumper has been **engineered** for strength while keeping the weight down.

Your bumper was designed in 3-D from digitized data, CNC laser cut, fabricated, and powder coated... all in the U.S.A.

Enjoy the fit and finish of a quality Front Bumper from Fab Fours Inc.

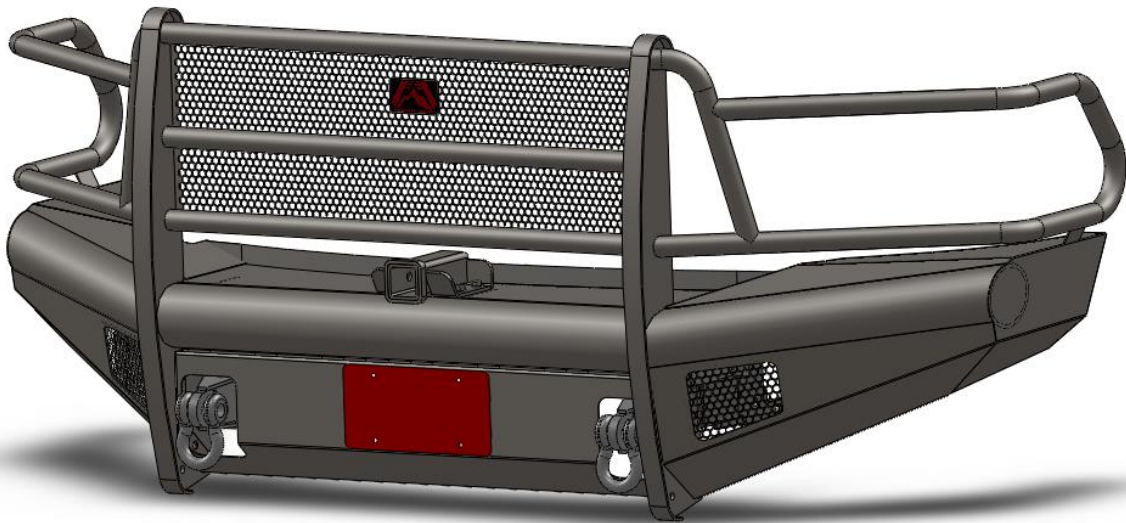

II. Tools Required

- 10, 13, 18mm, 3/4" Wrenches
- 18mm, 24mm, 3/4" Socket
- Socket wrench and short extension
- Test Light
- Assorted General Tools

III. Vehicle Preparation

1. **(DIESEL ONLY)** Open the hood and remove the dust shield covering the radiator and intercooler assembly.
2. **(DIESEL ONLY)** Remove the two screws attaching the intercooler to the top of the core support.
3. **(2013+ DIESEL ONLY)** Unbolt intercooler mount brackets from frame rails and disconnect intercooler hoses to move intercooler out of the way to access the bolt strips.

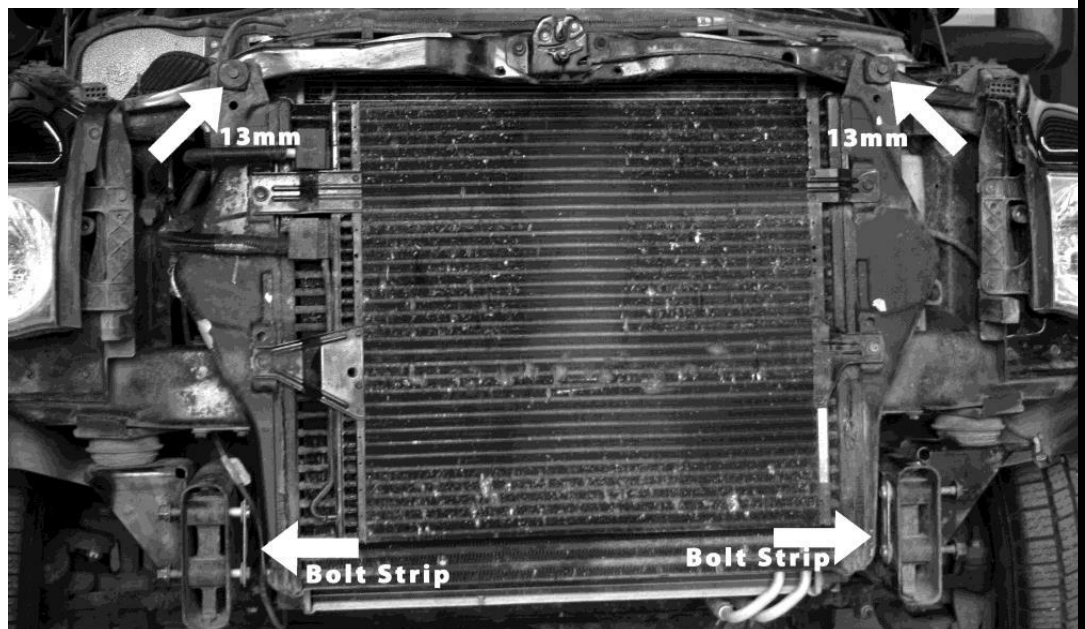

Figure 1 – Intercooler Fasteners

Installation Instructions

2010+ Ram HD Front Replacement Bumper

Product Number: S2950

Application: 2010+ Ram 2500, 3500, 4500, & 5500 Trucks

A. Disconnect the Fog Light harness on the driver side of the OEM bumper.

B. Open Hood and Remove “Heavy Duty” Dust Shield.



A. Remove the OEM lower air Dam by popping out the plastic clips.

Installation Instructions

2010+ Ram HD Front Replacement Bumper

Product Number: S2950

Application: 2010+ Ram 2500, 3500, 4500, & 5500 Trucks

B. Diesel Models Only: Remove the 10mm bolts holding the top of the intercooler to the radiator support.

C. Remove four 18mm nuts and two bolt strip holding the OEM bumper to the frame rails. Diesel Only: Move on side of the intercooler at a time to remove the bolt strips **BE CAREFUL NOT TO DAMAGE THE INTERCOOLER FINS.**

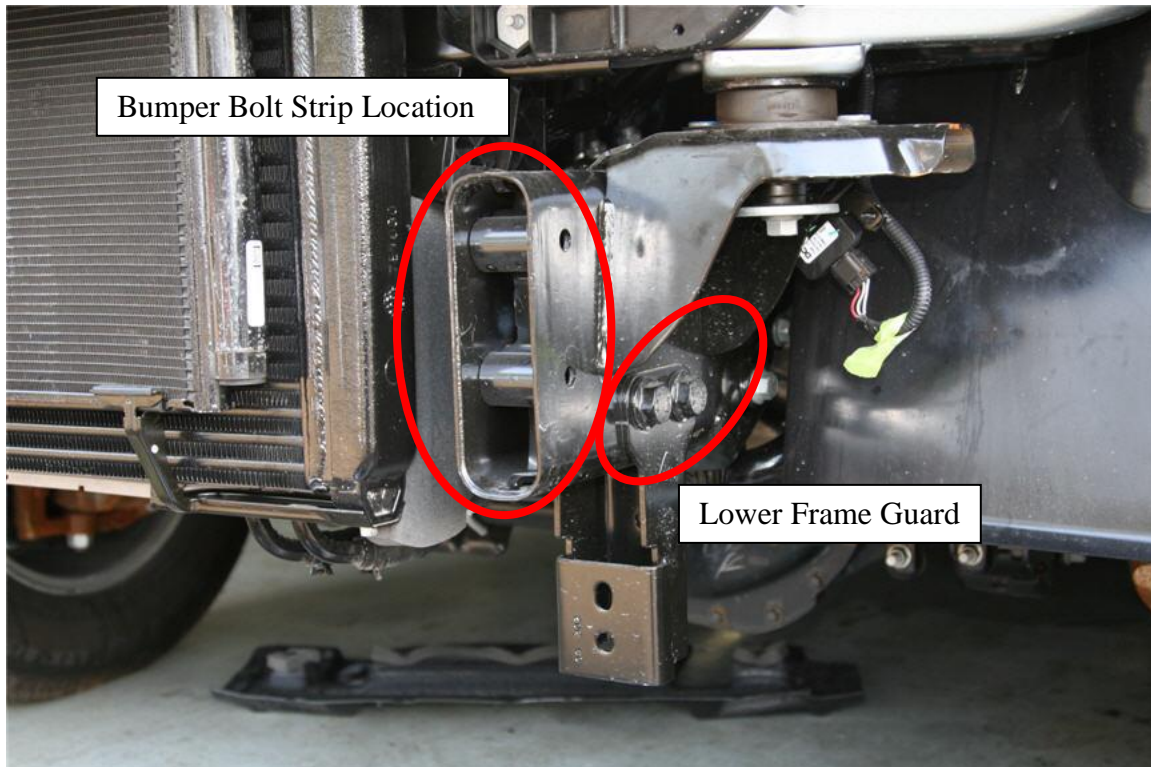

D. Remove the OEM Bumper and set aside.

E. Re-install the two bolts holding the top of the intercooler to the radiator supports.

F. Remove the Lower Frame Guards from using a 24mm socket and wrench.

IV. Winch Bumper Installation

NOTE: The Following Installation steps apply to the installation of the Bumper to the vehicle. PLEASE READ THE ENTIRE MANUAL BEFORE ATEMPTING INSTALLATION! Ignoring these steps will increase your probability of scratching the vehicle during product Installation!

1. Remove the Bumper from the shipping carton. Lay all items out on a blanket to prevent damage to the powder coating. Install lower guard (***IF INSTALLING A WINCH SEE WINCH TRAY INSTALLATION INSTRUCTIONS***) by rotating it into position from the bottom of the bumper as shown below. Install three ½" fasteners (Provided in hardware bag labeled 20260-HW) per side with bolt heads facing the inside of the bumper.

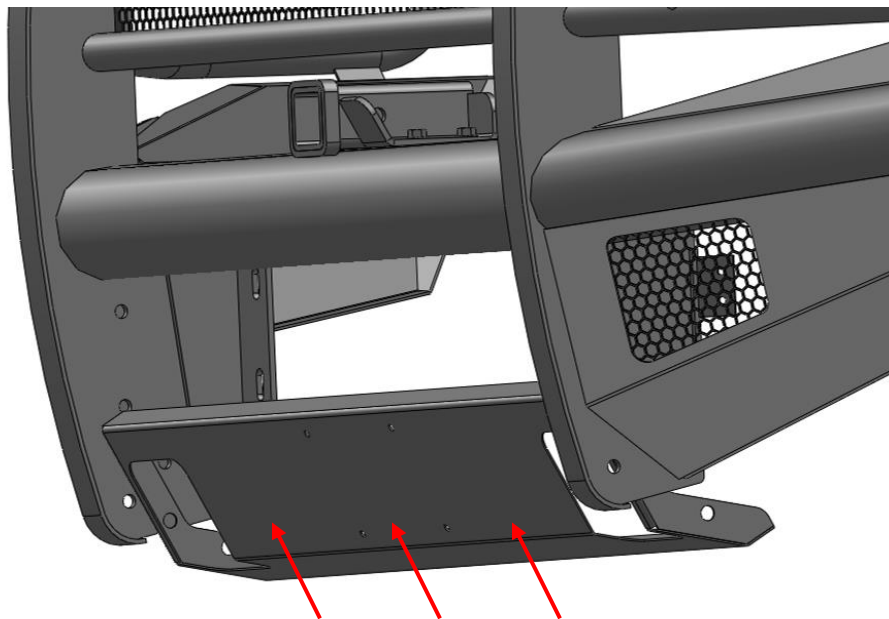

Figure 1 - Lower Guard Installation

2. **OPTIONAL:** If you wish to retain the stock fog lamps, remove the lights from the stock bumper and reinstall using OEM hardware in the provided brackets behind the protective mesh. It may be necessary to remove the adjuster screw prior to installation. With the fog light clipped in the bracket, reinstall the adjuster screw to clamp the light in place.
3. **OPTIONAL:** If installing your bumper with D-ring shackle mounts, they should be placed inside the bumper mounting brackets before final installation. Insert the shackle mounts from the front of the bumper as shown below.

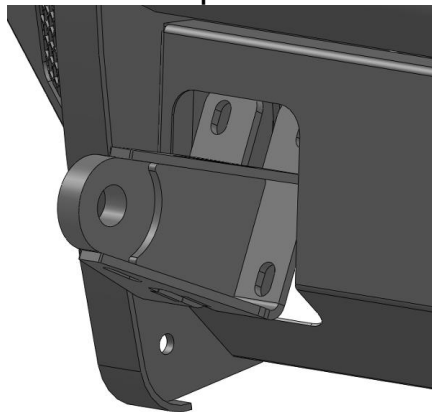

Figure 2 - Shackle Bracket Installation

4. **OPTIONAL:** If installing the 2" receiver hitch accessory, attach it to the bumper with the provided 1/2" hardware

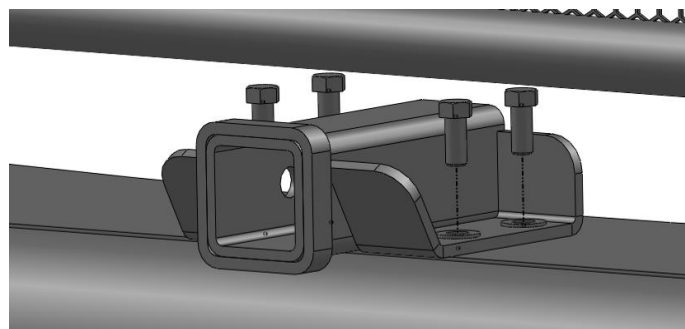
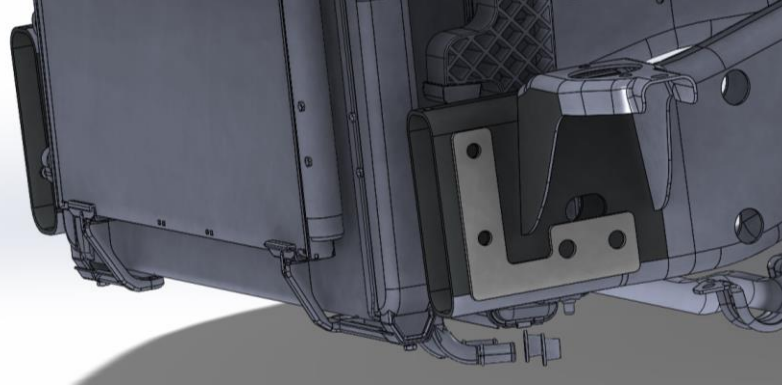

Figure 3 - Hitch Installation

5. Use the supplied drill template on the frame rail to locate the additional holes to be drilled out if all four holes are not present.



6. Install intermediate mount onto the frame rail using the 9/16" x 4" bolts and nuts through the FRAME UNDER RUN GUARD holes, and then replace the bolt strip in the original orientation. Insert all hardware from the inside out, with the nuts accessible from the outside of the frame rail. **DO NOT FULLY TIGHTEN**, repeat for other side.

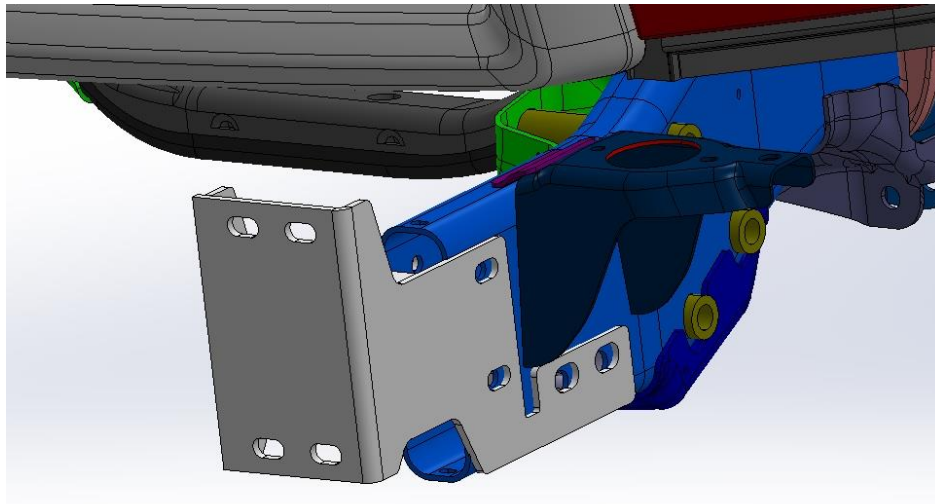
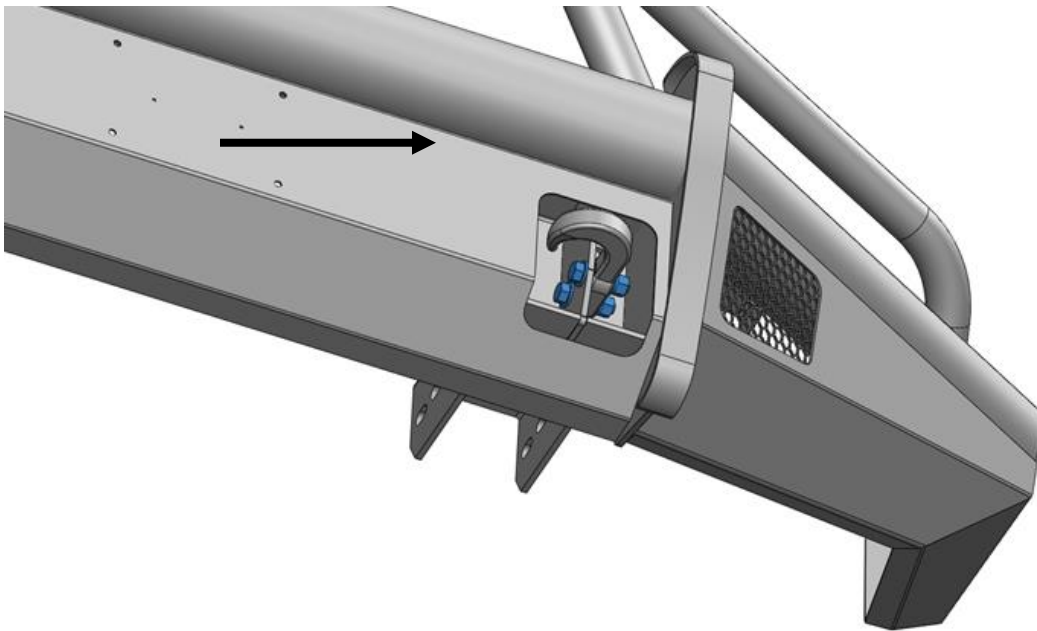

Figure 4 - Intermediate Bracket Orientation

7. Lift bumper and align mounting slots with the mating slots on the intermediate mounts. Install 9/16" mounting bolts but do not tighten fully. It may be helpful to support bumper with a floor jack(s) during install. Repeat for other side
8. Adjust and up/down and left right alignment with the intermediate mount bolts
9. Tighten all fasteners; beginning with frame mounts. Then tighten all mount-to-bumper fasteners.
10. Trim inner-fender liners to match bumper if desired.

Install the Supplied Tow Hooks in the orientation shown below (Open to the inside and on the outside of the brace) using the supplied 1/2"-13 bolts, washers, and nuts.





Installation Instructions

2010+ Ram HD Front Replacement Bumper

Product Number: S2950

Application: 2010+ Ram 2500, 3500, 4500, & 5500 Trucks

Installation Complete!

V. Maintenance/Care

- Check for loose fasteners after the first 100mi of driving (less for severe duty applications)
- Periodically check and tighten all fasteners.
- Stripped, fractured, or bent bolts or nuts need to be replaced.



More than expected... Better than expected

