



Classic™

1963-1972
C-10



First, put a little bit of EZ Tite around the thread of the fitting you are installing. This will keep air from leaking and ensure a tight seal.



Thread in your 1/2"x1/4" fitting into one of the ports on the front of your air tank. This fitting will supply air to your paddle valves.



On the neighboring port, plug it off using the supplied fitting and tighten with a Hex Key. You will not need to use this port.



Your Pet Cock will thread into the bottom tank port. Use this to drain condensation and debris.



Installing a pressure switch is easy. First, thread the pressure switch to the 1/4" reducer bushing. (don't forget the EZ Tite)



Next, thread the pressure switch and reducer to either side of the air tank.



On the opposite side of the tank connect your compressor.



Thread the last 1/4" reducer to the Viarr 444c Chrome Compressor.



Now, plug your compressor into the side port on the air tank. Simply, through our EZ Tank Bracket hole.

EZ Air Ride Single 444c Wiring Diagram

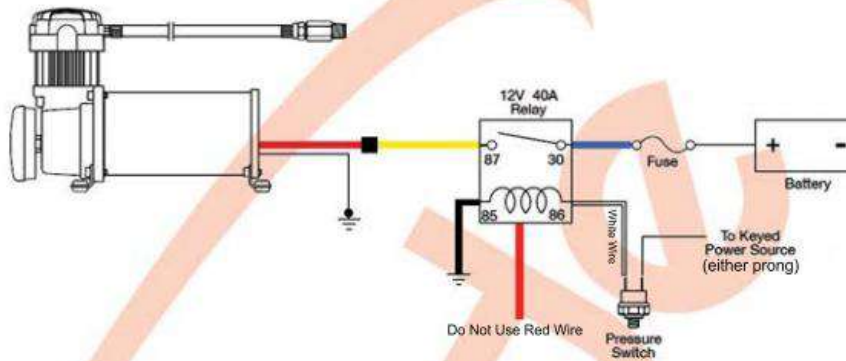

EZ Air Ride Dual 444c Wiring Diagram

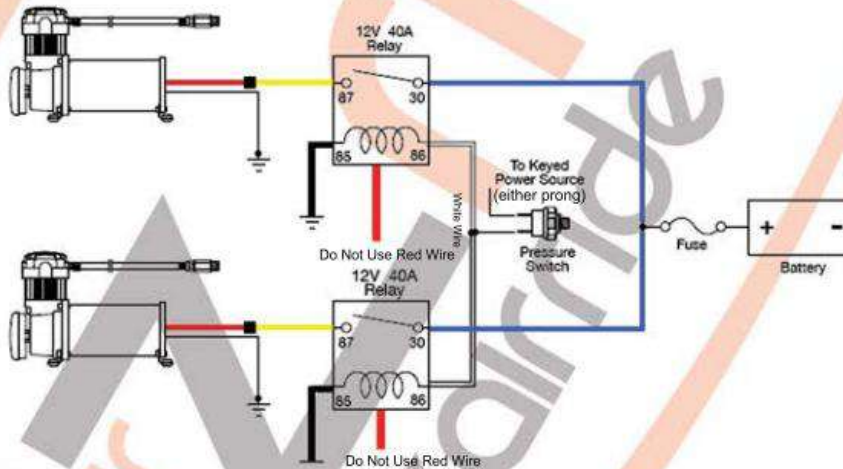

Ground Wire – The ground lead on the compressor should not be extended (if possible). Always connect ground leads directly to the chassis (frame) of the vehicle. Any other grounding method may result in amp spikes that may damage the compressor motor, as well as sporadic & undesired operation.

Wire Type - Fine stranded copper wire is the item of choice (more strands in the wire result in a better, more flexible, cable). The insulation should be approved for automotive applications. This means that the wire is relatively immune to the adverse effects of petroleum products (gas, diesel, oil, brake fluid, radiator coolant, etc.).

Relays –Always install relays as close to the battery as possible. Relays also help to increase the life expectancy of pressure switches in the system.



This is your new EZ Air Ride Classic gauge control panel. The dual needle gauge will monitor the air pressure in your air bags. The left paddle controls the front and the right controls the rear.



Use EZ Tite to secure the Red Head fittings on the back of the air gauge.



Next cut (2) strips of air line 2" in length.



Lubricate the Tee bar using glass cleaner to help insert it into the air line.



Now, cut (2) more strips of air line (1) at 1" and the other at 1/2"



Connect the 1" strip to the T on the barb and the 2" strip to either end.



Plug the 2" strip of air line into the delivery barb on the back of the paddle. This will be labeled "DEL."



Next, plug the 1" air line strip from the Tee to the Red Head gauge fitting.

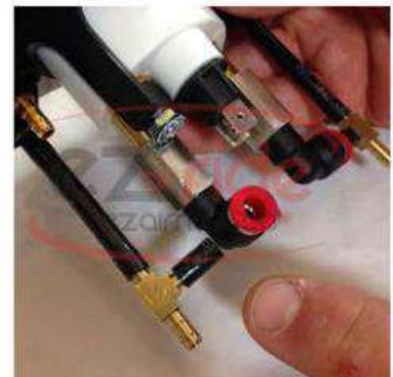

Connect the rear paddle valve the same way as the front. Use the 1/2" strip of air line for the gauge fitting. (this barb is closer to the gauge)



Once the delivery barb has been plumbed into the gauge, plug air line into the last remaining barb on the Tee.

Note: cut air line length according to the space you have under your dash or where ever you decide to mount your control panel



Now, attach a Wye fitting to the end of each "delivery" air line. On the left side, run air line to your front air bags. Use the right side to run air line to your rear bags.

Note: you can split at the Wye as close to the gauge or bags as you would like.

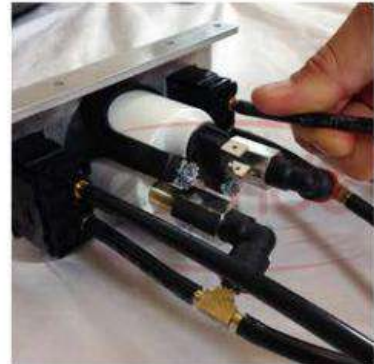

Now, plug 2 more strips of air line into the delivery barbs on the back of the gauge labeled "SUP." These barbs will "supply" air to your bags.



Lastly, take the "supply" air lines and plug them into a Wye fitting.



Run air line from the Wye into the fitting on the front of your air tank.



This tank fitting supplies air to the control panel.



63-72 C10s have to be the coolest and easiest of them all to install air ride. It is the only GM vehicle where the shock is mounted on the outside of the coil spring, therefore no relocating.



Safely remove your factory coil spring.

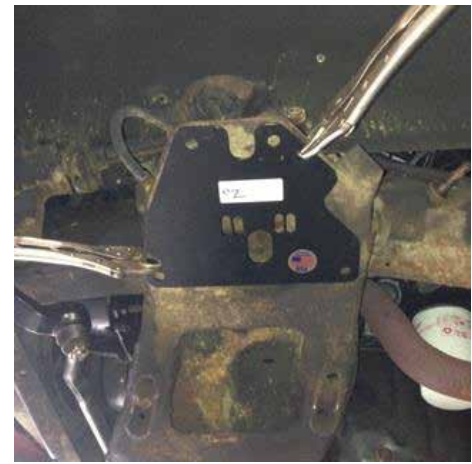

Once the coil spring has been removed use the front upper mounting plate as a template for drilling the 4 parameter holes on the upper crossmember.



Be sure to feed enough air line through your spring pocket to easily feed into the air bag as you bolt it up



Mount the upper mounting plate and the lower cup to the air bag as shown above, and thread in the air fitting.



Plumb the air line into the bag fitting before bolting the assembled bag/bracket to the crossmember.



Once the mounting plate has been safely bolted in place the lower cup will sit in the factory lower A Arm.

This kit has been designed to give you optimal drop. Don't let other companies strong arm you into spending thousands on custom control arms and fancy chrome plated shocks.

EZ Air Ride Single 444C Wiring Diagram

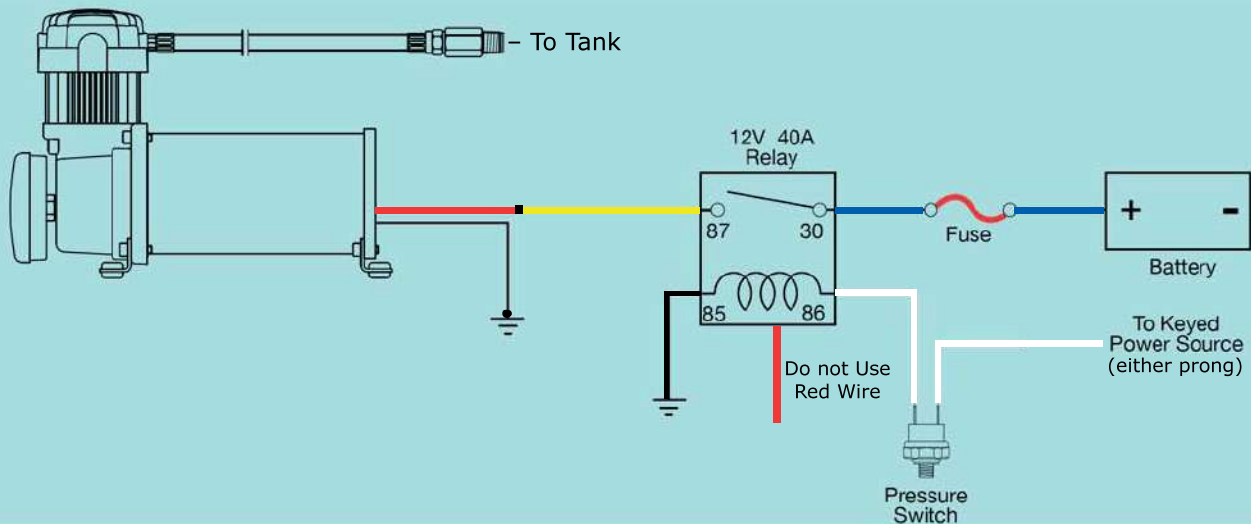

EZ Air Ride Dual 444C Wiring Diagram

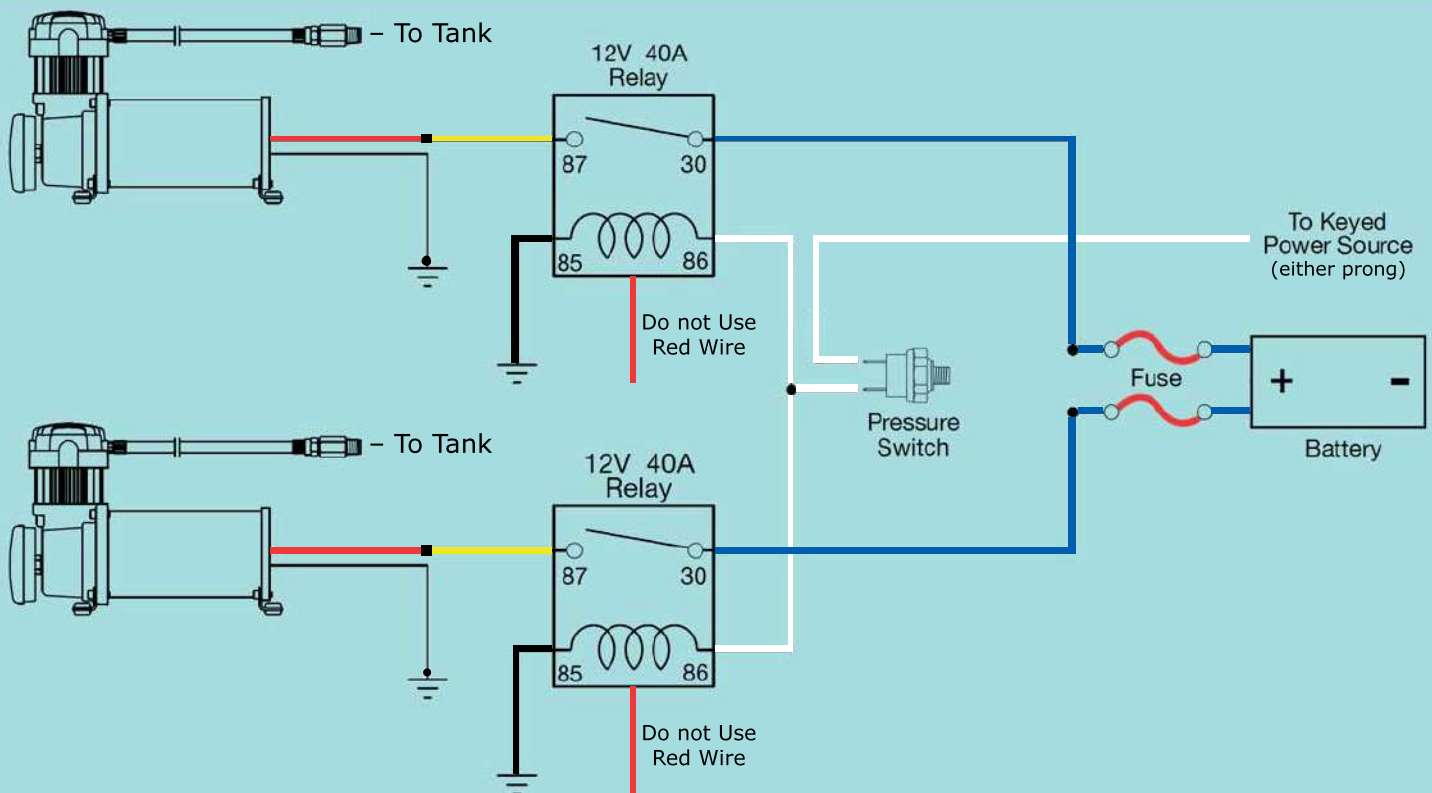

Ground Wire– The ground lead on the compressor should not be extended (if possible). Always connect ground leads directly to the chassis (frame) of the vehicle. Any other grounding method may result in amp spikes that can damage the compressor motor by causing sporadic and undesired operation.

Wire Type– Fine-stranded, copper wire is the item-of-choice. We only use Oxygen-free wire (more strands in the wire result in a better, more flexible cable). The insulation should be approved for automotive applications. This means that the wire is relatively immune to the adverse effects of petroleum products (gas, diesel, oil, brake fluid, radiator coolant, etc.).

Relays– Relays help to increase the life expectancy of pressure switches in the system.



Connect the "white capped" barb to the "white capped" valve marked DEL using 1/4" air line. Make sure you connect left to left and right to right.



Connect "red capped" barb to red head on gauge using 1/4" air line. Make sure you connect left to left and right to right.



Connect both "black capped" barbs marked SUP to the Wye fittings using 1/4" air line.



Complimentary wire harness ties into your fuse box/panel to light up your gauge. Connect red female terminal to LED bulb and then to your fuse panel. Connect black female terminal to LED bulb and then to ground.

*Be sure to remove the color coded caps from each barb before trying to connect tubing.

Trunk Upper Decks: Fits nicely on the upper deck in most trunks (under package tray).



Frame Rails: Fits in between the frame rails of 60-87 C10s, behind the rear axle.



Trunk: Sits comfortably in the trunk or compartment in most cars.

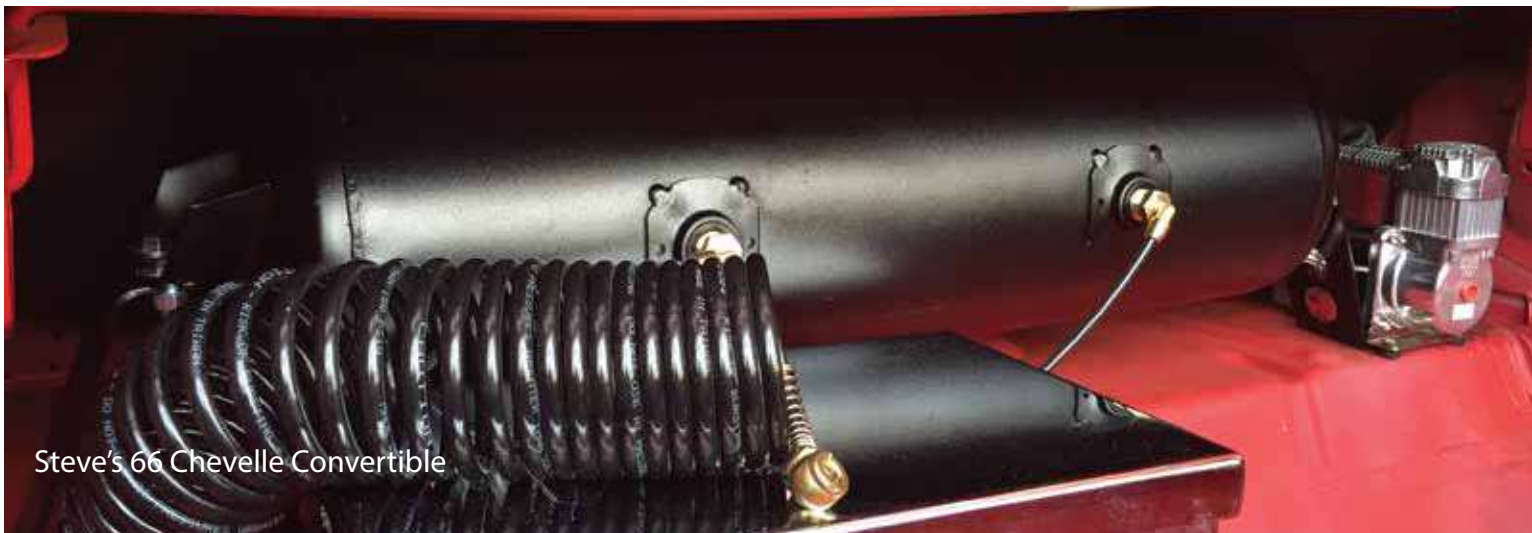



First, put a little bit of EZ Tite around the thread of the fitting you are installing. This will keep air from leaking and ensure a tight seal.



Thread in your 1/2"x1/4" fitting into one of the ports on the front of your air tank. This fitting will supply air to your paddle valves.



On the neighboring port, plug it off using the supplied fitting and tighten with a Hex Key. You will not need to use this port.



The Drain Cock will thread into the bottom tank port. This is used to drain any moisture.



Thread the Tee into the side of the air tank.



Next, thread the pressure switch into the tee. We suggest the backside leaving the front for you Spare Air™.



On the opposite side of the tank connect your compressor.



Thread the last 1/4" reducer to the Viar 444c Chrome Compressor.



Now, plug your compressor into the side port on the air tank. Simply, through our EZ Tank Bracket hole.



Your new EZ Air Ride™ suspension kit comes with our complimentary Spare Air™ system.
25' Coil Hose, Quick Connect, Brass Tee, Female Coupler, Schrader Valve, & Air Chuck



Connect the brass Tee to the side of the tank. Pressure switch (not shown) plugs into the back side and the quick connect plugs into the front.



Insert the supplied schrader valve into the female coupler.



Simply, push the assembled schrader valve into the quick connect.



Now use your shop's compressor for your tank's first fill, leaving your Viair compressors to just maintain tank pressure. They will love you for this... if they had a heart ;)



When finished replace the schrader valve with the supplied coil hose and air chuck. You now have onboard air!



MAINTAINING YOUR TANK?

Depending on your climate, how much you use you air ride system, and the overall humidity will determine how often you should drain your tank. Simply, use a frisbee and the complimentary shop towel to catch any water or debris. With that being said, you may want to start off by draining it once per month. Slowly open the drain cock, catch any moisture with your new shop towel, then tighten your drain cock. Your new Spare Air™ kit will make filling your tank back up a breeze!