

INSTALLATION

XCEED

extang
truck bed covers

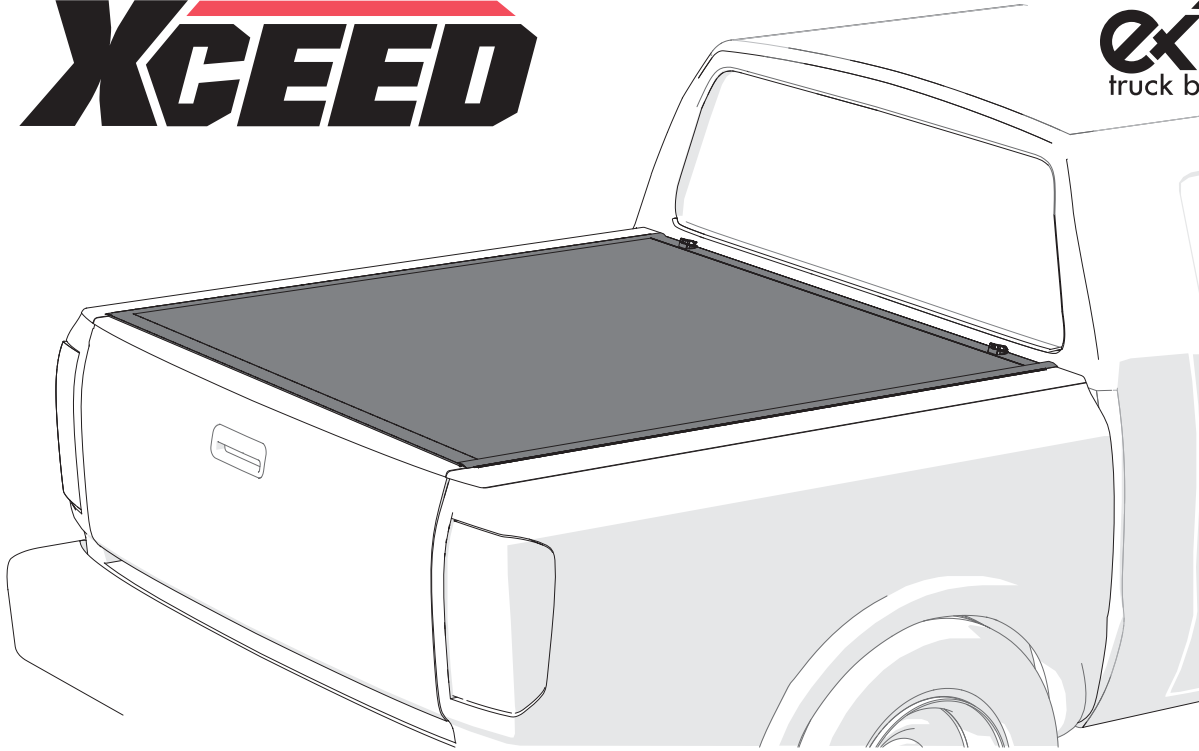

The XCEED truck bed cover requires the installation of rails and some small parts. Note any damaged or missing components before installing.

Tools required:
9/16" and 1/2" sockets and ratchet wrench,
Phillips screwdriver

1 It is important that all areas where the bed cover mounts are clean and free of debris prior to installing.



2 If the truck does not have a bed liner, install the cab/bulkhead seal. Wipe the painted surfaces with isopropyl alcohol before applying.

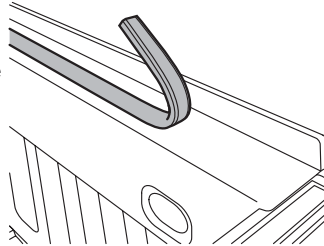

3 With the tailgate closed, place the Xceed rails on the truck bed rail with the slotted bracket forward toward the cab/front and facing inside.

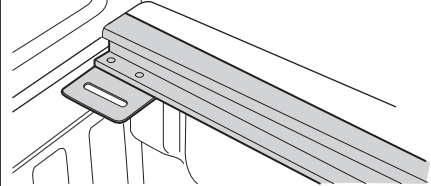

4 Make sure the rail is clamped square with the truck bed rail and bulkhead. Start at the front/cab and place the first clamp 6 to 9 inches (152 to 229mm) from the front.

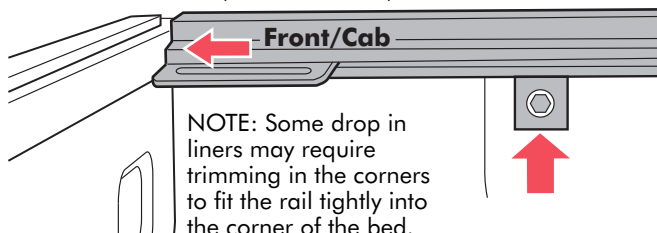

5 Make sure the clamp is inserted all the way up into the rail and clamp teeth are aligned to the rail slots to ensure grip.

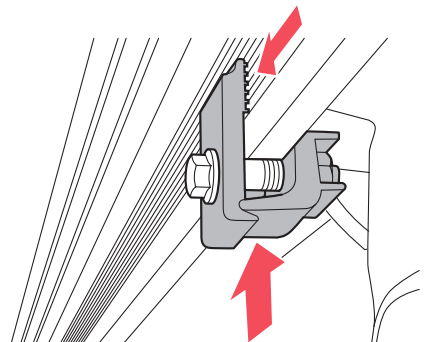

6 Place the 2nd clamp near the center of the rail.

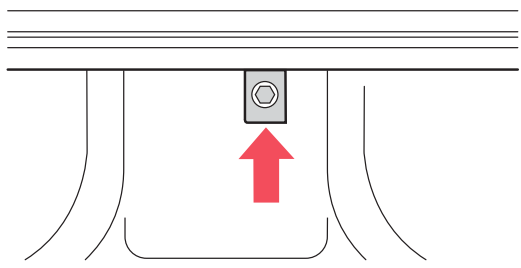

7 Place the rear clamp approximately 6 inches 152 mm from the tailgate. Tighten all the clamps to 10 ft-lb, 13,6 N-m.

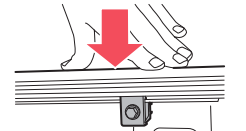
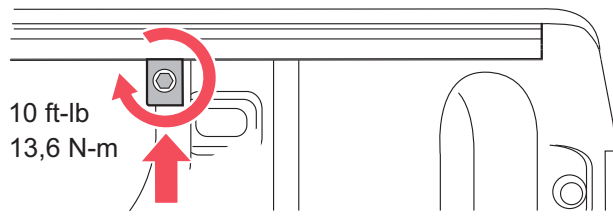

NOTE: Always apply downward pressure to the rail when tightening the clamps to ensure that the rail sets flush and seals properly.

8 Set the cover in the folded position, with the cab panel at the front onto the rails at the front/cab of the truck.

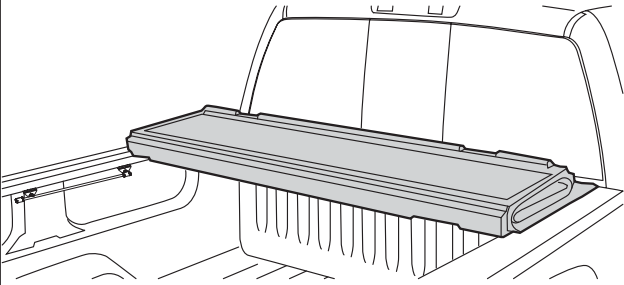

9 Before mounting the cover on the truck, using a screw driver install the two buckle ends into the pre-drilled holes on the front header panel. Insert the posts from the bottom, thread the screws down through the buckle end. **Do not over tighten, hand tighten, Do Not use a screw gun.**

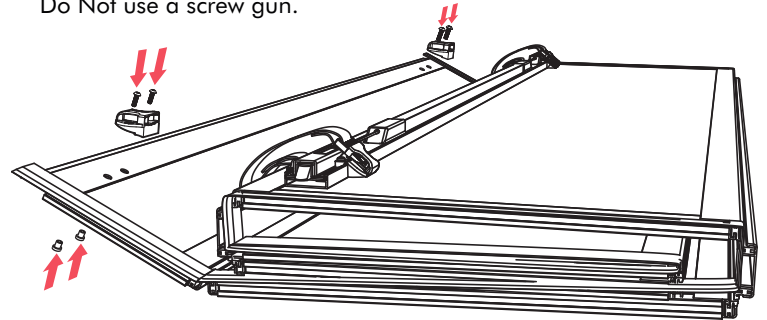

10 At the front cab, fold the header panel back and insert 2 mounting bolts through the keyed slots. When closed, the two screws will align with the slotted bracket of the cover rails. Repeat on the opposite side.

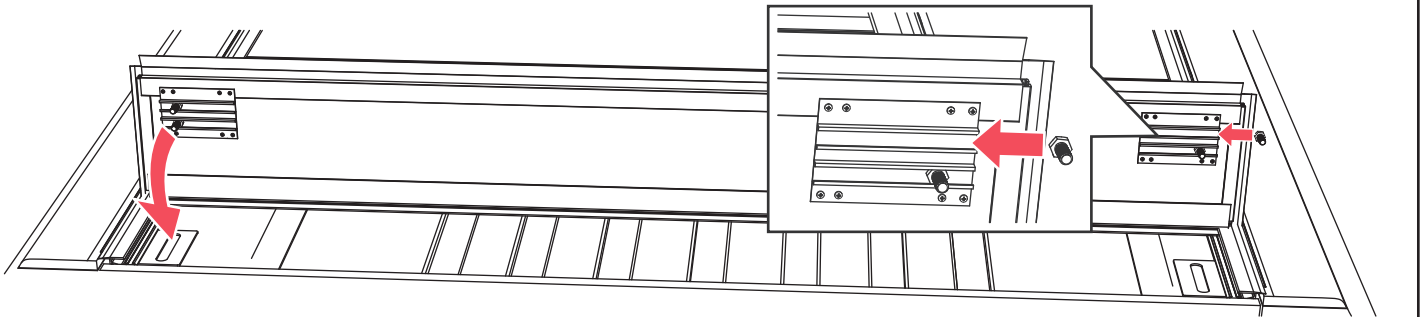

11 Install mounting hardware loosely underneath the slotted bracket on the rail. Start with the rubber washer, then the large flat washer, then the nylon lock nut. Install two on either side. **Leave the nuts loose for later adjustments.**

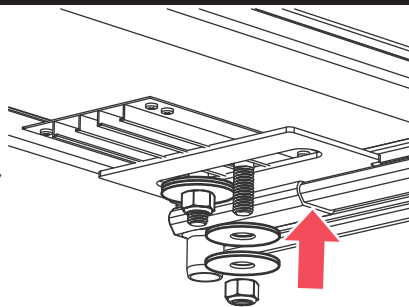

12 Unfold the cover toward the tailgate. Make sure the cover fits squarely between the rails.

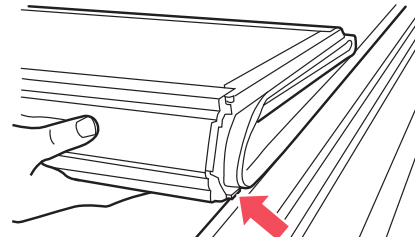

13

The cover's aluminum frame at the tailgate should just fit inside of the tailgate when the cover is correctly positioned from front to back. The clearance is approximately 1/4", 6.35mm.

The rear edge of the cover and tailgate seal should rest on top of the tailgate. The cover must also be parallel with the tailgate and truck bed.

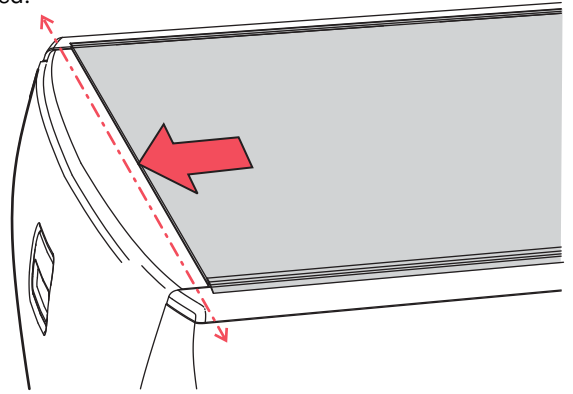
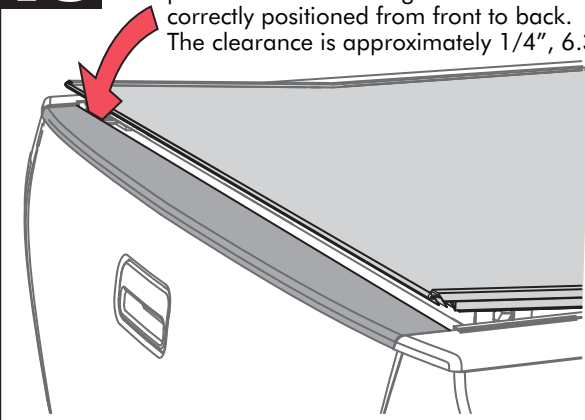

14

Check that the cover panel latches on both sides make proper contact with the side rails. Adjust the cover left to right so that both latches have equal engagement into the side rails.

15

Once the cover is properly aligned, carefully open the cover ensuring that it remains in position. Tighten the four mounting nuts. Do Not over tighten the fasteners, Do NOT use power tools.

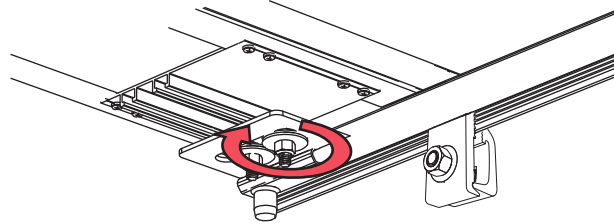
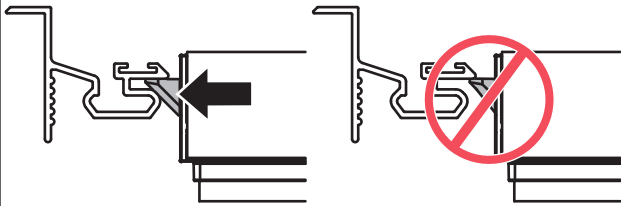

Check that the cover operates correctly and the latches engage, if not loosen the fasteners and realign.

16

Check for tail panel latch engagement. Check to see that both tail panel latches make proper contact with the side rails. If the tail panel latches do not contact properly, remove the small panel screw and slide the end cover off of the latch assembly. Loosen the two screws (remove and re-tighten screws by hand only) and slide the latch pall assembly to contact the rail. Check and adjust on both sides.

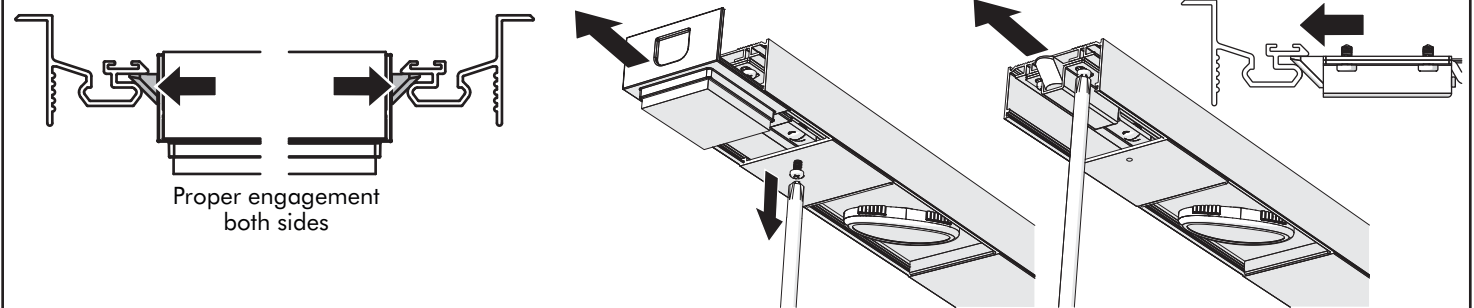

17

Attach the drain hoses to the front drains and route the hose through the manufacturer bed plugs. Remove the plug or drill a 7/8", 22.3mm hole in the bed plug. Install hoses on both sides. The hoses may have to run behind a drop-in bed liner.

18

Install three cab bumpers along the edge of the cover where it meets the truck cab in the propped up position.

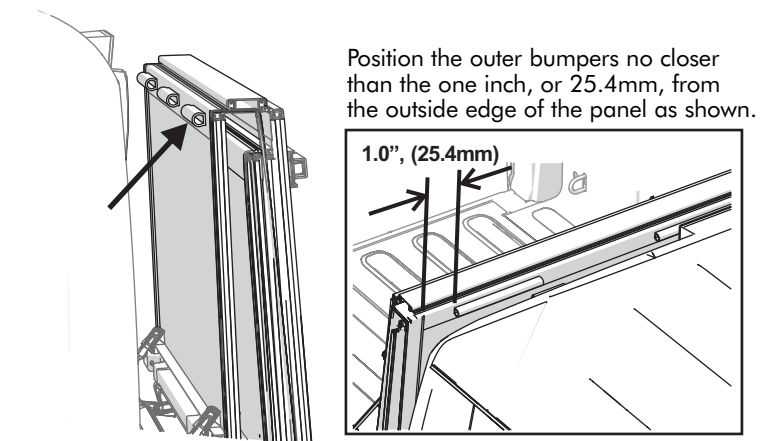
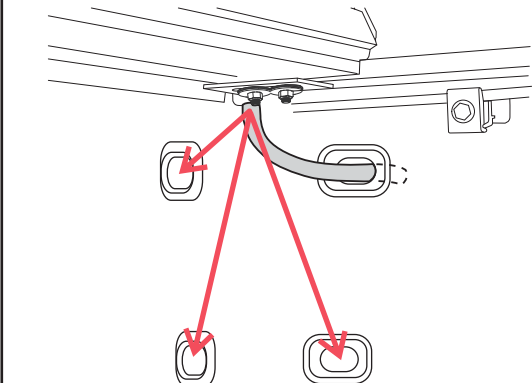

Position the outer bumpers no closer than the one inch, or 25.4mm, from the outside edge of the panel as shown.

1.0", (25.4mm)

IMPORTANT Bed cover safe operation and use

IMPORTANT NOTICE

While driving, the cover must be completely flat and secure with all latches in the closed position OR completely folded up (all panels) and secured at the cab. DO NOT DRIVE with cover partially opened.

Tonneau Cover Positions While Operating Vehicle

Prior to vehicle operation, the bed cover MUST be properly secured.

CLOSED POSITION

All panels must be flat, closed and FULLY LATCHED to the bed cover side rail.

FOLDED & SECURED FLAT AT FRONT OF BED

To drive with your bed cover in the folded position, use the tie down straps and buckles provided with your cover. Ensure that BOTH buckle clips are fully inserted into the buckle ends located on the front header panel of the cover, and adjust the straps to ensure the cover is secure during vehicle operation. The clips should be secured in the storage position, as shown in Figure 1, when the straps are not in use.

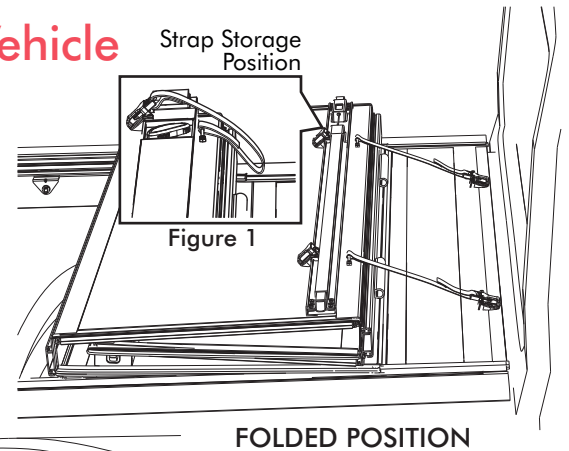

FOLDED & PROPPED UP TO CAB

Fold the cover open and lift it until it is vertical, or 90 degrees. Release the prop rods from the rail clips and engage the end of the prop rod with the ball fitting of the cover bracket. Always engage both sides.

Your cover should be firmly in position with little to no movement once the prop rods are locked.

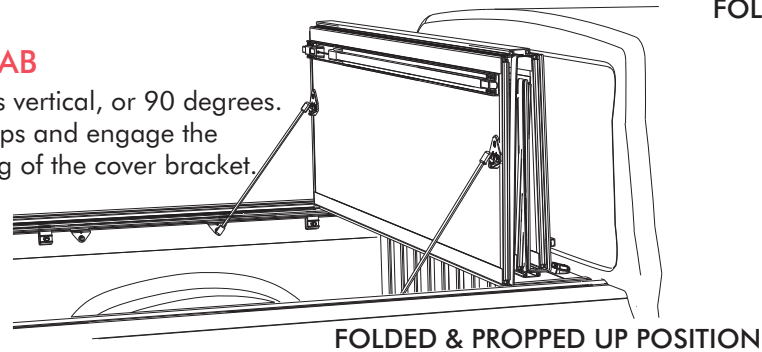

Tail Panel Operation

To close the tailgate panel

The tailgate can be closed with the cover either up or down.

To open the tailgate panel

Open the tailgate and reach under the driver's side of the tail panel for the rotary handle. Rotate the handle to release both latches, lift the panel to open.

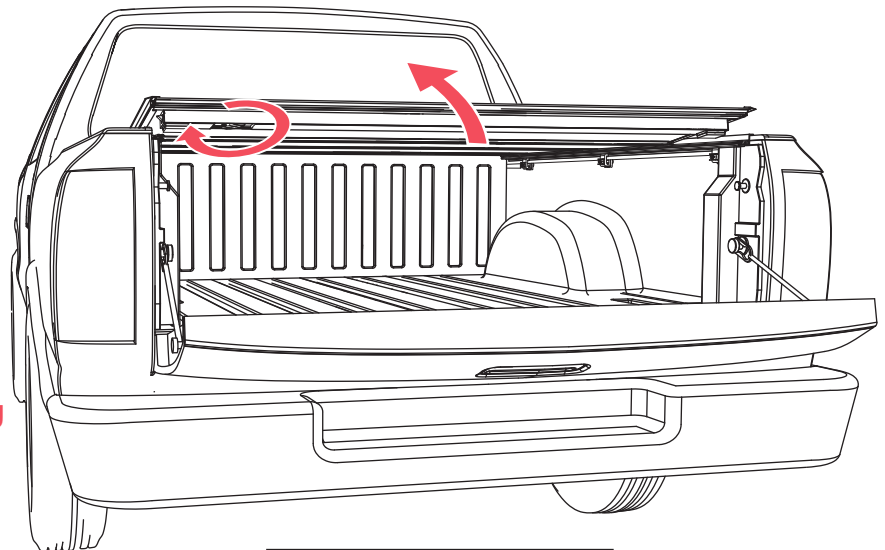

DO NOT DRIVE WITH THE TONNEAU IN A PARTIALLY OPEN POSITION!

Additional Important Operating Tips

- The bed cover MUST be free of foreign material including snow and ice before opening the panels.
- Do Not tow your vehicle from the rear with the bed cover in place.
- Do Not operate the vehicle with objects on top of the cover.



Remove any snow or foreign matter before folding the cover.



Do Not tow your vehicle from the rear with the cover on the truck.

FAILURE TO FOLLOW THESE CAUTIONS MAY RESULT IN SEVERE DAMAGE TO THE COVER AND WILL VOID YOUR WARRANTY!



Replacement Parts

NOTE: To order replacement parts, it is best to contact our Customer Service Department for assistance, to ensure getting the correct part for your vehicle application.

