

# INSTALLATION SHEET

# TRIFECTA<sup>ALX</sup>

**extang**  
truck bed covers

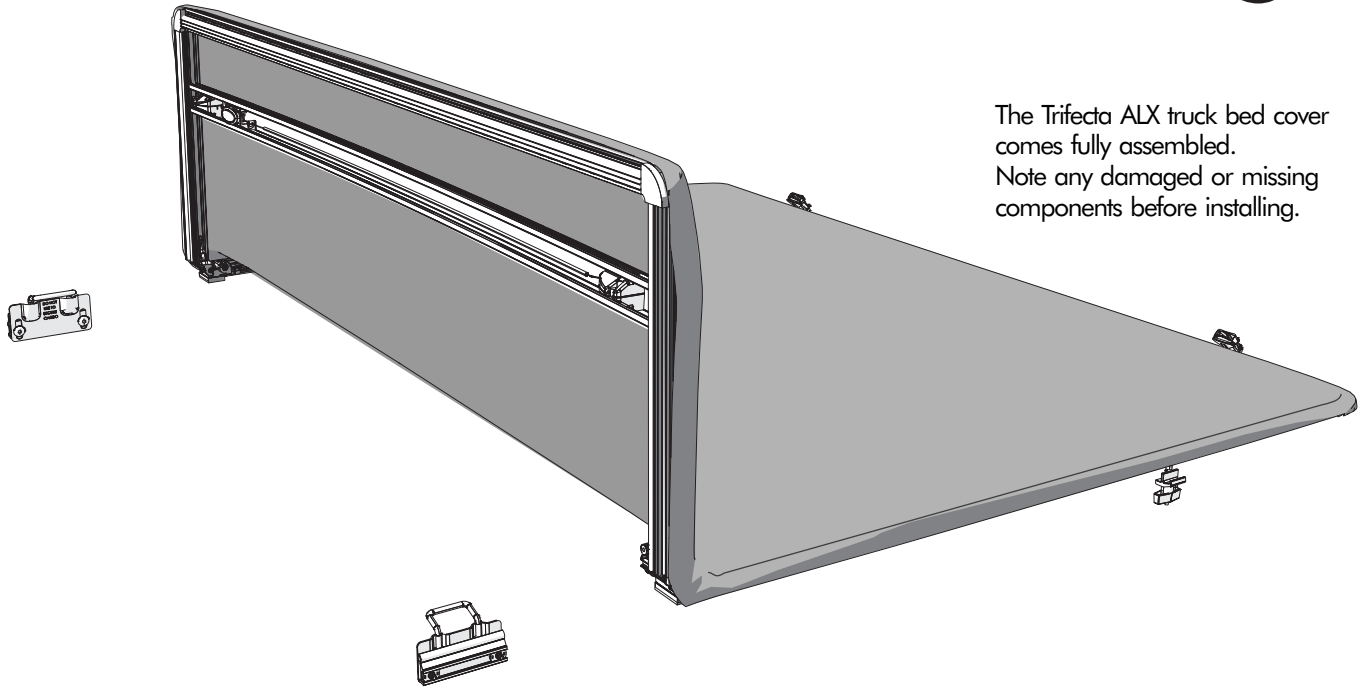

The Trifecta ALX truck bed cover comes fully assembled. Note any damaged or missing components before installing.

**Read through these instructions before installing, there are additional steps for different truck models**

**TOOLS PROVIDED: TOOLS REQUIRED: TOOLS FOR SPECIFIC INSTALLS:**

- Torx wrench - T-20
- Torx wrench - T-27
- Hex wrench - 2.5MM
- Knife or cutting tool
- Tape measure
- Pliers
- Socket or wrench- 1/2" (GM)

**1**

It is important that all areas where the bed cover mounts are clean and free of debris prior to installing.



**2**

Place the folded, assembled bed cover over the cab end of the truck box.

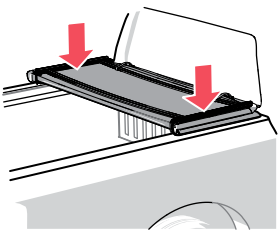

**3**

Unfold the bed cover fully and adjust position over the truck bed for proper front (cab) / rear (tailgate) alignment. When positioned front and back, the tailgate seal should contact the tailgate with the first two fins.

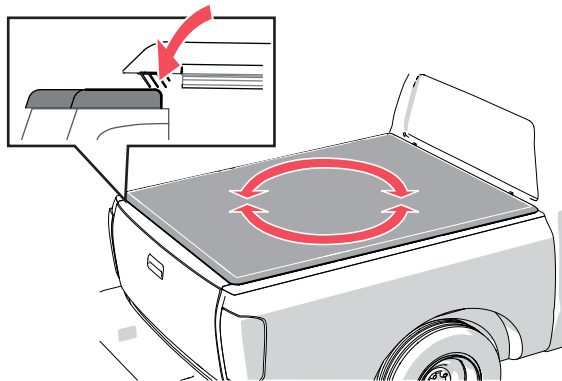

**4**

Carefully refold the bed cover without shifting its position on the truck bed. Note the position of the front clamp for trimming the bed cap in step 5.

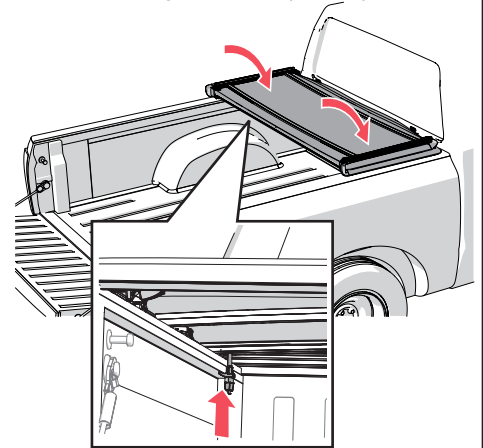

**5** **STOP** If your truck has a plastic bed rail cap that extends below the truck sheet metal bed flange, you **MUST** remove enough of the plastic so that the clamps make solid contact with the truck's sheet metal. This is commonly found on 04-14 & 21 Ford F150s and 09-19 RAMs, **but your specific vehicle should be inspected carefully to ensure a proper installation.**

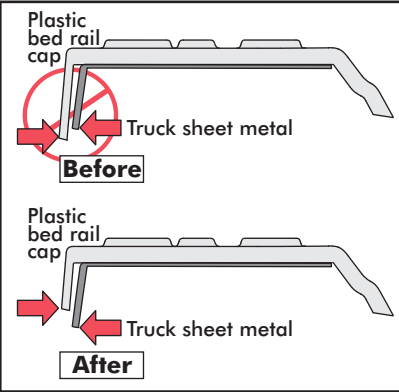

Measure and trim the plastic high enough to expose the truck sheet metal, and wide enough to accommodate the clamp.

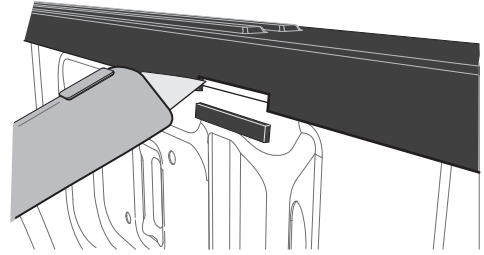

**Do not cut into or scrape the truck bed.**

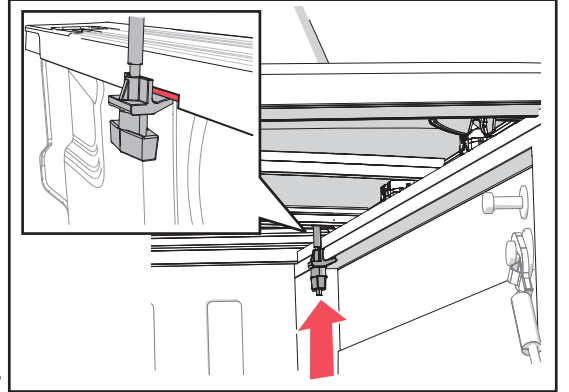

**6** Slide the cab clamps over to the truck bed rail. Hook the clamp jaw under the truck bed rail.

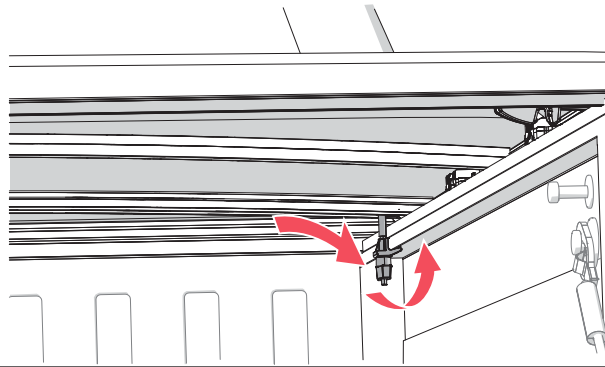

Hand tighten the clamps to hold the cover in position.

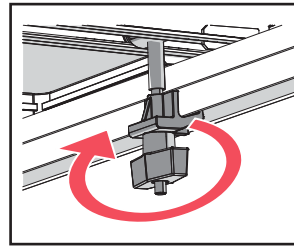

**7** With the tailgate open and the front (cab) clamps secure, completely close the bed cover.

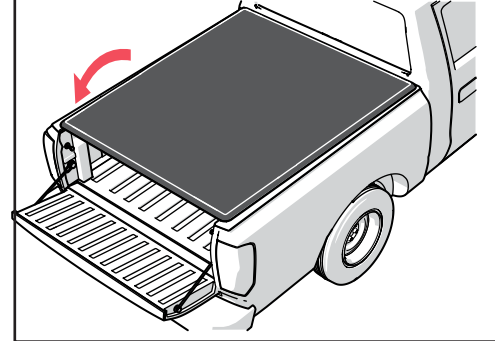

**8** The striker brackets are assemblies comprised of the bracket, Torx screws, a backing plate and nut plates.

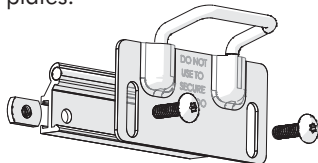

With the truck bed cover closed, attach the striker brackets to the metal truck bed rail.

Align the brackets so that the striker bracket loop aligns with, and firmly latches into cover latch assembly. (see step 9 for latch assembly adjustment). Attach both sides. Using the T-27 Torx wrench, tighten firmly to hold in place while continuing to align the latches in later steps.

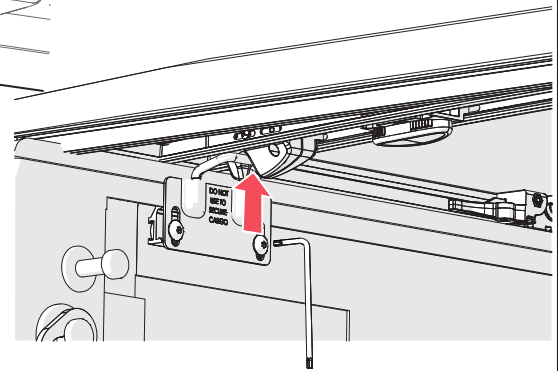
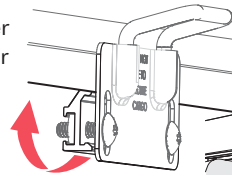

**8A** • Chevy/GMC Silverado/Sierra 1500 (5ft 8in, 6ft 6in) 2019-20, "New Body Style" (does not fit with factory side storage boxes) - DRIVER SIDE ONLY

If a drop-in bedliner is installed, clearance holes will need to be added to the bedliner to accept the striker bracket fasteners.

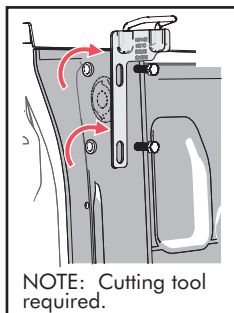

NOTE: Cutting tool required.

Truck beds **without** the MultiPro tailgate and assist handle.

Insert the nut plate down through the stake pocket opening and align with the 5/16" striker bracket bolts.

NOTE: A pair of pliers can help hold the nut plate when installing.

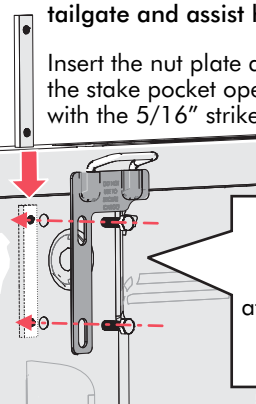

In both cases, the bolts or nuts will be tightened after the final bracket adjustment in step 11.

Truck beds **with** the MultiPro tailgate and assist handle.

Utilize the assist handle mounting studs and the original nuts to mount the striker bracket. After the final bracket adjustment in step 11, the nuts should be tightened to 30 Nm, 22 ft-lb.

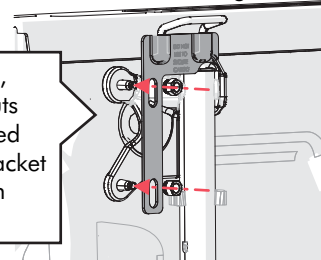

# 8B

- Chevy/GMC Canyon/Colorado (5ft & 6ft beds) 2015-20 - DRIVER AND PASSENGER SIDES
- Chevy/GMC Silverado/Sierra 1500 (5ft 8in, 6ft 6in) 2014-18, 2500/3500HD 2015-18
- Silverado 1500 Legacy & Sierra 1500 Limited 2019 - DRIVER AND PASSENGER SIDES
- Chevy/GMC Silverado/Sierra 1500 (5ft 8in, 6ft 6in) 2019-20, "New Body Style" (does not fit with factory side storage boxes) - PASSENGER SIDE ONLY

Insert the nut plate down through the stake pocket opening and align with the striker bracket washer and 5/16" bolt through the bed wall hole.

The bed wall hole plug will have to be removed

NOTE:  
A pair of pliers can help hold the nut plate when installing.

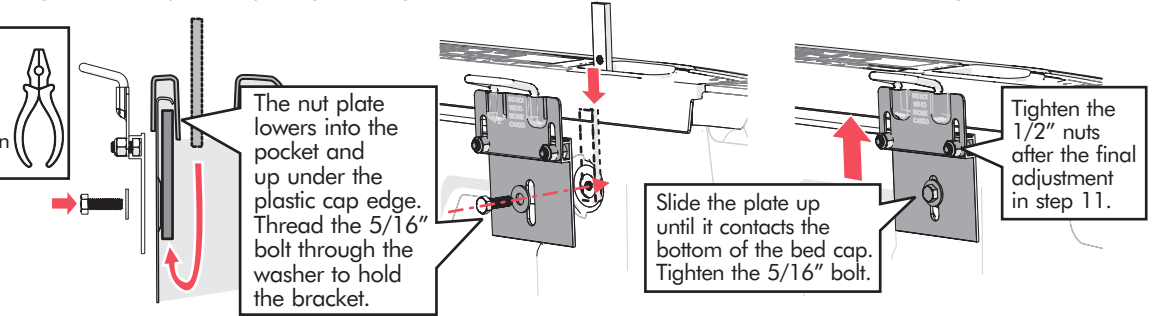

# 9

## Adjustments and tightening of the latch assembly is required.

The bed cover latch assembly comes from the factory *only partially tightened* to allow for installation adjustments. **Only use the hand tools provided, do not use power tools.**

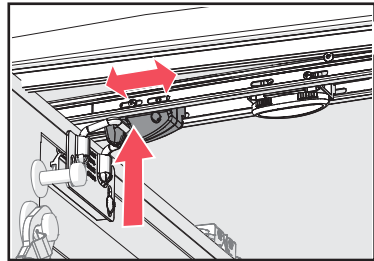

Lower the rear of the bed cover and adjust the position of each latch so that they engage with the striker brackets.

With the latches adjusted, use the provided T-20 Torx wrench to tighten the front screw in both the driver and passenger side latches and the actuator mechanism, shown below as 1, 2 & 3. Next, tighten the actuator mechanism set screws, (fig. 1) with the provided 2.5mm hex key to secure the latch cables. Rotate the actuator knob, (fig. 1) to verify that the latches disengage from the striker brackets.

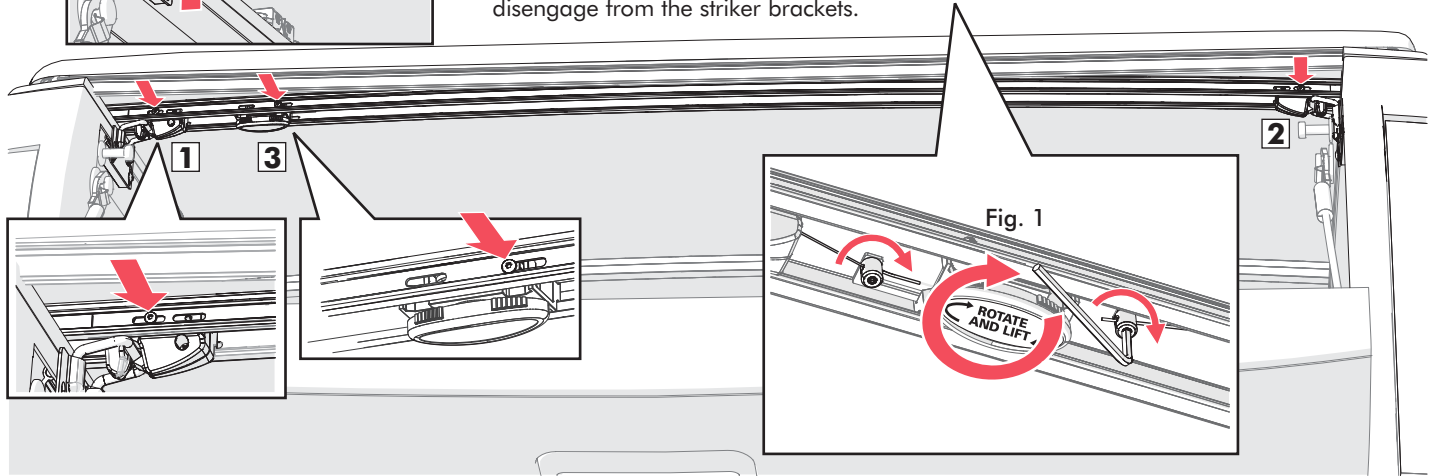

# 10

Fold the panel open and tighten the rear T-20 Torx screws in both the driver and passenger side latches and the actuator mechanism, shown below as 4, 5 & 6.

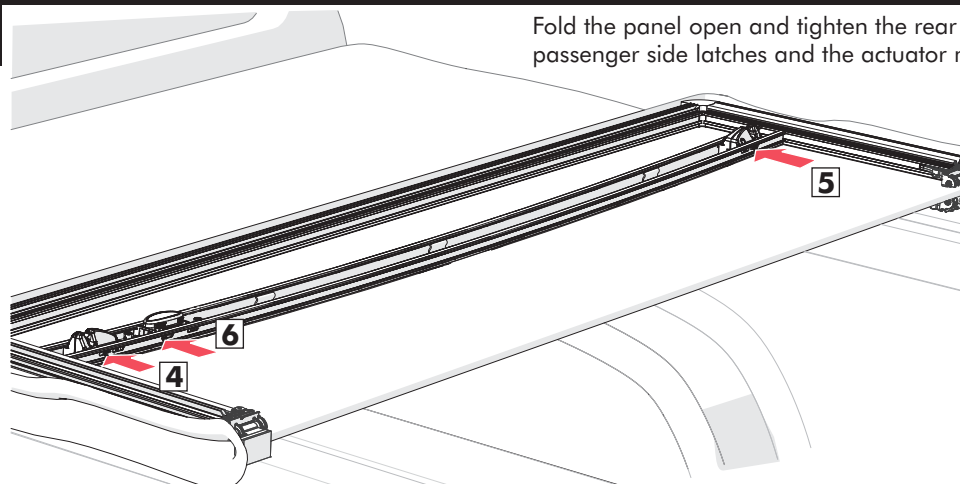

**11** To make the final adjustment, loosen the striker bracket screws. Then move the bracket down by firmly pulling the cover to the truck rail and tailgate. Make sure that both sides match, then retighten the screws.

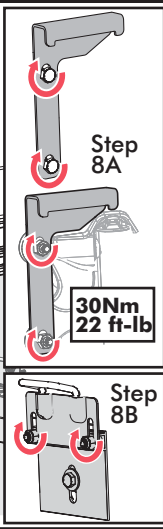
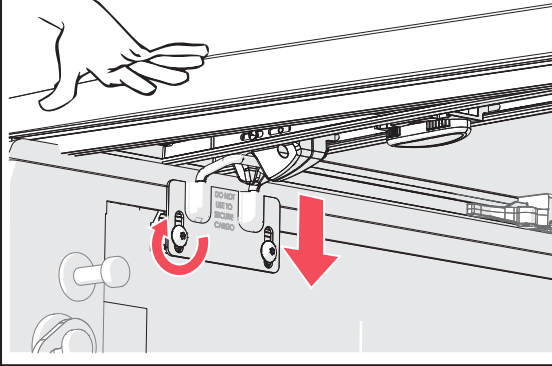

**12** The tethers come installed looped over the bed cover bow with a clamp at the other end. Install the clamp end by sliding the clamp onto the truck rail. Make sure the clamp is positioned as far up onto the rail as possible. Firmly hand tighten the knobs. Install the tethers on both sides of the cover.

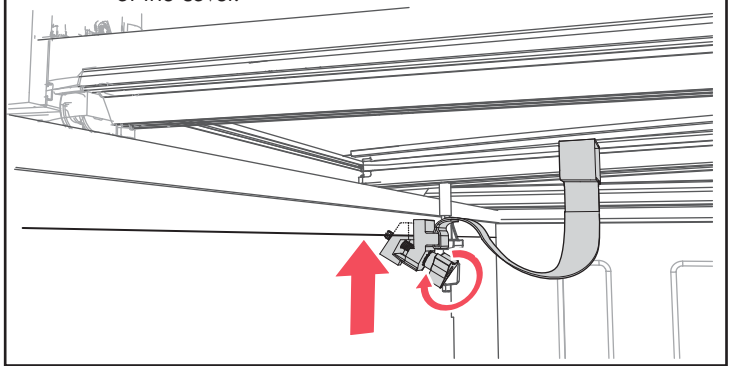

**Opening the cover.**  
Open the cover by twisting the actuator knob and lifting the cover.

**Securing the cover.**  
To drive with the cover open, fold the cover forward to the cab and fasten BOTH straps in the middle section to the front rail. Check that the straps are tight, and pull the strap end if too loose.

**IMPORTANT**  
Re-tighten the front (cab) clamps and tethers after the first week of driving the vehicle. Also periodically check the clamps and tethers to ensure they are secure.

Remove any snow or foreign matter before folding the cover

**IMPORTANT NOTICE**  
While driving, the cover must be completely flat and secure with all clamps and tethers installed and tight or completely folded up (all panels) and secured at the cab. **DO NOT DRIVE** with cover in partially opened position.

**Do NOT tow your vehicle from the rear with the bed cover on your truck**



NOTE: To order replacement parts, it's best to contact our Customer Service Department for assistance, to ensure getting the correct part for your vehicle application. When ordering, xxx represents the 3-digit suffix, as referenced on the sales receipt or vehicle application list.

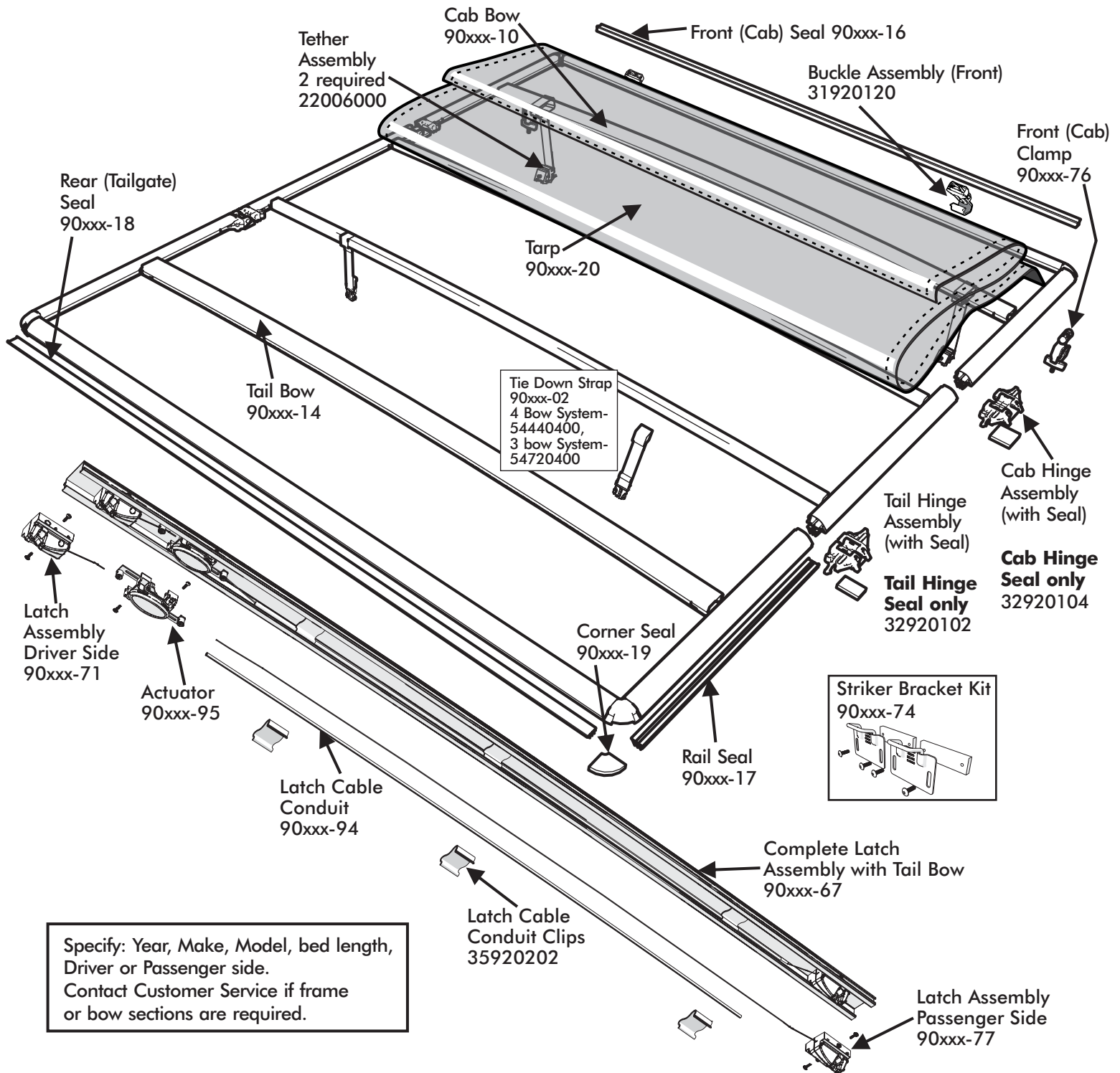

Specify: Year, Make, Model, bed length, Driver or Passenger side. Contact Customer Service if frame or bow sections are required.

