

INSTALLATION

TRIFECTA 2.0 Tool Box

extang
truck bed covers

The Trifecta 2.0 truck bed cover comes fully assembled.
Note any damaged or missing components before installing.

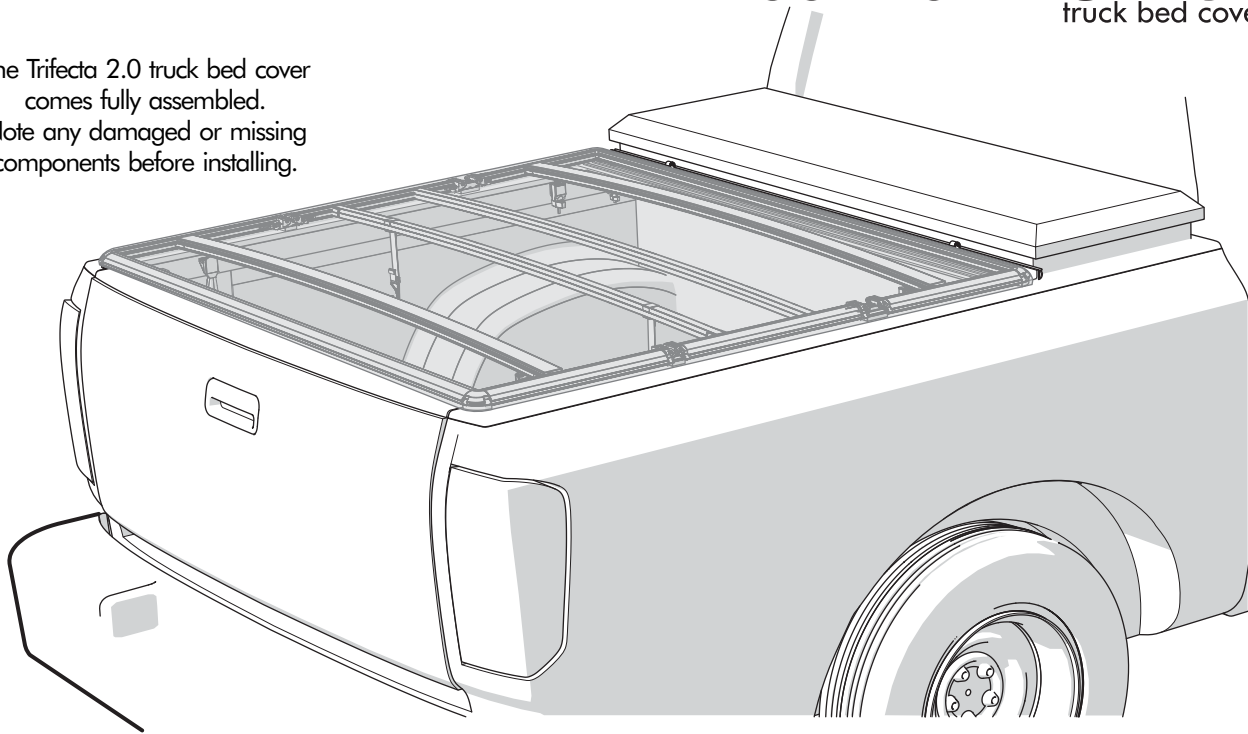

1 It is important that all areas where the bed cover mounts are clean and free of debris prior to installing.



2 Place L-channel against tool box with foam seal between the bottom of the L-channel and truck bed.

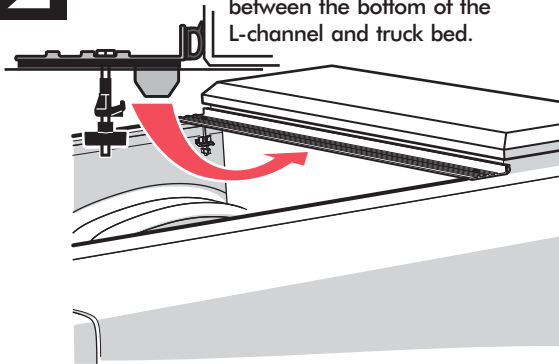

3 Ensure L-channel clamp is positioned under bed wall flange. Hand tighten until clamp contacts, then tighten an additional two turns.

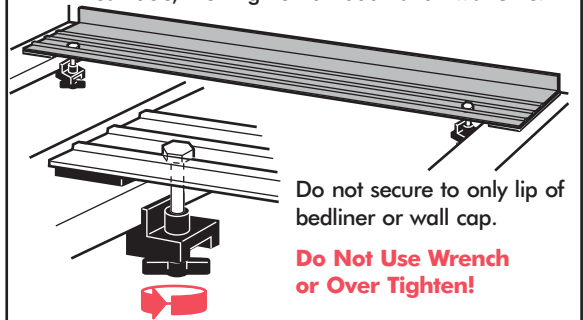

4 Place assembled cover front rail on top of the L-channel.

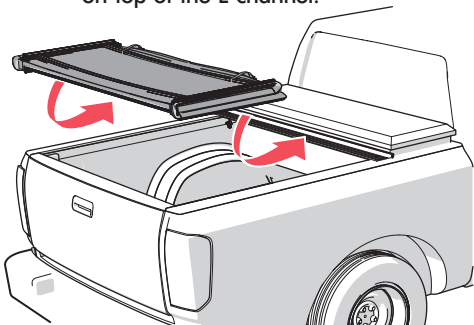

Center the cover side to side with the tool box. Unfold the cover fully and adjust position over the truck bed for proper front (cab)/rear (tailgate) alignment.

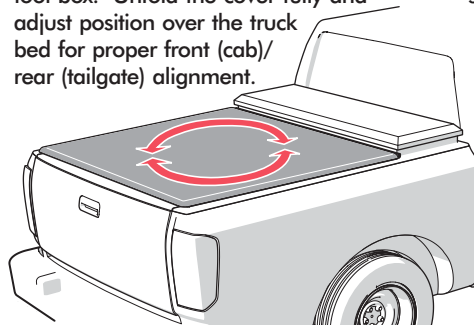

Carefully refold the cover without shifting its position on the truck bed.

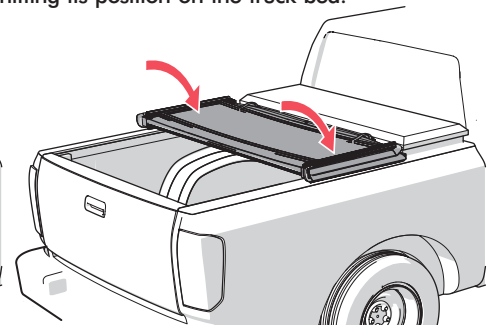

4

If your truck has a bed cap or bedliner that covers the metal bed wall flange, you will need to remove enough so that all the clamps make solid contact.

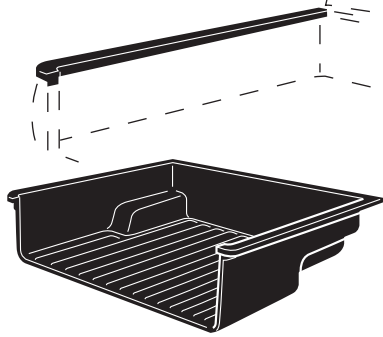

For bed caps, trim only enough of the bed cap edge so the rear (tailgate) clamp contacts the bottom of the metal flange.

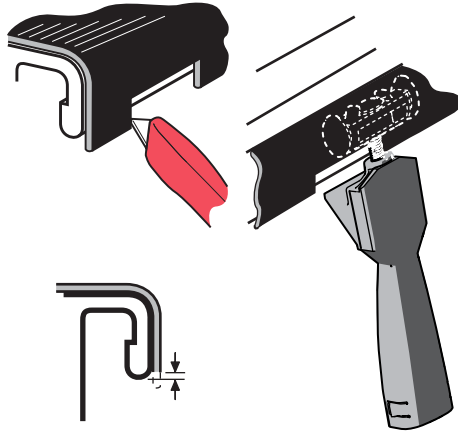

For bed liners that cover the metal flange, trim a minimum of 100 mm or 4" of the liner wall so the clamps contact the bottom of the metal flange.

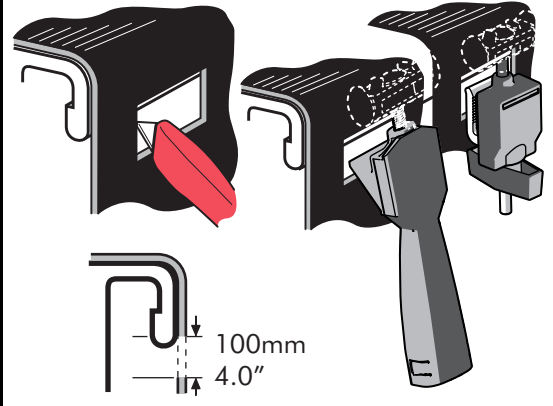

5

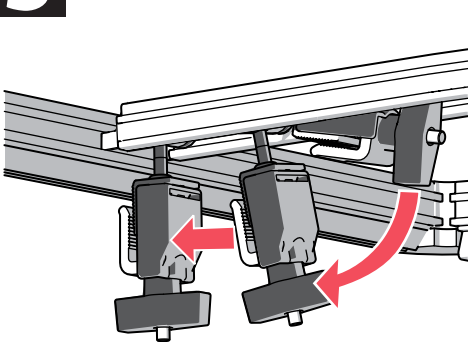

The front (cab) clamp stows in the cover rail. Rotate the clamp down and slide it at an angle towards the bed rail.

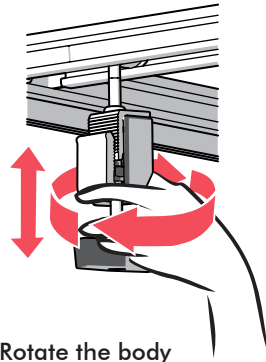

Rotate the body of the clamp up or down to match its position with the bed rail flange.

Position the clamp body so that the bottom ridges match the bottom of the metal flange.

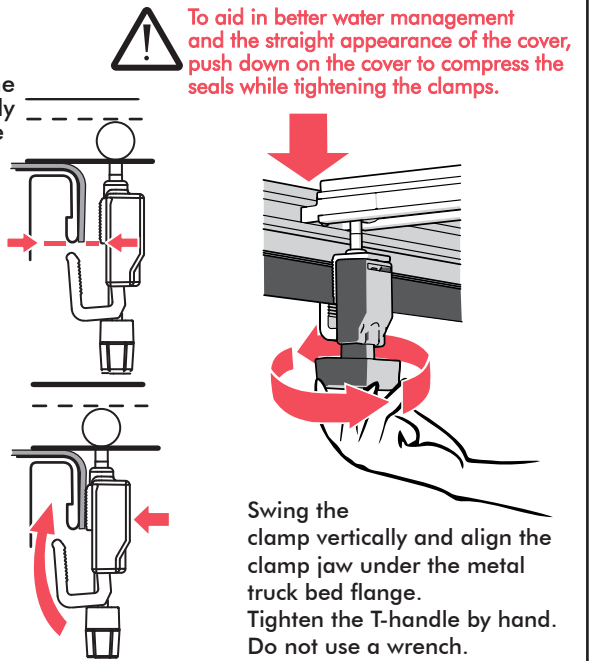

To aid in better water management and the straight appearance of the cover, push down on the cover to compress the seals while tightening the clamps.

Swing the clamp vertically and align the clamp jaw under the metal truck bed flange. Tighten the T-handle by hand. Do not use a wrench.

6

With the tailgate open and the front (cab) clamps secure, completely close the cover.

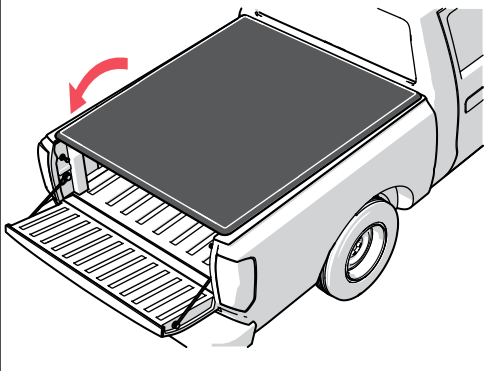

7

The rear (tailgate) clamps are stowed in the cover rail, rotate the clamp down and slide it at an angle to the truck bed rail.

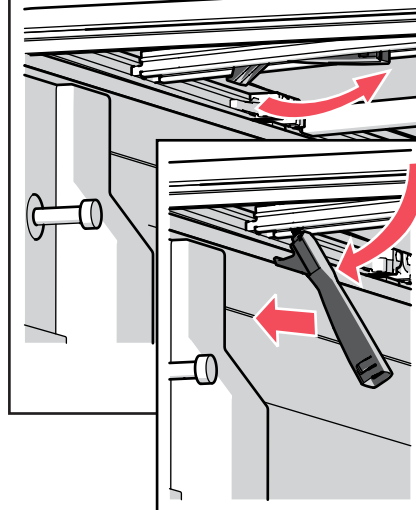

The clamps should be slid as far over to the rail as possible.

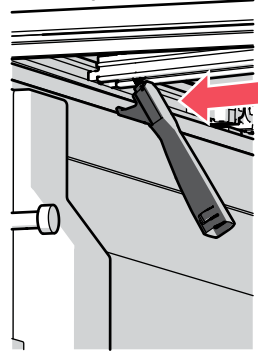

To lock the cover, pull the clamps straight down and release to hook under the bottom of the bed rail.

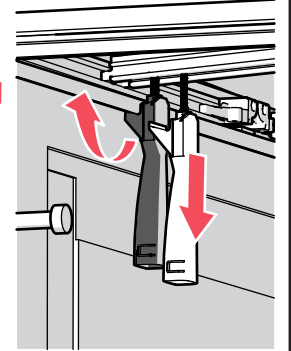

8

To prepare the Trifecta 2.0 to drive in the open position, release the rear (tailgate) clamps and fold the cover forward.

IMPORTANT: Before folding the second section of the cover the rear (tailgate) clamps must be stowed securely into the rail.

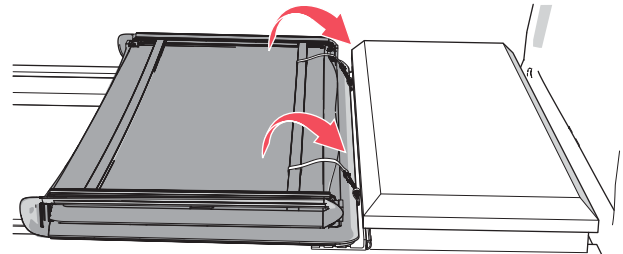
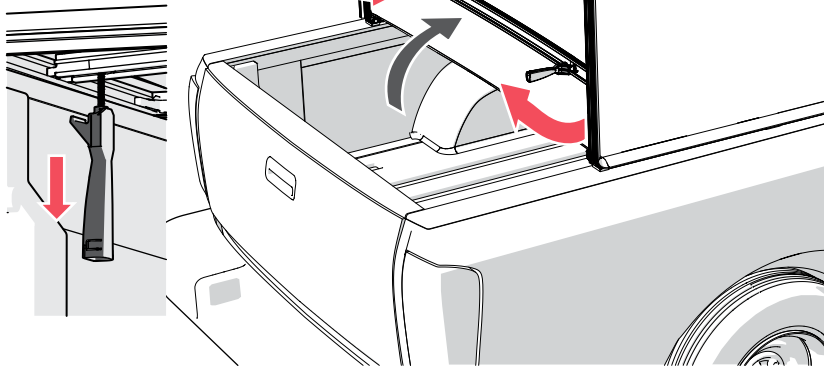

Fold the cover forward and fasten BOTH straps in the middle section to the front rail.

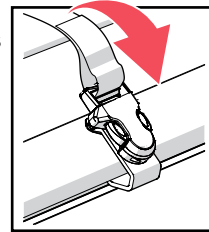

Special Instructions for Alternative Brackets

Nissan Frontier 2005-

Front (cab clamp)

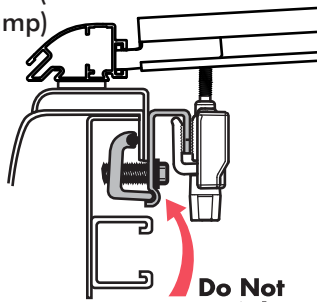

Do Not Overtighten

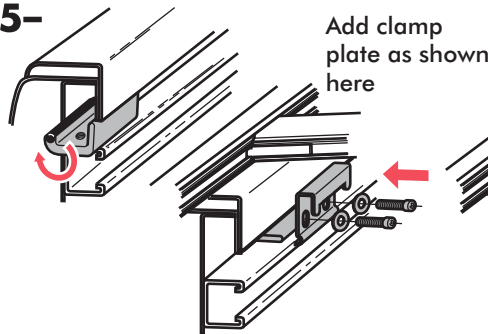

Add clamp plate as shown here

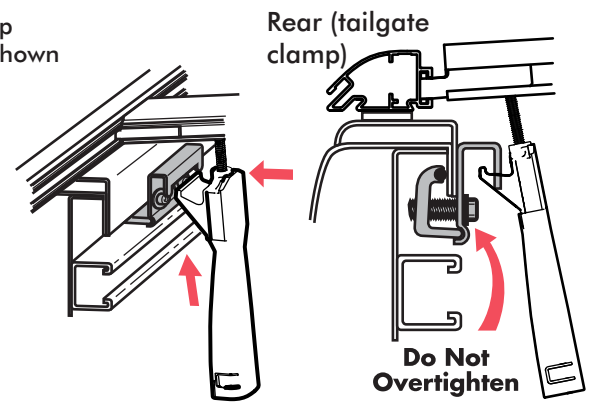

Rear (tailgate clamp)

Do Not Overtighten

All other Cargo Management equipped trucks

Front (cab clamp)

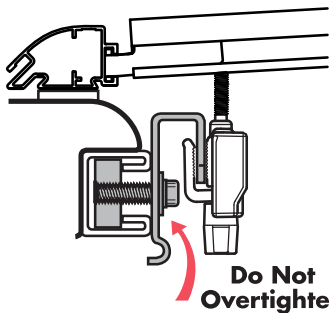

Do Not Overtighten

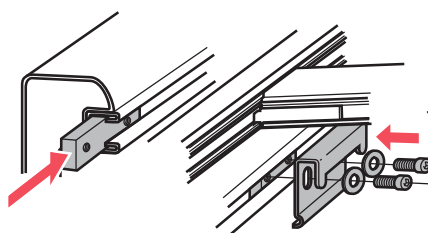

Add clamp plate as shown here

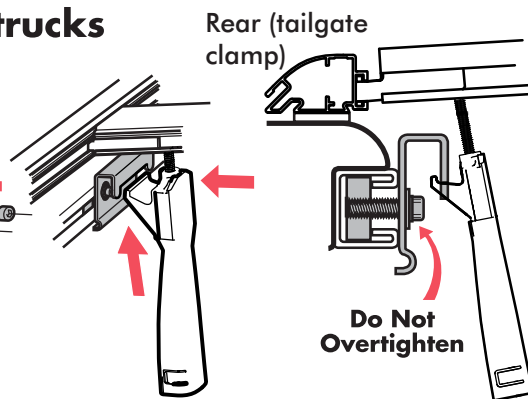

Rear (tailgate clamp)

Do Not Overtighten



IMPORTANT

Re-tighten the front / cab clamps after the first week of driving the vehicle. Also periodically check the clamps to ensure they are secure.

Remove any snow or foreign matter before folding



IMPORTANT NOTICE

While driving, the cover must be completely flat and secure with all four clamps in the closed position or completely folded up (all panels) and secured at the cab. DO NOT DRIVE with the cover in a partially open position.

Do NOT tow your vehicle from the rear with any Extang bed cover on your truck



TRIFECTA 2.0 Tool Box

Replacement Parts

NOTE: To order replacement parts, it's best to contact our Customer Service Department for assistance, to ensure getting the correct part for your vehicle application. When ordering, xxx represents the 3-digit suffix, as referenced on the sales receipt or vehicle application list.

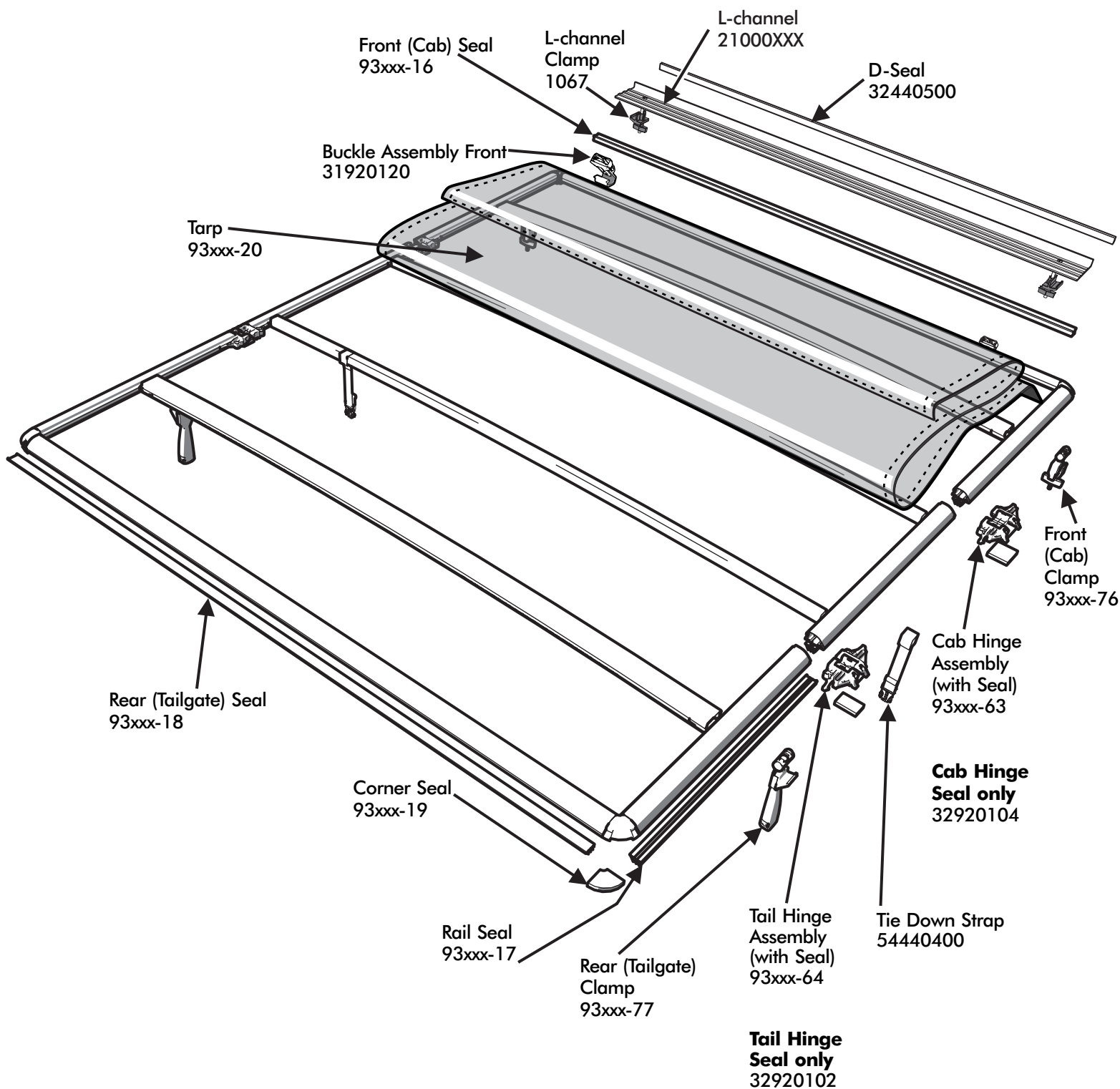

Specify: Year, Make, Model, bed length, Driver or Passenger side.
Call Customer Service if frame or bow sections are required.