

TRIFECTA E-SERIES INSTALLATION SHEET

NO TOOLS REQUIRED

NOTE: It is important that all areas where the bed cover mounts are clean and free of debris prior to installing.

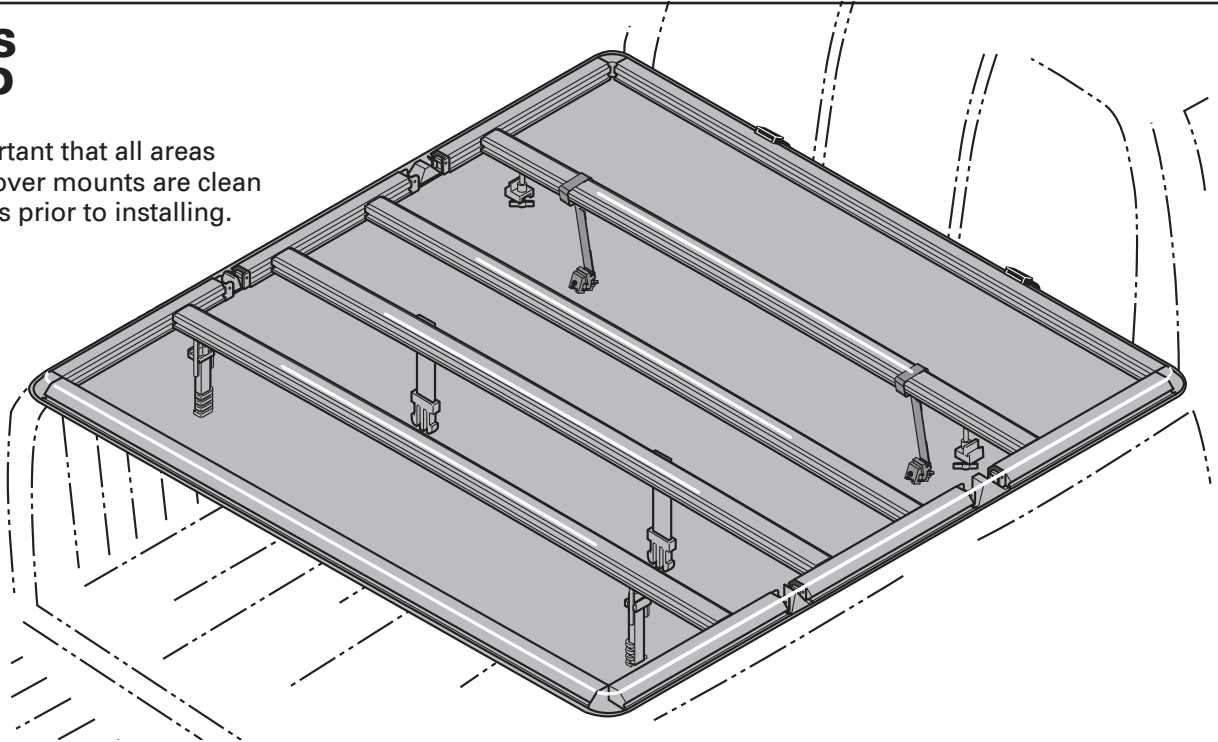

1

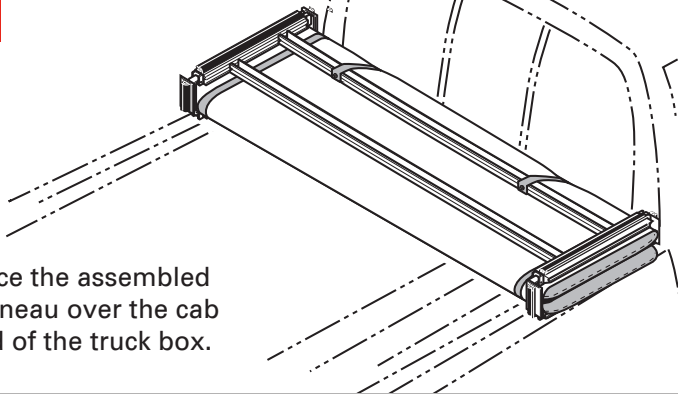

Place the assembled tonneau over the cab end of the truck box.

2

Unfold the tonneau fully and adjust the position over the truck bed for proper cab and tail alignment.

Then carefully refold the tonneau without shifting its position on the truck bed.

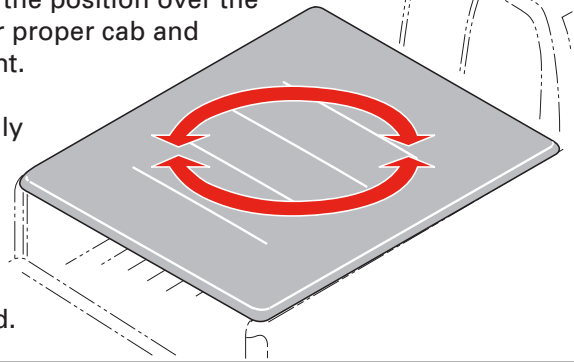

3

STOP

If your truck has a plastic bed rail cap that extends below the truck sheet metal bed flange, you **MUST** remove enough of the plastic so that the clamps make solid contact with the truck's sheet metal.

This is commonly found on 04-14 & 21 Ford F150s and 09-19 RAMs, but your specific vehicle should be inspected carefully to ensure a proper installation.

BEFORE



AFTER

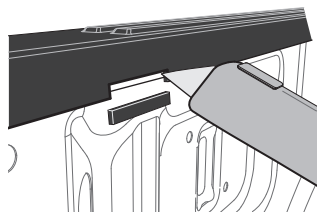
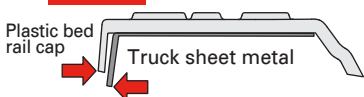

Trim the plastic high enough to expose the truck metal, and wide enough to accommodate the clamp.

Do NOT cut into or scrape the truck bed.

Tail clamp

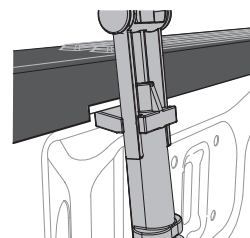

Cab clamp

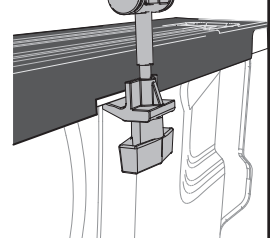

4 Ensure that the clamp is positioned under the metal bed flange. Hand tighten until clamp contacts the flange, then tighten an additional two turns. Do Not secure to only the lip of the bedliner or wall cap. **Do Not Use a Wrench or Overtighten!**

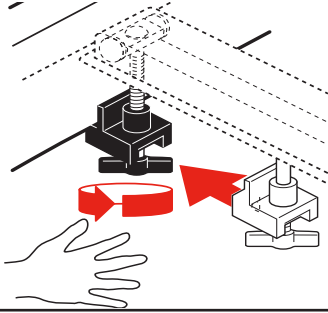

5 With the tailgate open, completely close the tonneau.

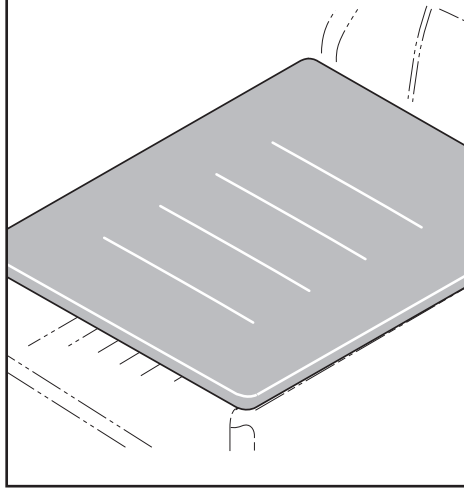

6 Slide the rear clamp out to the bed wall. Pull the rear clamp down, and hook it under the bottom edge of the metal bed flange.

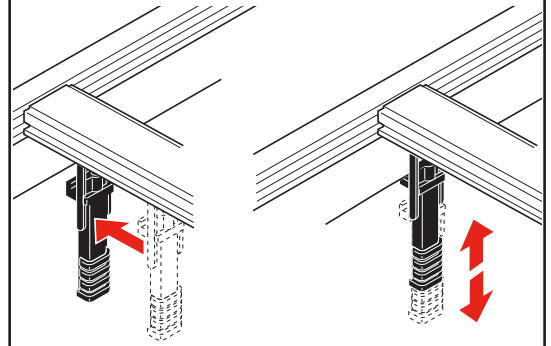

7A Truck beds with metal flanges (without cargo rails)

Open the cover. The tethers are attached to the cover bow. Attach the clamp to the metal flange of the truck bed rail and tighten the knob. Do this for both the driver and passenger side.

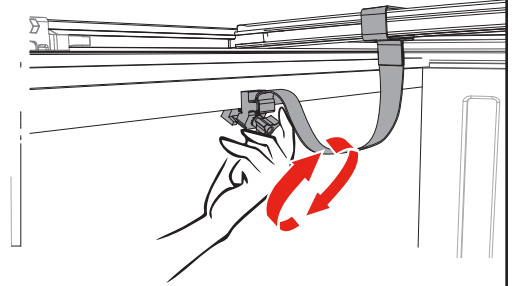
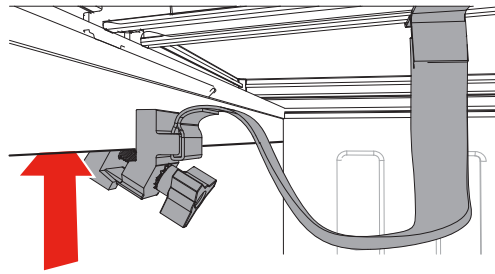
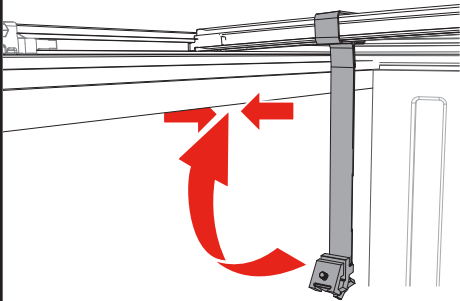

7B Truck beds with factory cargo rails

Open the cover.

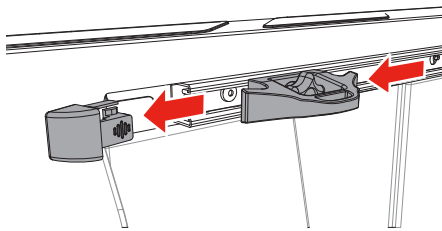

Remove the cargo rail end cap and any tie-down cleats.

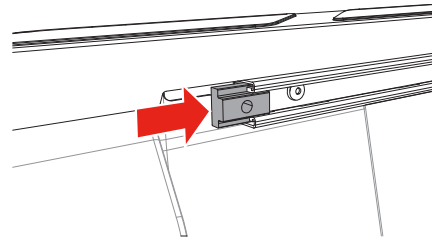

Insert the provided slide block into the cargo rail.

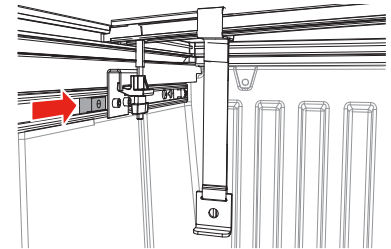

Move the slide block forward to the front bow of the cover.

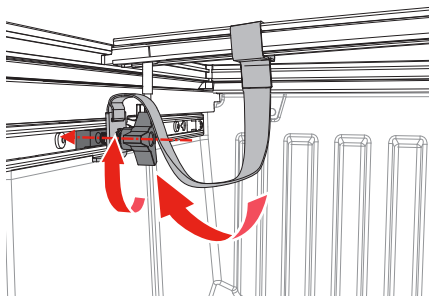

Thread the tether knob through the lock washer, through the tether bracket and into the slide block.

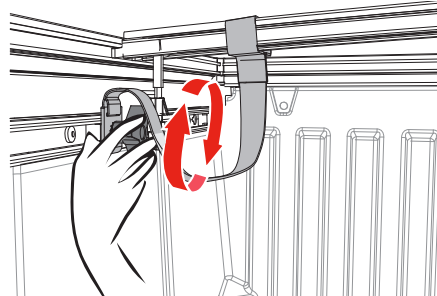

Tighten the knob. Do these steps for both the driver and passenger sides.

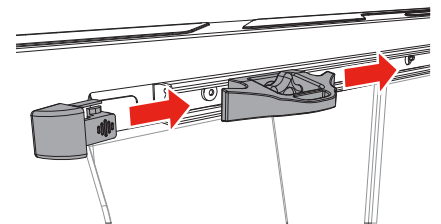

Reinstall any tie-down cleats and the end cap on both sides of the truck.

DRIVING WITH THE TONNEAU OPEN

Release the rear clamps and fold the tonneau forward.

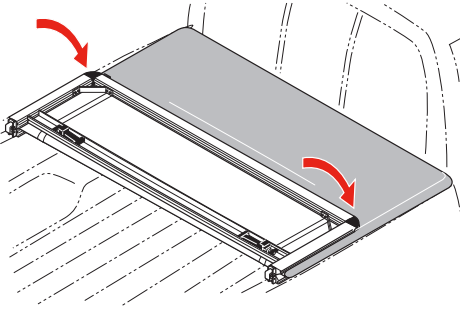

IMPORTANT: Before folding the second section of the tonneau, the rear clamps must be stowed into the rail to prevent damage to the fabric. **Failure to stow the handle will puncture the tarp and void the warranty.**

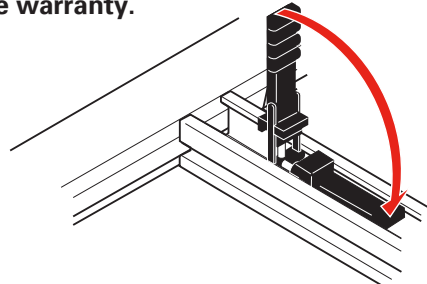

Fold the tonneau forward and fasten the straps in the middle section to the front rail. Check that the straps are tight.

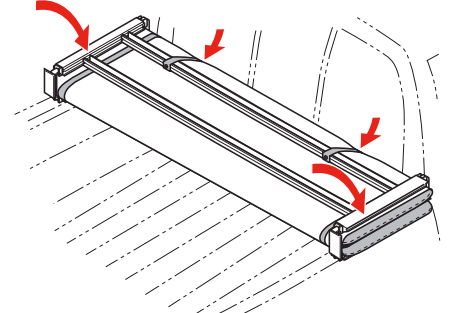

IMPORTANT

Re-tighten the front/cab clamps and tethers after the first week of driving the vehicle. Also periodically check the clamps and tethers to ensure they are secure.

Closed/Extended Position – Bed cover must be completely secured by all four (4) clamps.
Open/Folded Position – Bed cover must be completely folded up (all panels) and secured at the cab with the provided buckles straps and with both tethers attached.

Do NOT drive with the bed cover in a partially open position.

NOTE: the tarp cannot be removed from the aluminum frame. Attempting to do so will cause damage and void the warranty.

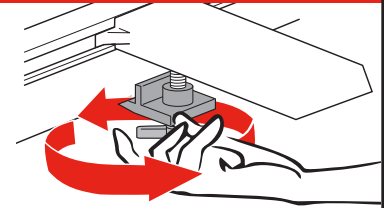

Do NOT allow the vehicle to be towed backwards without first removing the cover from the vehicle.



Remove any snow or foreign matter before folding the bed cover.

CARGO MANAGEMENT EQUIPPED TRUCKS BRACKET KIT INSTALLATION

Cab Clamp

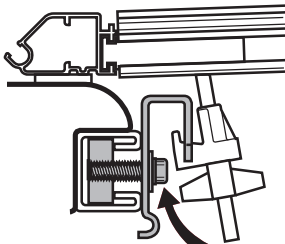

Do Not Overtighten

Add the clamp plate, washers and screws as shown.

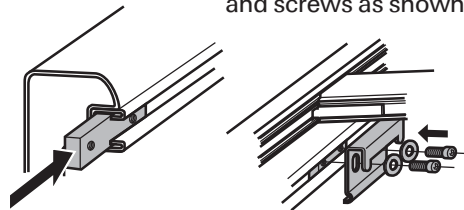

Tailgate Clamp

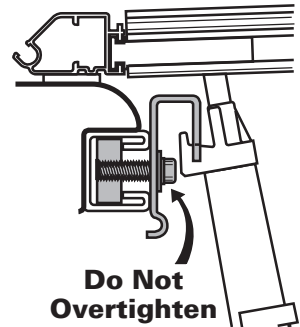

Do Not Overtighten

REPLACEMENT PARTS

NOTE: To order replacement parts, it is best to contact our Customer Service Department for assistance to ensure that you get the correct part for your vehicle application. When ordering, xxx represents the 3 digit suffix, as referenced on the sales receipt or vehicle application list.

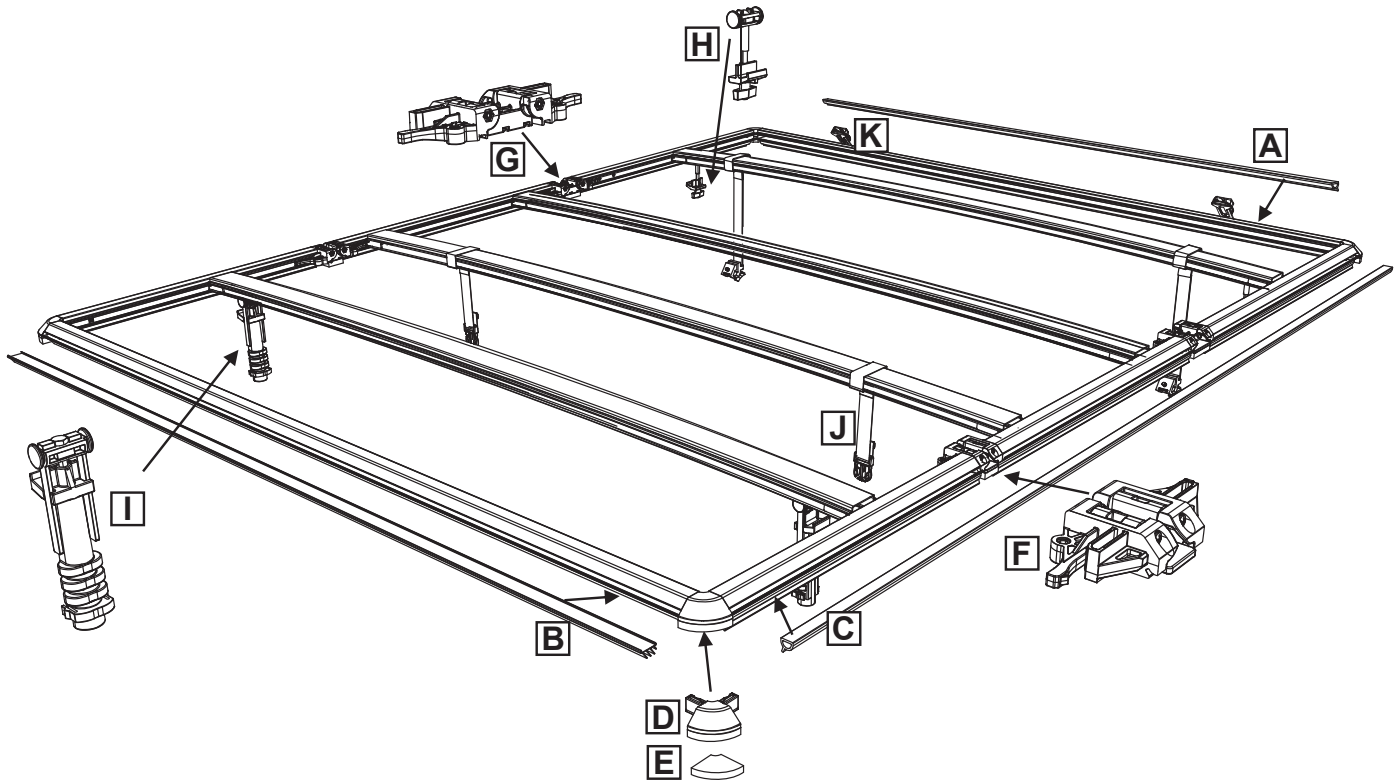

Call Out	Title	Part Number	Description	Model Year	Qty
A	Cab Seal	32440500	1/2" D Seal (6') fits most applications		1
A	Cab Seal	32562569	3/4" Two-fin Seal (69.5") fits Nissan Frontier applications	2005-2020	1
A	Cab Seal	32562569	3/4" Two-fin Seal (69.5") fits Chevy Siverado/GMC applications	2019-2020	1
A	Cab Seal	32001668	1 3/8" Foam Seal (5'5") fits Toyota Tacoma applications	2005-2015	1
A	Cab Seal	32270600	Honda Ridgeline	2006-2020	1
B	Tail Seal	32001768	Standard Tail Fin Seal (68") fits all trucks except Toyota Tacoma		1
B	Tail Seal	32001668	1 3/8" Foam Seal (5'5") fits Toyota Tacoma applications	2005-2015	1
C	Side Seal	32520052-0	Bulb Seal (8')		1
D	Corner with Pad	4211	Corner with pad, used front or rear		2
E	Corner Pad	4210	Pads only, used front or rear		2
F	Rear Hinge Assembly	1033			1
G	Front Hinge Assembly	1032			1
H	Front Clamp Assembly	1034			1
I	Rear Clamp Assembly	1035/1042			1
J	Tarp Tie Down Strap	54440400			1
K	Buckle Assembly	54440100	For Tie-down Strap		1