

**EVOCHARGE**<sup>™</sup>

# EVOCHARGE<sup>®</sup> WITH EVOREEL<sup>®</sup> Charging Stations (EVSE, iEVSE, iEVSE Plus)

---

Installation Guide & User Manual

Revision 1.3



# IMPORTANT SAFETY INSTRUCTIONS

This document contains instructions and warnings that must be followed when installing and using the Electric Vehicle Supply Equipment (EVSE). Before installing or using the EVSE, read this entire document as well as WARNING and CAUTION markings in this document.

## Safety Instructions

The symbols used have the following meaning:

---



WARNING: RISK OF PERSONAL INJURY



WARNING: RISK OF ELECTRIC SHOCK



WARNING: RISK OF FIRE



CAUTION: RISK OF DAMAGE TO THE EQUIPMENT

---

- The charging station must be installed, adjusted, and repaired only by a licensed electrician.
- Make sure that the materials used and the installation procedures follow local building codes and safety standards.
- The information provided in this manual in no way exempts the user of responsibility to follow all applicable codes or safety standards.
- This document provides instructions for the charging station and should not be used for any other product. Before installation or use of this product, review this manual carefully and consult with a licensed contractor, licensed electrician, or trained installation expert to make sure of compliance with local building codes and safety standards.
-  CAUTION: To reduce the risk of fire, connect only to a circuit provided with the minimum branch circuit overcurrent protection requirements in accordance with the National Electrical Code, ANSI/NFPA 70, and the Canadian Electrical Code, Part I, C22.1.

## Repair and Maintenance Clause

- All EVOCHARGE products do not require routine maintenance however, periodic inspections should be conducted to ensure that all parts remain in good working order and no damage exists. Do not attempt to open, disassemble, repair, tamper with, or modify any components of the products – the products are not user serviceable. Contact EVOCHARGE for any repairs.
- Only licensed electricians can repair or maintain the charging station. It is forbidden for general users to repair or maintain it. Turn off input power before performing any repairs or maintenance to the charging station.

## FCC Declaration of Conformity

- This charging station complies with part 15 of the FCC Rules. Changes or modifications the charging station not expressly approved by the manufacturer could void FCC compliance.
- Operation is subject to the following two conditions: (1) This charging station may not cause harmful interference, and (2) this device must accept any interference received, including interference that may cause undesired operation.

## OVERALL WARNINGS & CAUTIONS

### WARNING: RISK OF ELECTRIC SHOCK



Basic precautions should always be followed when using electrical products, including the following:

- Read all the instructions before using this product.
- This device should be supervised when used around children.
- Do not put fingers into the EV connector.
- Do not use this product if the flexible power cord or EV cable is frayed, has broken insulation, or any other signs of damage.
- Do not use this product if the enclosure or the EV connector is broken, cracked, open, or shows any other indication of damage.



### WARNING: RISK OF ELECTRIC SHOCK

Improper connection of the equipment grounding conductor can result in a risk of electric shock. Check with a qualified electrician or serviceman if you are in doubt as to whether the product is properly grounded.



### WARNING: RISK OF ELECTRIC SHOCK

- Do not touch live electrical parts.
- Incorrect connections may cause electric shock.

WARNING: This equipment is intended only for charging vehicles that do not require ventilation during charging. Please refer to your vehicle's owner's manual to determine ventilation requirements.

# Product Features

## EVOCHARGE® With EVOREEL® Electric Vehicle Charging Stations

- J1772 AC Level 2 (208-240 VAC), 24A (5.8 kW) Continuous Output Rated (Per Port) with adjustable Maximum Current Output capability to Support Multiple Circuit Ratings
- EVOREEL® with EVOCHARGE Charging Stations:
  - EVOCHARGE EVSE: Standard charging station, non-networked
  - EVOCHARGE iEVSE: True Open Protocol: OCPP 1.6 capable of operating on any OCPP network
  - EVOCHARGE iEVSE® Plus: Access Control via RFID Card (Including without Network Connection) & Mobile App; Payment Capability; Remote Monitoring/Control; Demand Response & Local Load Management
- EVOREEL® with EVOCHARGE EVSE:
  - Simple Operation: No user interface required with EVSE, simply Plug-in to your EV to initiate charging
- Modern, Elegant & Compact Design: EVSE form factor smaller than a standard sheet of letter-size paper
- Robust Construction, Certified for Outdoor Use: Robust, durable design; tamper-resistant features including provision to install a padlock to secure charging station to mount; NEMA 4 certified for outdoor and indoor use
- Cable & Connector Management: EVOREEL Cable Management with Connector Holder
- Charging Station: UL & cUL Listed, File Number: E469990

## Security and Tamper Feature

In addition to the lock screw that secures the EVOCHARGE iEVSE Plug charging station to the wall mount bracket (Refer to Section 2.3, Note 3., Installing the Charging Station), if desired, a feature is included as part of the charging station and wall mount bracket to install a small padlock for added security and tamper benefits. This feature is located at the bottom of the charging station near the charging station – wall bracket lock screw.

## Self-Monitoring and Recovery | Power Outage Recovery

When a charging session is interrupted due to a temporary error condition, the charging station will automatically restart charging when the cause of the temporary error condition returns to normal. The status indicator lights remain flashing RED until the error condition is resolved.

- Temporary error conditions include: Over Current, Over Voltage, Under Voltage, and Over Temperature.
- For Over Current (OC) conditions: The charging session will be stop while OC occurs. After recovery from OC for 30 seconds, the charging station will automatically restart charging for three times.
- When charging session stopped due to CCID trip, the charging station will try to restart after 15 minutes for 3 times.

When power resumes after an outage, the charging station restarts automatically with a delay ranging from 120 to 720 seconds. The delay is designed to avoid impacting the utility grid when multiple charging stations are in the same area attempting to resume charging simultaneously.

# Product Specifications

## EVOCHARGE® With EVOREEL® Electric Vehicle Charging Stations

Description	Specifications
EVSE Type	SAE J1772; AC Level 2  EVOCHARGE EVSE: Standard, Non-network EV Charging Station EVOCHARGE iEVSE: Intelligent, Open Network, OCPP-enabled charging station EVOCHARGE iEVSE Plus: OCPP 1.6 via LTE Cellular Modem, Wi-Fi or Ethernet connection
Max Output Rating	24A, 5.8 kW Maximum Output For use with a 40A (or greater) Dedicated Circuit
Alternate Adjustable Output Ratings	16A or 24A for use with 20A or 30A Dedicated Circuit
Charge Cable Lengths	Standard: 22 ft. (6.7m); Optional: 30 ft. (9.1m)
Electrical Circuit / Input Power Requirements	208-240VAC, 50/60 Hz. Circuit Requirement: 40A (or greater) Dedicated Circuit Per Port; Branch Breaker: Double pole; Circuit Conductors: Line 1, Line 2, Earth Ground
Input Power Connection	P/N: EVO30-111-002: Hardwire, 1" NPT Knockout at Bottom of EVSE P/N: EVO30-101-002: NEMA 6-50P Plug-in (can be removed for Hardwire)
Charging Station Color	Standard: White
Installation Rating	NEMA 4, Indoor/Outdoor Rated
Operational Ratings	Temperature: -22°F to 122°F (-30°C to 50°C); Humidity: 95% RH non-condensing
Mounting	Wall or Ceiling Mount Installation
Overall Dimensions (HxWxD)	EVSE: 11.0 x 7.5 x 3.2 inches (28.0 x 19.0 x 8.1 cm) EVOREEL: 13.8 x 12.0 x 9.2 inches (35.1 x 30.5 x 23.3 cm)
Display & Indicators	LED Charge Status Indicators (Power/Ready, Charging, Fault) & LED Display
Cable Management	EVOREEL Cable Management with Connector Holder
Standards & Compliance	EVSE: UL & cUL Listed, File Number: E469990; SAE J1772, UL 2594, UL 355, CSA

# SAVE THESE INSTRUCTIONS

## Manual Contents

1	Introduction & Unpacking.....	7
1.1	Unpacking .....	7
2	Installation .....	8
2.1	Before Installation.....	8
2.1.1	Installation Planning & Service Wiring.....	8
2.1.2	Grounding Instructions .....	8
2.2	Tools & Parts Required for Installation.....	9
2.3	Input Wiring Connection (Optional for p/n: EVO30-101-002).....	9
2.4	Installation Steps.....	9
2.5	Install the Plug and Cable Holder.....	14
2.6	Charging Status Indicators .....	16
2.7	Charging your Electric Vehicle (EV).....	16
2.7.1	Plug and Charge .....	17
2.7.2	Online Authorization .....	17
2.7.3	RFID Card Authorization Local and Offline Authorization.....	17
2.8	Stop Charging .....	18
2.8.1	Self-Monitoring and Recovery (Auto Restart).....	18
2.8.2	Power Outage Recovery.....	19
2.9	General Product Care and Use Information .....	19

# 1 Introduction & Unpacking

This user manual applies to the EVOREEL® Charging Stations for use with all Electric Vehicles (EVs) and Plug-in Hybrid Electric Vehicles (PHEVs) sold in North America.

## 1.1 Unpacking

Unpackage all items and confirm the contents as noted below.

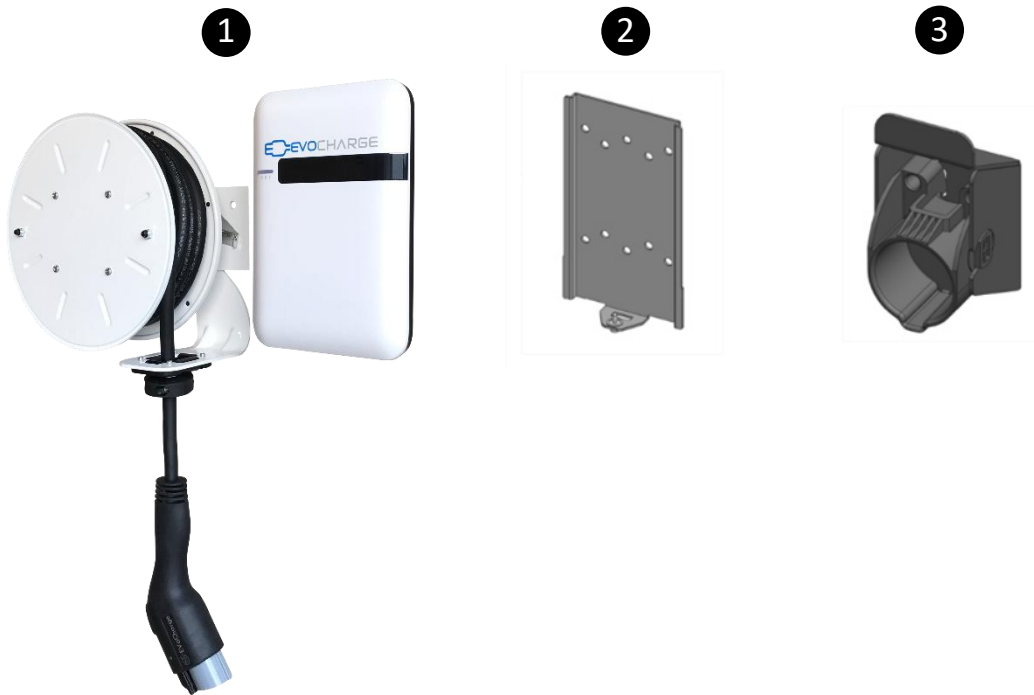

Figure 1-1 Box Contents

Table 1-1 Box Contents

Item	Description	Qty.	Notes
1	Charging Station with EVOREEL Cable Management System	1	
2	Charging Station Mounting Bracket	1	Bracket is Attached to each Charging Station
3	Connector Holder	1	Holder is packaged within cardboard compartment of charging station packaging
4	Mounting Fasteners & Related Hardware	1 set	All Fasteners and associated hardware required for installation – packaged separately



# 2 Installation

## 2.1 Before Installation

### 2.1.1 Installation Planning & Service Wiring

**WARNING: RISK OF ELECTRIC SHOCK**

- Do not touch live electrical parts.
- Incorrect connections may cause electric shock.
- Disconnect the power supply to the charging station and verify no power is present before installing, adjusting, or repairing the charging station. Failure to do so may result in physical injury or damage to the power supply system and the charging station.

The charging station must be installed only by a licensed electrician in accordance with the provisions of the local electrical industry construction and should comply with national electrical codes and standards. Before installing the charging station, make sure you have read these instructions in this manual and fully understand its contents. Appropriate protection is required when connecting to a main panel/switchboard. The tools and parts used as outlined in the section “Tools & parts required for installation”.

Prior to installation, locate an available electrical source that can support the following Input Requirements for the Charging Station Per National Electric Code (NEC) requirements:

- For Maximum Output Setting (30A Default Factory Setting), a DEDICATED CIRCUIT FOR EACH PORT rated for minimum 40A; 208-240 VAC, 50-60 Hz, Single Phase must be used. Circuits greater than 40A may also be used.
- A Double Pole Circuit Breaker of the circuit rating must be used. The Charging Unit has a built in GFCI protection; do not provide any additional GFCI protection upstream of the charging unit.



**CAUTION:** The service wiring in this section are specific to North America only. Before installing the Charging Station, identify the type of utility service connection available onsite. If you have unsure about the type of connection available at the service panel, contact your utility service provider.

Prior to mounting, determine location of an acceptable mounting support. All charging station products must be anchored into a mounting support such as a 2” x 4” stud or a solid concrete wall, using mounting hardware that is appropriate for the surface on which you are mounting. DO NOT mount this unit directly to a stucco/drywall/wall board. If installing to a wood stud, use the lag screws provided and ensure the mounting plate is positioned on the centerline of the stud. If mounting onto a concrete, block, or brick wall, use an appropriate anchor for the type of wall on which you are installing the unit.

### 2.1.2 Grounding Instructions

The charging station must be implemented equipment grounding through a permanent wiring system or an equipment grounding conductor. Use a wire with a dedicated grounding wire and a ring terminal and connected to the equipment ground terminal block for grounding.

## 2.2 Tools & Parts Required for Installation

Table 2-1 Tools & parts required for installation

Tool	Size	Source of Supply	Remark
Metric Hex Key (Allen) Wrenches	4mm & 5mm	Commercially Available	For Mounting Fasteners
Phillips Screwdriver	#2 or similar	Commercially Available	For EVOREEL Cable Stop Adjustment & Plug Holder
Torx Driver	T20	Commercially Available	For Charging Station Cover Screws and Lock Screw
Torque Wrench	~ 30 lbf-in	Commercially Available	For tightening all charging station fasteners/screws
Wire, Copper	8 AWG	Commercially Available	UL1015 (recommended) for Input Wiring Hardwire Connection
Heat Shrink Tube x3	For 8 AWG wire	Commercially Available	For Input Wiring Hardwire Connection
Terminal x3	For 8 AWG wire	Commercially Available	For Input Wiring Hardwire Connection
Conduit & Fitting	1" NPT	Commercially Available	For Input Wiring Hardwire Connection

## 2.3 Input Wiring Connection (Optional for p/n: EVO30-101-002)

1. Choose the appropriate conduit and fitting in accordance with all applicable state, local and national electrical codes and standards. Please note the charging station knock-out size for the input wiring connection is 1" NPT.

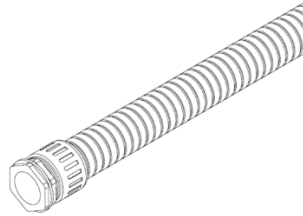

Figure 2-7 Conduit

2. Using the appropriate tool, clamp the wire terminal to the copper wire. For non-insulated terminals, use heat shrink tube to cover the non-insulated portion of the terminal.



Figure 2-8 Copper terminal, heat shrink tube and copper wire.

3. Connecting the electrical wiring to the charging station.
  - 3-1. Place the Charging Station on a flat surface, front cover down with protection under the cover to avoid scratching damage to the cover.
  - 3-2. Remove the Charging Station front cover by loosening the (5) Torx screws at the rear of the charging station. Screw locations are shown in Figure 2-9, below:

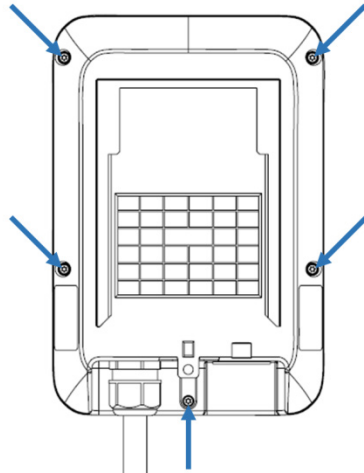

Figure 2-9 Five Torx screw locations to remove the Charging Station Cover



**CAUTION:** For model: \_EVSE EVC4AA0C2B1A1 Non-networked charging station, the LED board is attached to the charging station front cover and the charging station circuit board. Use care to hold the front cover in place and not place force or strain on the wiring harness when the cover screws are removed. Failure to do so may result in damage to the charging station circuit board and/or LED harness, which is not covered under warranty.

- 3-3. With the (5) Torx screws loosened, hold the front cover in place and flip the charging station over on the flat surface so that the front cover is on top. Once this is completed, lift the charging station front cover and place to the right side of the charging station unit. Once this is completed, gently lift the charging station front cover and place to the right side of the charging station unit. Again, use care to not place force or strain on the wiring harness when the front cover screws are removed. Failure to do so may result in damage to the charging station circuit board and/or LED harness.
- 3-4. With the front cover placed to the side, insert the wire end passing through the conduit and insert them into the input wiring hole. (Use Red wire for L1, Black wire for L2, Green-yellow wire for G). Attach the copper wire on the corresponding terminal block. Use the following wire and torque force when connecting to input terminal block, using conductor type other than RHH, RHW and RHW-2 with outer covering.

Model	Terminal	Conductor	Screw	Rating	Torque	
EVOCHARGE EVSE	L1, L2, G	8 AWG	M4	90C, copper wire	16 kgf.cm	13.88 lbf-in

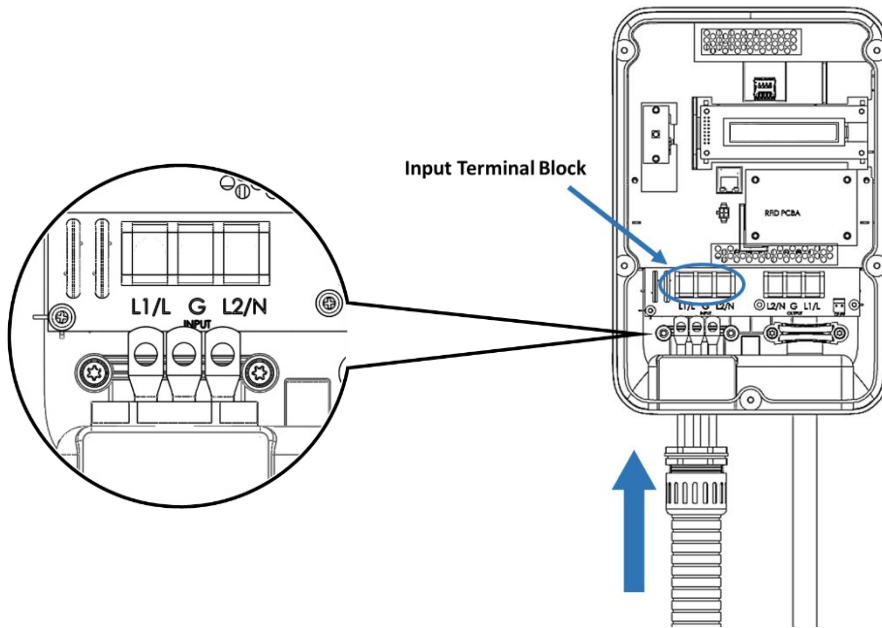

Figure 2-10 Input wiring



**WARNING:** To reduce the risk of fire, connect only to a circuit provided with the appropriate amperes minimum branch circuit overcurrent protection in accordance with the National Electrical Code, ANSI/NFPA 70, and the Canadian Electrical Code, Part I, C22.1.

Model	Current Setting	Circuit Rating Requirement
EVOCHARGE EVSE	30A	40A or greater

4. Once the input wiring and conduit are connected, reassemble the charging station.
  - 4-1. Reinstall the charging station front cover using the following torque force to secure the (5) Torx screws:

Screw	Torque	
M4	16 kgf.cm	13.88 lbf-in

## 2.4 Installation Steps

1. First, secure the charging station mounting bracket to the wall or other suitable structure with appropriate mounting screws. If installing to a wall, ensure the screws are anchored into a suitable wall stud.
2. Follow applicable accessibility requirements for the mounting position. The unit shall be mounted at a sufficient height from ground such that the height of the storage means for the coupling device is located between 24 inches (0.6 m) and 48 inches (1.2 m) from ground per NEC Article 625.
3. The mounting bracket has ten screw holes to support attachment to multiple mounting surfaces. For most installation, including attached the charging station to a single wall stud, only two screws will be used to attach the mounting bracket. In this case, the screws should pass (install) through the middle two vertical screw holes of the mounting bracket as shown in Figures 2-3 & 2-4.

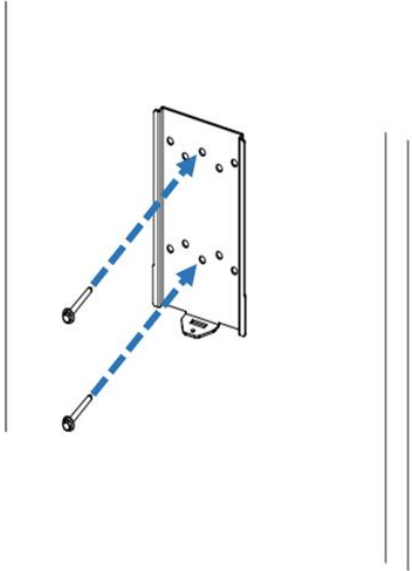

Figure 2-3 Installing the mounting bracket

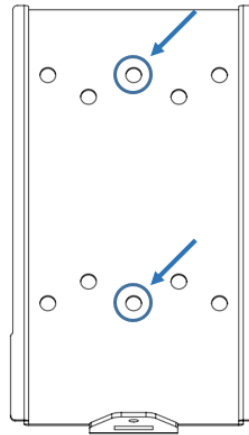

Figure 2-4 Screw holes of mounting bracket

Mounting Screw Recommendations:

- a. For finished walls supported by wood studs, use 1/4" or M6 tapping screws. (Supplied)
- b. For masonry walls, use M6 mechanical screws. (Commercially available)
- c. Use following torque force:

Screw	Torque	
M6	50 kgf.cm	43.4 lb-in
1/4"	50 kgf.cm	43.4 lb-in

- 4. Next, install the EVOREEL to a suitable mounting structure/surface. As previously noted, the charging station (EVOREEL and EVSE box) must be anchored into a mounting support such as a 2" x 4" stud or a solid concrete wall, using mounting hardware that is appropriate for the surface on which you are mounting. DO NOT mount this unit directly to a stucco/drywall/wall board. If installing to a wood stud, use the lag screws provided and ensure the mounting plate is positioned on the centerline of the stud. If mounting onto a concrete, block, or brick wall, use an appropriate anchor for the type of wall on which you are installing the unit.
- 5. Once the EVOREEL unit is installed, install the EVSE box onto its mounting bracket and secure the lock screw as shown in Figure 2-5.

5-1. Tighten the installed M4 screw and screw washer to fix charging station on mounting bracket.

5-2. Use following torque force:

Screw	Torque	
M4	16 kgf.cm	13.88 lbf-in

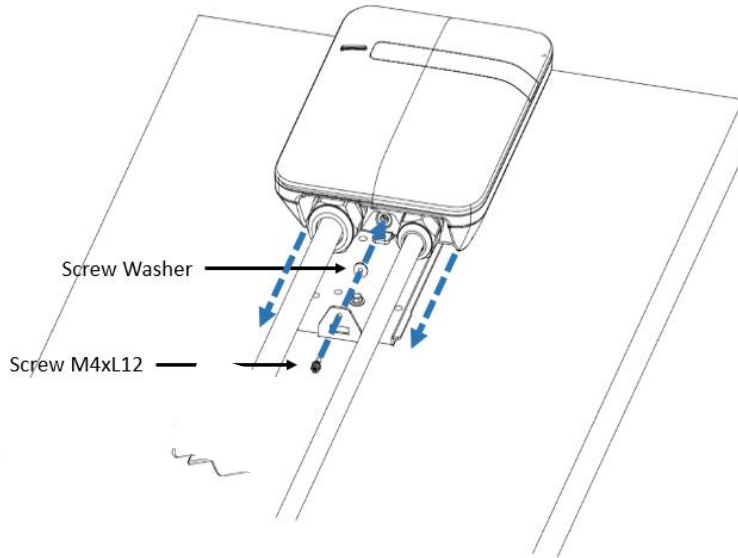

Figure 2-5 Screw locking position

6. Once installed, adjust the EVOREEL cable guide bracket assembly to allow the cable guide and EV Charging Cable/Plug assembly to point/position in the downward direction as shown in Figure 2-6. The roller guide arm can be adjusted by removing the 5/16 hex head bolt and lock washer and rotating the bracket to the downward position. Once repositioned, reinstall the 5/16" hex head bolt and lock washer. (Note: If required for local building codes, an optional Safety Chain Mounting Hole is on the EVOREEL main bracket as shown in Figure 2-6).

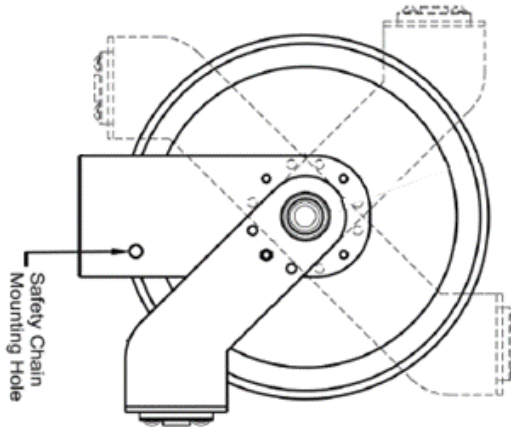

Figure 2-6 EVOREEL Cable Guide Bracket Adjustment

7. After the EVOREEL cable guide brackets are adjusted, adjust the Cable Stop to extend the Charging Plug/Connector to the desired height (Note: For public installations, to meet ADA reach requirements, the Charging Plug/Connector height should not exceed 48 inches from the Ground when the cable is fully retracted). Referring to Figure 2-7, adjust the Cable Stop by loosening the Cable Stop Screws (Step 1), moving the cable stop to the desired position (Step 2) and then fastening the screws to secure the Cable Stop (Step 3).

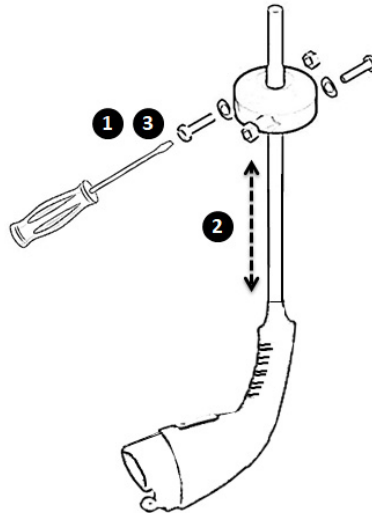

Figure 2-7 Cable Stop Adjustment

## 2.5 Install the Plug and Cable Holder

1. Separate the holder from hook.

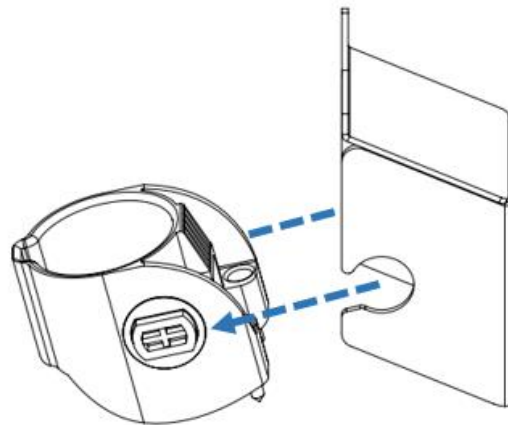

Figure 2-8 Separate the holder

2. The Plug Holder can be installed at any location near. Once the holder installation location is determined, install the holder bracket with the provided screws (x2).

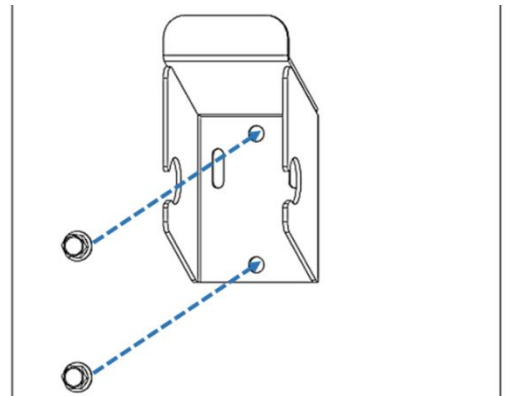

Figure 2-9 Secure the hook

3. Position the plastic holder insert face up and install into the holder bracket.

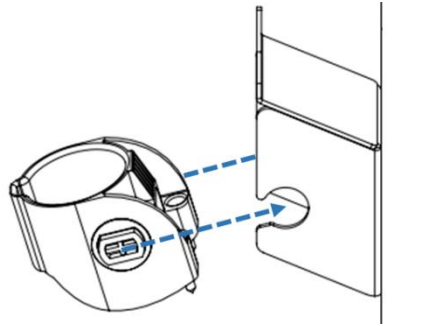

Figure 2-10 Secure the holder

4. Next, rotate the holder insert down.

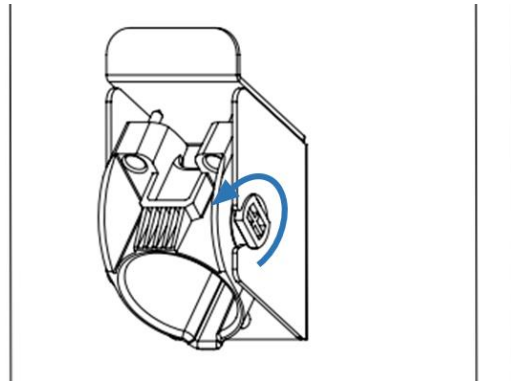

Figure 2-11 Rotate the holder

5. With the holder insert in the down position, tighten the (2) lock/set Phillips screws located at the top of the plastic holder component until snug (do not overtighten). The screws ensure that the plastic holder component remains secured to the holder bracket. The holder can now be used to store the EV plug.

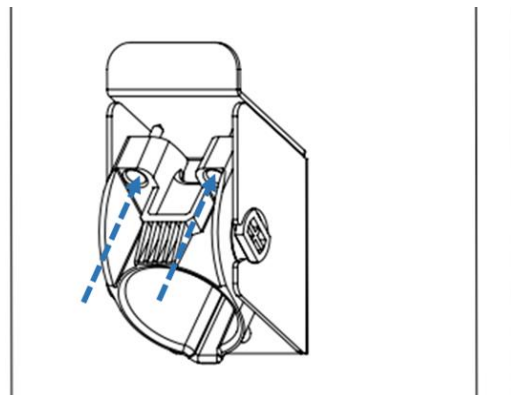

Figure 2-22 Lock screws



## 2.6 Charging Status Indicators

Table 2-2 Charging status indicators

LED Indicator	Description	Definition
	Not illuminated	Power Off
	Green Steady	Ready
	Green Flashing	Flashing green (Fast): Authorized, waiting for EV to initiate charge event. Flashing green (Slow): Suspend (Occupying)
	Blue Flashing	Flashing blue (Slow): Charging
	Red Steady	Unrecoverable Fault
	Red Flashing	Recoverable Fault
	Yellow Steady	Out of Service
	Yellow Flashing	Booting / Firmware Upgrade in process

\*Note: In the instance the “Red Steady” or “Red Flashing” Fault light remains, it is recommended that you:

- Unplug the charging Connector from your EV
- Turn off the power to the Charging Station by switching the upstream circuit breaker to the “OFF” position
- With the circuit breaker in the “OFF” position, wait 1-2 minutes and then switch the upstream circuit breaker back to the “ON” position
- Confirm the Fault light is no longer present. If the Fault light remains, please contact EVOCHARGE.

## 2.7 Charging your Electric Vehicle (EV)

The EVOCHARGE iEVSE Plus supports both “Authorized” (Access Control) operation as well as “Plug and Charge” operation.

When the EVOCHARGE iEVSE Plus is configured to require Authorization, the EVSE must first authorize the operation (via RFID card, mobile app, etc.). The EVSE will only supply energy after authorization.

## 2.7.1 Plug and Charge

This setting must be activated using the web portal – this can be used in instances where access control or payment are not required by the charging station owner.

1. Insert the charging plug into the EV
2. Charging session will automatically commence

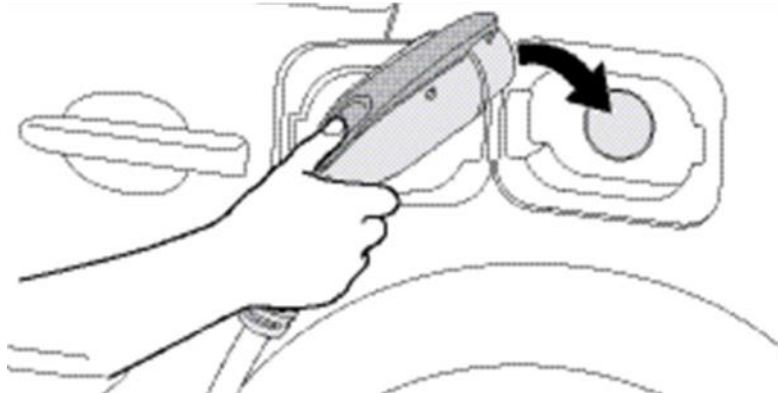
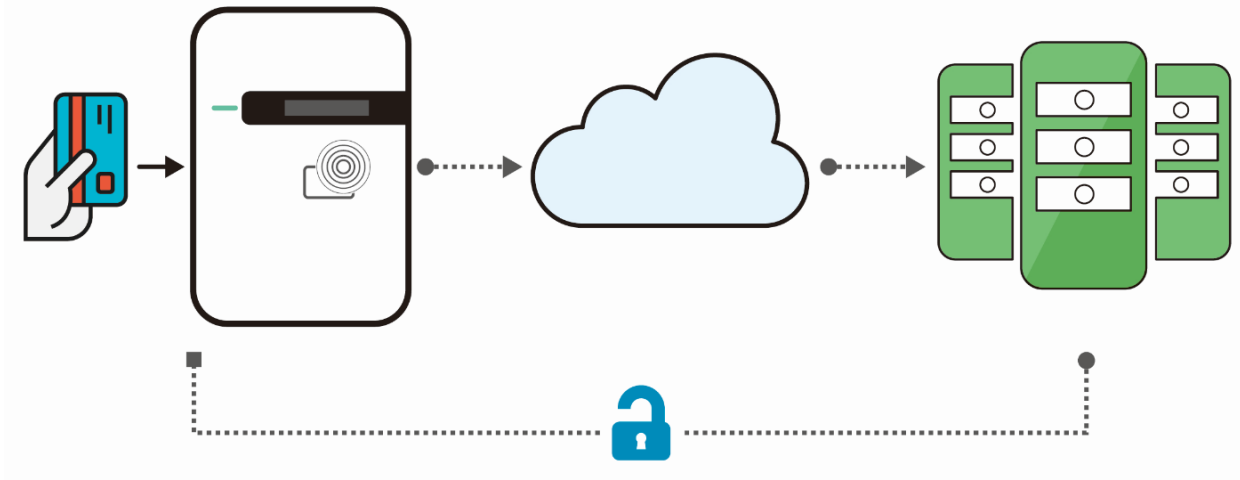

Figure 2-3 Connect the charging plug to the EV

## 2.7.2 Online Authorization

- Authorization via RFID Card and/or mobile app.



## 2.7.3 RFID Card Authorization Local and Offline Authorization

Description:

- Synchronized with the Central System when EVSE is Online.

- To improve the experience for users, the EVOCHARGE iEVSE Plus can be programmed to allow local authorization when EVSE is *offline or not connected to a network*. This also supports faster authorization response time in the instance the communication between EVOCHARGE iEVSE Plus and Central System (Network) is slow to respond.
  1. Insert the charging plug into the EV
  2. Swipe RFID card
  3. Wait for authorization
  4. Charging session will automatically commence once authorized

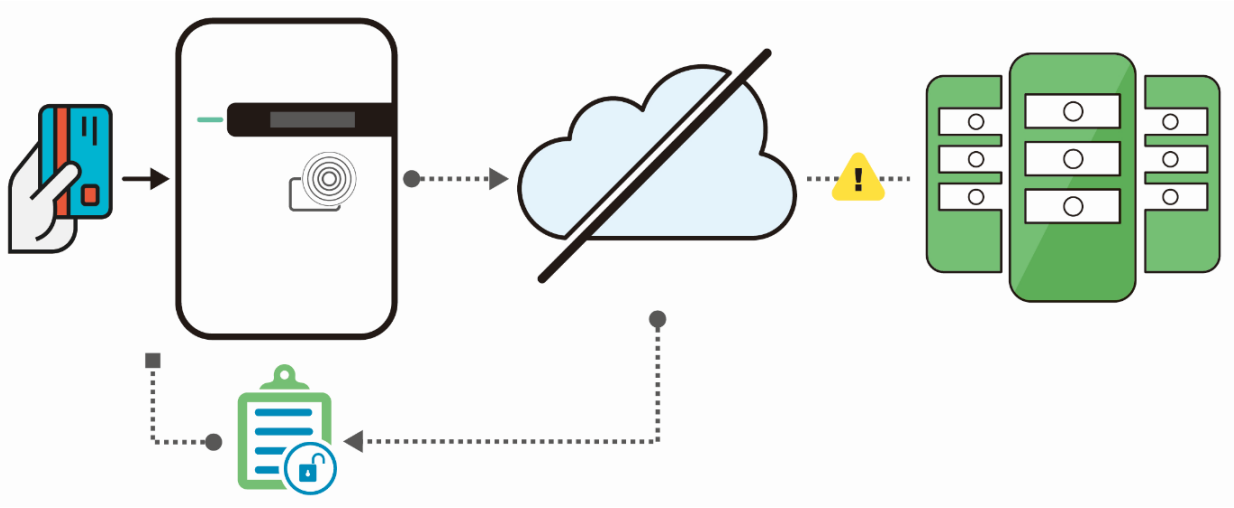

## 2.8 Stop Charging

1. Simply unplug the charging station connector from the EV at any time (once the connector button is depressed, the charging session terminates immediately).
2. Return the connector to the holder.

### 2.8.1 Self-Monitoring and Recovery (Auto Restart)

When a charging session is interrupted due to a temporary error condition, the charging station will automatically restart charging when the cause of the temporary error condition returns to normal. The status indicator lights remain flashing RED until the error condition is resolved.

- Temporary error conditions include: Over Current, Over Voltage, Under Voltage, and Over Temperature.
- For Over Current (OC) conditions: The charging session will be stop while OC occurs. After recovery from OC for 30 seconds, the charging station will automatically restart charging for three times.
- When charging session stopped due to CCID trip, the charging station will try to restart after 15 minutes for 3 times.

## 2.8.2 Power Outage Recovery

When power resumes after an outage, the charging station restarts automatically with a delay ranging from 120 to 720 seconds. The delay is designed to avoid impacting the utility grid when multiple charging stations are in the same area attempting to resume charging simultaneously.

Please refer to STOP CHARGING section for more information.

## 2.9 General Product Care and Use Information

The exterior of the charging station is designed to be waterproof and dust proof (NEMA 4 Outdoor Rated). However, periodic cleaning may be required, depending on local conditions. To ensure proper maintenance of the charging station, follow these guidelines:

- To avoid damaging the finish of the products, only use an automotive grade soft cleaning cloth and if required a mild soap and water mixture to remove accumulation of dirt and dust. Do not use cleaning solvents to clean any of the product components. Despite the water resistance of the enclosure, when cleaning it is preferred to not direct streams of water at the unit – clean with a water damp, automotive grade soft cleaning cloth.
- Make sure the charging connector is put back in the holder after charging to avoid damage.
- Ensure the power cable is stored on the charging station after use to avoid damage.
- If the power cable or the charging connector is damaged, turn off the charging station supply circuit breaker, do not use the charging station, and please contact EVOCHARGE Customer Support for replacement parts.
- When moving or lifting the unit, always grasp and carry by the charging station plastic body. Never attempt to lift, move, or carry the unit by any of the electrical cables. Improper handling may cause damage to the unit.

**EVOCHARGE**<sup>™</sup>

# EVOCHARGE<sup>®</sup> WITH EVOREEL<sup>®</sup> Single and Dual Port Pedestal Mount Charging Stations

---

Installation Guide & User Manual

Revision 1.3



# IMPORTANT SAFETY INSTRUCTIONS

This document contains instructions and warnings that must be followed when installing and using the Electric Vehicle Supply Equipment (EVSE). Before installing or using the EVSE, read this entire document as well as WARNING and CAUTION markings in this document.

## Safety Instructions

The symbols used have the following meaning:

---



WARNING: RISK OF PERSONAL INJURY



WARNING: RISK OF ELECTRIC SHOCK



WARNING: RISK OF FIRE



CAUTION: RISK OF DAMAGE TO THE EQUIPMENT

---

- The charging station must be installed, adjusted, and repaired only by a licensed electrician.
- Make sure that the materials used and the installation procedures follow local building codes and safety standards.
- The information provided in this manual in no way exempts the user of responsibility to follow all applicable codes or safety standards.
- This document provides instructions for the charging station and should not be used for any other product. Before installation or use of this product, review this manual carefully and consult with a licensed contractor, licensed electrician, or trained installation expert to make sure of compliance with local building codes and safety standards.
-  CAUTION: To reduce the risk of fire, connect only to a circuit provided with the minimum branch circuit overcurrent protection requirements in accordance with the National Electrical Code, ANSI/NFPA 70, and the Canadian Electrical Code, Part I, C22.1.

## Repair and Maintenance Clause

- All EVOCHARGE products do not require routine maintenance however, periodic inspections should be conducted to ensure that all parts remain in good working order and no damage exists. Do not attempt to open, disassemble, repair, tamper with, or modify any components of the products – the products are not user serviceable. Contact EVOCHARGE for any repairs.
- Only licensed electricians can repair or maintain the charging station. It is forbidden for general users to repair or maintain it. Turn off input power before performing any repairs or maintenance to the charging station.

## FCC Declaration of Conformity

- This charging station complies with part 15 of the FCC Rules. Changes or modifications the charging station not expressly approved by the manufacturer could void FCC compliance.
- Operation is subject to the following two conditions: (1) This charging station may not cause harmful interference, and (2) this device must accept any interference received, including interference that may cause undesired operation.

## OVERALL WARNINGS & CAUTIONS

### WARNING: RISK OF ELECTRIC SHOCK



Basic precautions should always be followed when using electrical products, including the following:

- Read all the instructions before using this product.
- This device should be supervised when used around children.
- Do not put fingers into the EV connector.
- Do not use this product if the flexible power cord or EV cable is frayed, has broken insulation, or any other signs of damage.
- Do not use this product if the enclosure or the EV connector is broken, cracked, open, or shows any other indication of damage.



### WARNING: RISK OF ELECTRIC SHOCK

Improper connection of the equipment grounding conductor can result in a risk of electric shock. Check with a qualified electrician or serviceman if you are in doubt as to whether the product is properly grounded.



### WARNING: RISK OF ELECTRIC SHOCK

- Do not touch live electrical parts.
- Incorrect connections may cause electric shock.

WARNING: This equipment is intended only for charging vehicles that do not require ventilation during charging. Please refer to your vehicle's owner's manual to determine ventilation requirements.

# Product Features

## EVOCHARGE® With EVOREEL® Dual Port Pedestal Mount Electric Vehicle Charging Stations

- J1772 AC Level 2 (208-240 VAC), 24A (5.8 kW) Continuous Output Rated (Per Port) with adjustable Maximum Current Output capability to Support Multiple Circuit Ratings
- EVOREEL® with EVOCHARGE EVSE® Options:
  - EVOCHARGE iEVSE® True Open Protocol: OCPP 1.6 capable of operating on any OCPP network
  - EVOCHARGE iEVSE® Plus: Access Control via RFID Card (Including without Network Connection) & Mobile App; Payment Capability; Remote Monitoring/Control; Demand Response & Local Load Management
- EVOREEL® with EVOCHARGE® EVSE:
  - Simple Operation: No user interface required with EVSE, simply Plug-in to your EV to initiate charging
- Modern, Elegant & Compact Design: EVSE form factor smaller than a standard sheet of letter-size paper
- Robust Construction, Certified for Outdoor Use: Robust, durable design; tamper-resistant features including provision to install a padlock to secure charging station to mount; NEMA 4 certified for outdoor and indoor use
- Cable & Connector Management: EVOREEL Cable Management with Connector Holder
- Charging Station: UL & cUL Listed, File Number: E469990



## Security and Tamper Feature

In addition to the lock screw that secures the EVOCHARGE iEVSE Plus charging station to the wall mount bracket (Refer to Section 2.3, Note 3., Installing the Charging Station), if desired, a feature is included as part of the charging station and wall mount bracket to install a small padlock for added security and tamper benefits. This feature is located at the bottom of the charging station near the charging station – wall bracket lock screw.

## Self-Monitoring and Recovery | Power Outage Recovery

When a charging session is interrupted due to a temporary error condition, the charging station will automatically restart charging when the cause of the temporary error condition returns to normal. The status indicator lights remain flashing RED until the error condition is resolved.

- Temporary error conditions include: Over Current, Over Voltage, Under Voltage, and Over Temperature.
- For Over Current (OC) conditions: The charging session will be stop while OC occurs. After recovery from OC for 30 seconds, the charging station will automatically restart charging for three times.
- When charging session stopped due to CCID trip, the charging station will try to restart after 15 minutes for 3 times.

When power resumes after an outage, the charging station restarts automatically with a delay ranging from 120 to 720 seconds. The delay is designed to avoid impacting the utility grid when multiple charging stations are in the same area attempting to resume charging simultaneously.

# Product Specifications

## EVOCHARGE® With EVOREEL® Electric Vehicle Charging Stations

Description	Specifications
EVSE Type	SAE J1772; AC Level 2 EVOCHARGE EVSE: Standard, Non-network EV Charging Station EVOCHARGE iEVSE : OCPP 1.6 via LTE Cellular Modem, Wi-Fi or Ethernet connection EVOCHARGE iEVSE Plus: Intelligent, Open Network, OCPP-enabled charging station
Max Output Rating	24A; 5.8 kW Maximum Output Per Port For use with a 40A (or greater) Per Port, Dedicated Circuit
Alternate Adjustable Output Ratings	16A or 24A for use with 20A or 30A Dedicated Circuit
Charge Cable Lengths	Standard: 22 ft. (6.7m); Optional: 30 ft. (9.2m)
Electrical Circuit / Input Power Requirements	208-240VAC, 50/60 Hz. Circuit Requirement: 40A (or greater) Dedicated Circuit Per Port; Branch Breaker: Double pole; Circuit Conductors: Line 1, Line 2, Earth Ground
Input Power Connection	Hardwire, 1" NPT Knockout at Bottom of EVSE
Charging Station Color	Standard: White
Installation Rating	NEMA 4, Indoor/Outdoor Rated
Operational Ratings	Temperature: -22°F to 122°F (-30°C to 50°C); Humidity: 95% RH non-condensing
Mounting	6 ft. Pedestal (Ground) Mount Installation
Overall Dimensions (HxWxD)	EVSE: 11.0 x 7.5 x 3.2 inches (28.0 x 19.0 x 8.1 cm) EVOREEL: 13.8 x 12.0 x 9.2 inches (35.1 x 30.5 x 23.3 cm) Pedestal: 90.0 x 4.8 x 1.7 inches (229.0 x 12.2 x 4.3 cm)
Display & Indicators	LED Charge Status Indicators (Power/Ready, Charging, Fault) & LED Display
Cable Management	EVOREEL Cable Management with Connector Holder
Standards & Compliance	EVSE: UL & cUL Listed, File Number: E469990; SAE J1772, UL 2594, UL 355, CSA

## SAVE THESE INSTRUCTIONS

# Manual Contents

- 1 Introduction & Unpacking..... 7
  - 1.1 Unpacking ..... 7
- 2 Installation ..... 7
  - 2.1 Before Installation..... 7
    - 2.1.1 Installation Planning & Service Wiring ..... 7
    - 2.1.2 Grounding Instructions ..... 8
  - 2.2 Tools & Parts Required for Installation ..... 8
  - 2.3 Installation Steps..... 10
  - 2.4 Input Wiring Connection..... 13
  - 2.5 Install Charging Station to the Mounting Bracket ..... 15
  - 2.6 Install the Plug and Cable Holder..... 16
  - 2.7 Assembled System Reference Images ..... 18
  - 2.8 Charging Status Indicators ..... 21
  - 2.9 Charging your Electric Vehicle (EV)..... 21
    - 2.9.1 Plug and Charge ..... 22
    - 2.9.2 Online Authorization ..... 22
    - 2.9.3 RFID Card Authorization Local and Offline Authorization..... 22
  - 2.10 Stop Charging ..... 23
    - 2.10.1 Self-Monitoring and Recovery (Auto Restart)..... 23
    - 2.10.2 Power Outage Recovery..... 23
  - 2.11 General Product Care and Use Information ..... 24

# 1 Introduction & Unpacking

This user manual applies to the EVOREEL® Dual Port Pedestal Mount Charging Stations for use with all Electric Vehicles (EVs) and Plug-in Hybrid Electric Vehicles (PHEVs) sold in North America.

## 1.1 Unpacking

Unpackage all items and confirm the contents as noted below.

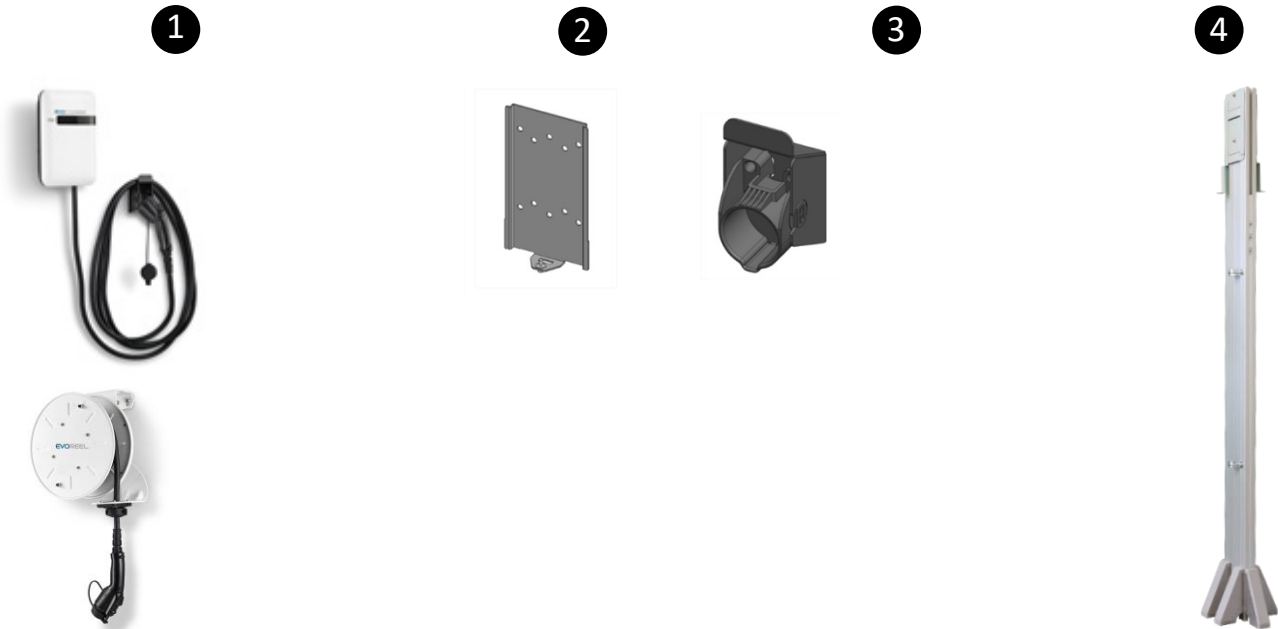

Figure 1-1 Box Contents – Shipped in (3) Separate Boxes

Table 1-1 Box Contents

Item	Description	Qty.	Notes
1	Charging Station with EVOREEL Cable Management System	2	Packaged in (2) Total Boxes
2	Charging Station Mounting Bracket	2	Bracket is Attached to each Charging Station
3	Connector Holder	2	Holder is packaged within cardboard compartment of charging station packaging
4	Pedestal Mount	1	Packaged in (1) Box
5	Mounting Fasteners & Related Hardware	1 or 2 sets	All Fasteners and associated hardware required for installation – packaged separately

## 2 Installation

### 2.1 Before Installation

#### 2.1.1 Installation Planning & Service Wiring



**WARNING: RISK OF ELECTRIC SHOCK**

- Do not touch live electrical parts.
- Incorrect connections may cause electric shock.
- Disconnect the power supply to the charging station and verify no power is present before installing, adjusting, or repairing the charging station. Failure to do so may result in physical injury or damage to the power supply system and the charging station.

The charging station must be installed only by a licensed electrician in accordance with the provisions of the local electrical industry construction and should comply with national electrical codes and standards. Before installing the charging station, make sure you have read these instructions in this manual and fully understand its contents. Appropriate protection is required when connecting to a main panel/switchboard. The tools and parts used as outlined in the section “Tools & parts required for installation”.



**WARNING:** Prior to mounting, determine a location with acceptable ground structural support to mount the Pedestal. All charging station products and pedestal mounts must be anchored into a mounting structure that is approved by local codes and requirements using mounting hardware that is appropriate for the surface on which you are mounting. Please consult with a local building engineer and inspector to determine mounting structure requirements. It is the responsibility of the Installer and/or Charging Station Owner to ensure and confirm that the installation and anchoring of the Product are in full compliance with all Building Code Requirements required of the location of install.

Prior to mounting, locate an available electrical source that can support the following Input Requirements for the Charging Station Per National Electric Code (NEC) requirements:

- For Maximum Output Setting (30A Default Factory Setting), a DEDICATED CIRCUIT FOR EACH PORT rated for minimum 40A; 208-240 VAC, 50-60 Hz, Single Phase must be used. Circuits greater than 40A may also be used.
- NOTE: DUAL PORT UNITS REQUIRE TWO (2) TOTAL DEDICATED CIRCUITS (ONE DEDICATED CIRCUIT FOR EACH PORT).
- A Double Pole Circuit Breaker of the circuit rating must be used. The Charging Unit has a built in GFCI protection; do not provide any additional GFCI protection upstream of the charging unit.



**CAUTION:** The service wiring in this section are specific to North America only. Before installing the Charging Station, identify the type of utility service connection available onsite. If you have unsure about the type of connection available at the service panel, contact your utility service provider.

### 2.1.2 Grounding Instructions

The charging station must be implemented equipment grounding through a permanent wiring system or an equipment grounding conductor. Use a wire with a dedicated grounding wire and a ring terminal and connected to the equipment ground terminal block for grounding.

## 2.2 Tools & Parts Required for Installation

Table 2-1 Tools & parts required for installation

Tool	Size	Source of Supply	Remark
Metric Hex Key (Allen) Wrenches	4mm & 5mm	Commercially Available	For Mounting Fasteners
Metric Wrench	13mm & 17mm	Commercially Available	For Pedestal Mounting (Base) Brackets
SAE Standard Wrenches	9/16" & 5/16"	Commercially Available	For Pedestal Anchors & EVOREEL Cable Guide

<b>Tool</b>	<b>Size</b>	<b>Source of Supply</b>	<b>Remark</b>
			Bracket
Phillips Screwdriver	#2 or similar	Commercially Available	For EVOREEL Cable Stop Adjustment & Plug Holder
Torx Driver	T20	Commercially Available	For Charging Station Cover Screws and Lock Screw
Torque Wrench	~ 30 lbf-in	Commercially Available	For tightening all charging station fasteners/screws
Torque Wrench	Min. 30 lbf-ft	Commercially Available	For tightening the Pedestal Base Anchor Nuts
Wire, Copper	8 AWG	Commercially Available	UL1015 (recommended) for Input Wiring Hardwire Connection
Heat Shrink Tube x3	For 8 AWG wire	Commercially Available	For Input Wiring Hardwire Connection
Terminal x3	For 8 AWG wire	Commercially Available	For Input Wiring Hardwire Connection
Conduit & Fitting	1" NPT	Commercially Available	For Input Wiring Hardwire Connection

## 2.3 Installation Steps

1. Installation Layout Overview: As shown below in Figure 2-1 dependent on dual or single port selection, the final installation layout will:
  - a. Position the EVOREEL cable management systems at the top of the pedestal (Max 8 ft. height to top of EVOREEL).
  - b. Position the charging station (EVSE) units such that the center of the charging station is approximately 48” from the Ground.
  - c. Position the Connector/Plug Holders below the charging station (EVSE) units.



Figure 2-1 Assembly Layout

2. To begin the product assembly, install the (6) Mounting Brackets to the base of the Pedestal Mount as shown in Figure 2-2. Ensure that each of the (6) Mounting Brackets are positioned to be in flush contact with the ground mounting surface.



Figure 2-1 Installing the (6) Mounting Brackets to the Base of the Pedestal

3. With the Pedestal Mounting Brackets installed, position the pedestal in the desired mounting location and use the mounting bracket Anchor Stud/Bolt holes as a template to install the appropriate Anchor Bolts/Studs for mounting the pedestal to the Ground. With the appropriate Anchor Bolts/Studs installed to the mounting surface, install and fasten the Pedestal Mount to the ground.



**WARNING:** Prior to mounting, determine a location with acceptable ground structural support to mount the Pedestal. All charging station products and pedestal mounts must be anchored into a mounting structure that is approved by local codes and requirements using mounting hardware that is appropriate for the surface on which you are mounting. Please consult with a local building engineer and inspector to determine mounting structure requirements. It is the responsibility of the Installer and/or Charging Station Owner to ensure and confirm that the installation and anchoring of the Product are in full compliance with all Building Code Requirements required of the location of install.

The Anchors included with the product are SIMPSON Strong-Tie, Strong-Bolt® 2 Wedge Anchor, Model No. STB2-37334R50, or similar, intended for mounting into appropriate concrete base/pad. Installations instructions for the anchors can be found on the anchor manufacturers website and are also outlined below.

Anchor Installation Instructions:

- 1) Drill a hole in the base material using a carbide drill bit the same diameter as the nominal diameter of the anchor to be installed (3/8"). Drill the hole to the specified minimum hole depth (1-7/8" minimum), and blow the hole clean using compressed air.
- 2) Assemble the anchor with nut and washer so the top of the nut is flush with the top of the anchor. Drive the anchor into the hole to at least the minimum hole depth.
- 3) Tighten the anchor nuts to the required installation torque (30 lbf-ft. for 3/8" bolt diameter).
4. Next, prepare to install all components to the Pedestal Mount using the supplied fastener components. The insertion nuts install into the Pedestal Aluminum Extrusion channel and contain a spring-loaded ball feature to hold them in place during assembly. To install the insertion nuts into the Aluminum Extrusion channel, insert the insertion nuts into the extrusion channel at an angle as shown in Figure 2-3, below:



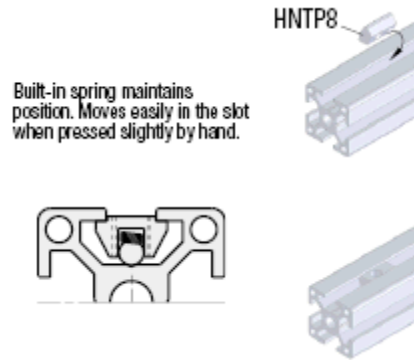

Figure 2-3 Installing the insertion nuts into the aluminum extrusion channel

5. To install each item, install the insertion nuts into the extrusion channel at the approximate positions each item will be installed.
6. Install the EVSE (charging station box) brackets to each side of the pedestal so that the middle of the bracket is approximately 48 inches from the ground. Only two screws will be used to attach the mounting bracket to the pedestal, the screws should pass (install) through the middle two vertical screw holes of the mounting bracket as shown in Figure 2-4.

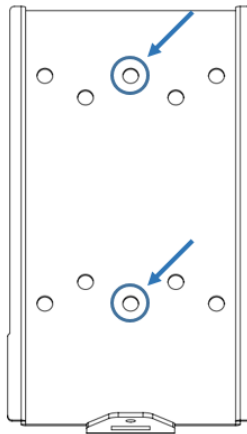

Figure 2-4 Mounting Bracket Screw Hole Locations

7. Next, install the first charging station system (EVOREEL and EVSE box) to one side of the pedestal extrusion.
8. The EVOREEL should first be installed so that it is positioned at the top of the pedestal (Max 8 ft. height to top of EVOREEL). To mount the EVOREEL, use the supplied fasteners along with Thread Locking compound. Please Note: To ensure adequate thread engagement, do not use a flat washer with the EVOREEL mounting screws. Use only the supplied screw and lock washer.
9. Once the first EVOREEL unit is installed, temporarily install the EVSE box onto its bracket to allow the installation process to proceed. Next, complete the installation of the second charging station system (EVOREEL and EVSE box) to the opposite side of the pedestal extrusion.
10. Once both units are installed, adjust the EVOREEL cable guide bracket assembly to allow the cable guide and EV Charging Cable/Plug assembly to point/position in the downward direction as shown in Figure 2-5. The roller guide arm can be adjusted by removing the 5/16 hex head bolt and lock washer and rotating the bracket to the downward position. Once repositioned, reinstall the 5/16" hex head bolt and lock washer. (Note: If required for

local building codes, an optional Safety Chain Mounting Hole is part of the EVOREEL main bracket as shown in Figure 2-5).

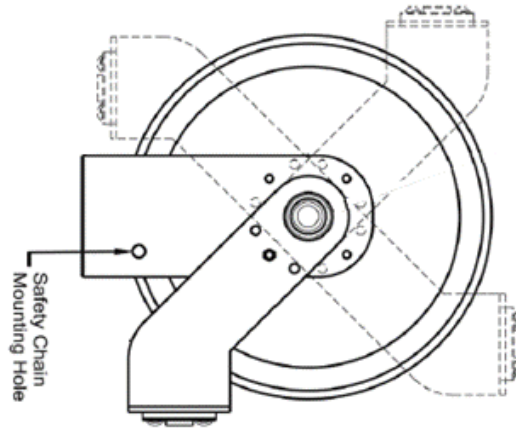

Figure 2-5 EVOREEL Cable Guide Bracket Adjustment

- After the EVOREEL cable guide brackets are adjusted, adjust the Cable Stop to extend the Charging Plug/Connector to the desired height (Note: For public installations, to meet ADA reach requirements, the Charging Plug/Connector height should not exceed 48 inches from the Ground when the cable is fully retracted). Referring to Figure 2-6, adjust the Cable Stop by loosening the Cable Stop Screws (Step 1), moving the cable stop to the desired position (Step 2) and then fastening the screws to secure the Cable Stop (Step 3).

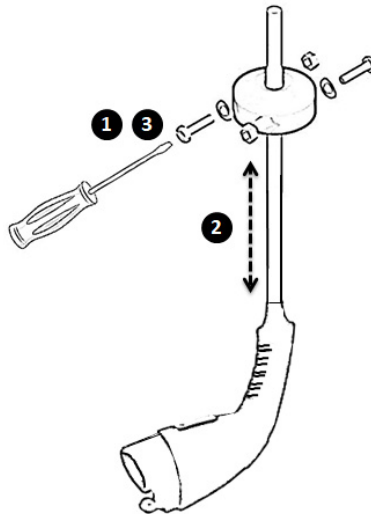

Figure 2-6 Cable Stop Adjustment

## 2.4 Input Wiring Connection

- Choose the appropriate conduit and fitting in accordance with all applicable state, local and national electrical codes and standards. Please note the charging station knock-out size for the input wiring connection is 1" NPT.

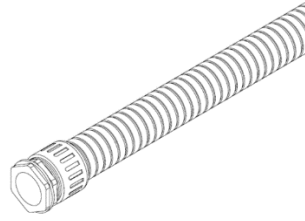

Figure 2-7 Conduit

2. Using the appropriate tool, clamp the wire terminal to the copper wire. For non-insulated terminals, use heat shrink tube to cover the non-insulated portion of the terminal.



Figure 2-8 Copper terminal, heat shrink tube and copper wire

3. Connecting the electrical wiring to the charging station.
  - 3-1. Place the Charging Station on a flat surface, front cover down with protection under the cover to avoid scratching damage to the cover.
  - 3-2. Remove the Charging Station front cover by loosening the (5) Torx screws at the rear of the charging station. Screw locations are shown in Figure 2-9, below:

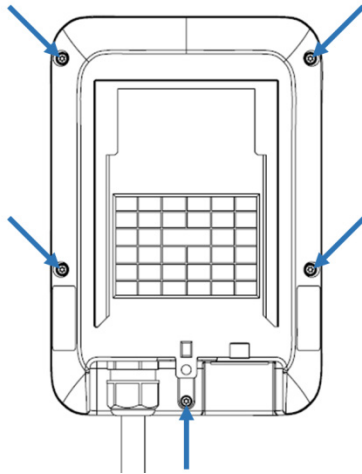

Figure 2-9 Five Torx screw locations to remove the Charging Station Cover



**CAUTION:** For model: EVO30-402-002 (EVSE – Non-networked charging station), the LED board is attached to the charging station front cover and the charging station circuit board. Use care to hold the front cover in place and not place force or strain on the wiring harness when the cover screws are removed. Failure to do so may result in damage to the charging station circuit board and/or LED harness, which is not covered under warranty.

- 3-3. With the (5) Torx screws loosened, hold the front cover in place and flip the charging station over on the flat surface so that the front cover is on top. Once this is completed, lift the charging station front cover and place to the right side of the charging station unit. Once this is completed, gently lift the charging station front cover and place to the right side of the charging station unit. Again, use care to not place force or

strain on the wiring harness when the front cover screws are removed. Failure to do so may result in damage to the charging station circuit board and/or LED harness.

3-4. With the front cover placed to the side, insert the wire end passing through the conduit and insert them into the input wiring hole. (Use Red wire for L1, Black wire for L2, Green-yellow wire for G). Attach the copper wire on the corresponding terminal block. Use the following wire and torque force when connecting to input terminal block, using conductor type other than RHH, RHW and RHW-2 with outer covering.

Model	Terminal	Conductor	Screw	Rating	Torque	
EVOCHARGE iEVSE	L1, L2, G	8 AWG	M4	90C, copper wire	16 kgf.cm	13.88 lbf-in

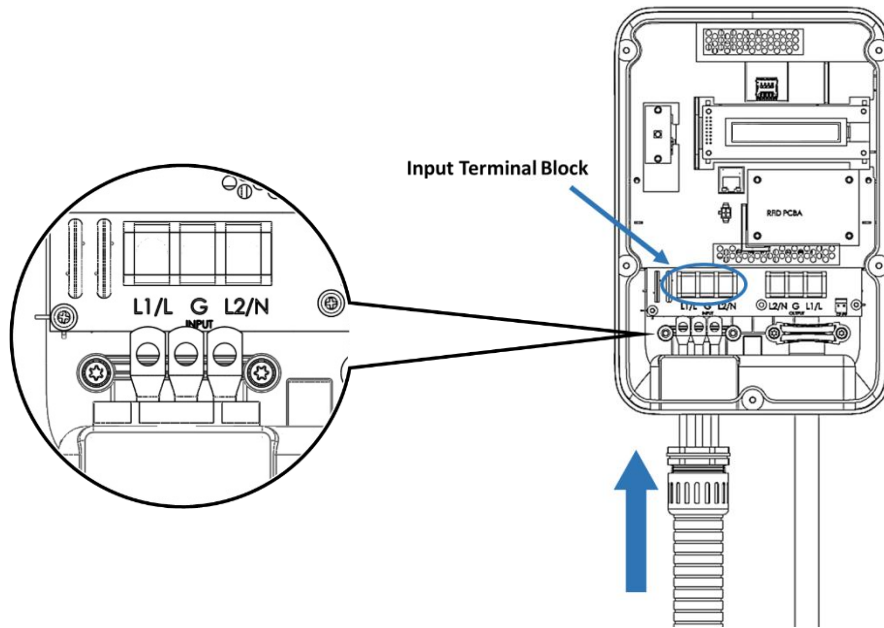

Figure 2-10 Input wiring



**WARNING:** To reduce the risk of fire, connect only to a circuit provided with the appropriate amperes minimum branch circuit overcurrent protection in accordance with the National Electrical Code, ANSI/NFPA 70, and the Canadian Electrical Code, Part I, C22.1.

Model	Current Setting	Circuit Rating Requirement
EVOCHARGE iEVSE	30A	40A or greater

1. Once the input wiring and conduit are connected, reassemble the charging station.
  - 4-1. Reinstall the charging station font cover using the following torque force to secure the (5) Torx screws:

Screw	Torque	
M4	16 kgf.cm	13.88 lbf-in

## 2.5 Install Charging Station to the Mounting Bracket

4. Mount the charging station onto the mounting bracket and secure the lock screw as shown in Figure 2-11.
  - 5-1. Tighten the installed M4 screw and screw washer to fix charging station on mounting bracket.
  - 5-2. Use following torque force:

Screw	Torque	
	M4	16 kgf.cm

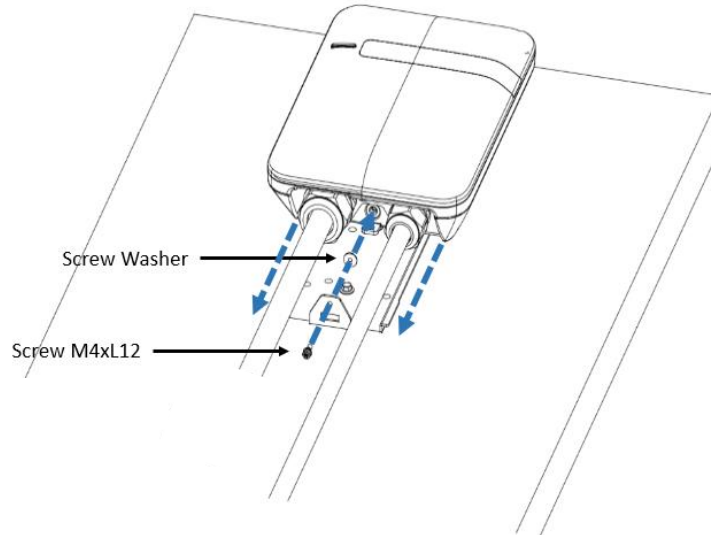

Figure 2-11 Screw locking position

- 5-3. Secure the Conduit to the Pedestal Mount Using the Supplied Conduit Clamps and Mounting hardware.
- 5-4. Next, secure the interconnect cable (the cable between the charging station and EVOREEL) to the side of the pedestal using the supplied “P” clamps and mounting hardware.

## 2.6 Install the Plug and Cable Holder

1. Separate the holder from hook.

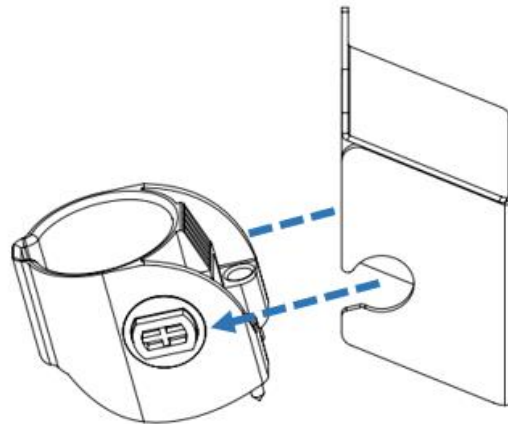

Figure 2-12 Separate the holder

2. The Plug Holder can be installed to the pedestal at any location below the charging station. Once the holder installation location is determined, secure the holder bracket to pedestal with the provided screws (x2).

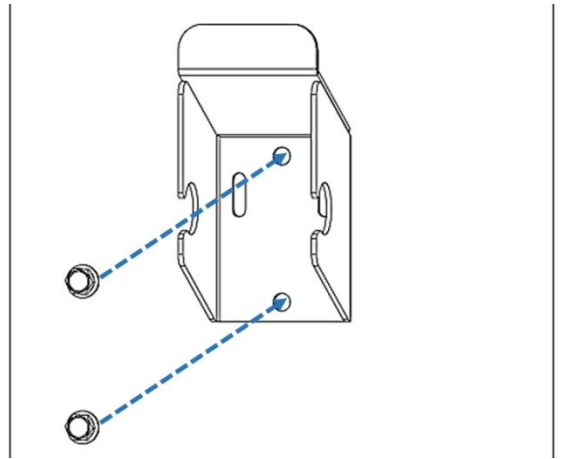

Figure 2-13 Secure the hook

3. Position the plastic holder insert face up and install into the holder bracket.

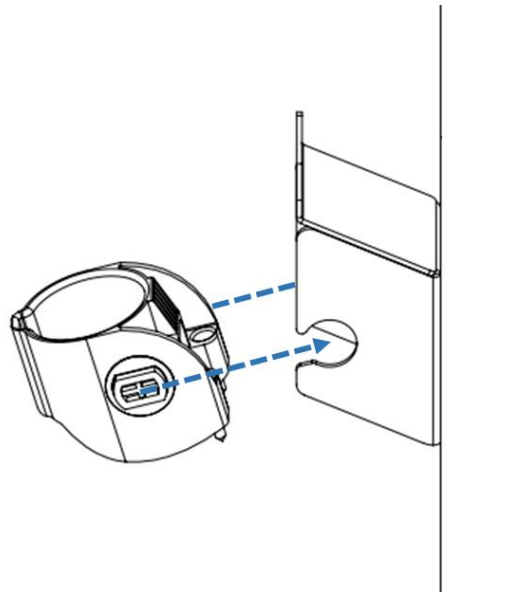

Figure 2-14 Secure the holder

4. Next, rotate the holder insert down.

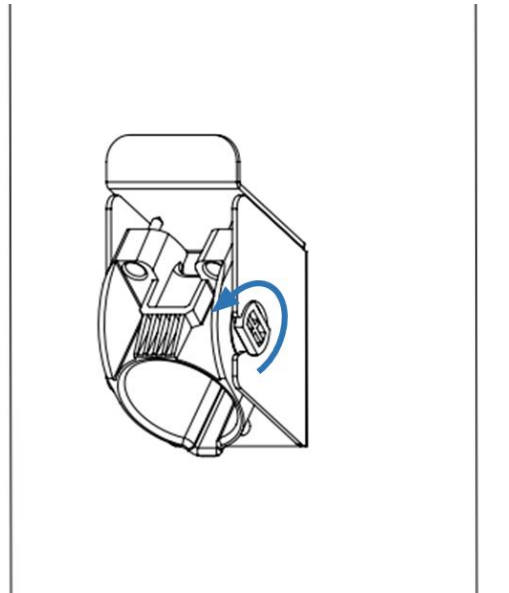

Figure 2-25 Rotate the holder

5. With the holder insert in the down position, tighten the (2) lock/set Phillips screws located at the top of the plastic holder component until snug (do not overtighten). The screws ensure that the plastic holder component remains secured to the holder bracket. The holder can now be used to store the EV plug.

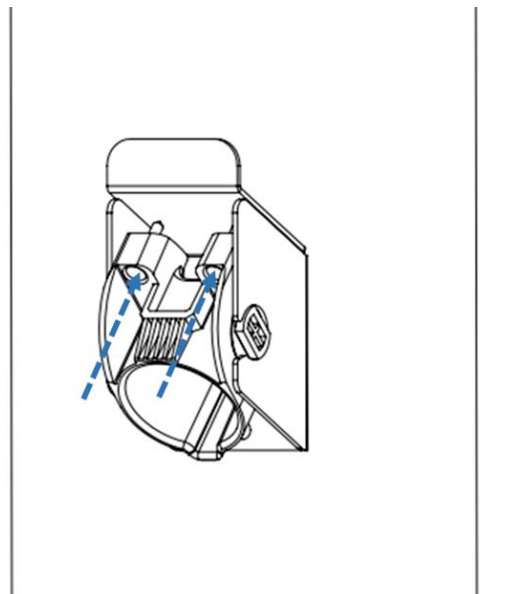

Figure 2-36 Lock screws

## 2.7 Assembled System Reference Images

Below are the complete assembly reference images:



Forward-Facing View

Orient Pedestal Mount so that Charging Stations and EVOREEL Units face perpendicular to parking stall (Charging Stations and EVOREEL Units Mounted on the Side of the Pedestal) as shown in the “Forward-Facing View” image, above.





Forward-Facing View (left image)

Orient Pedestal Mount so that Charging Station and EVOREEL Unit face perpendicular to parking stall (Charging Station and EVOREEL Unit Mounted on the Side of the Pedestal) as shown in the “Forward-Facing View” image, above.

## 2.8 Charging Status Indicators

Table 2-2 Charging status indicators

LED Indicator	Description	Definition
	Not illuminated	Power Off
	Green Steady	Ready
	Green Flashing	Flashing green (Fast): Authorized, waiting for EV to initiate charge event. Flashing green (Slow): Suspend (Occupying)
	Blue Flashing	Flashing blue (Slow): Charging
	Red Steady	Unrecoverable Fault
	Red Flashing	Recoverable Fault
	Yellow Steady	Out of Service
	Yellow Flashing	Booting / Firmware Upgrade in process

\*Note: In the instance the “Red Steady” or “Red Flashing” Fault light remains, it is recommended that you:

- Unplug the charging Connector from your EV
- Turn off the power to the Charging Station by switching the upstream circuit breaker to the “OFF” position
- With the circuit breaker in the “OFF” position, wait 1-2 minutes and then switch the upstream circuit breaker back to the “ON” position
- Confirm the Fault light is no longer present. If the Fault light remains, please contact EVOCHARGE.

## 2.9 Charging your Electric Vehicle (EV)

The EVOIntelligent supports both “Authorized” (Access Control) operation as well as “Plug and Charge” operation.

When the EVOCHARGE iEVSE Plus is configured to require Authorization, the EVSE must first authorize the operation (via RFID card, mobile app, etc.). The EVSE will only supply energy after authorization.

### 2.9.1 Plug and Charge

This setting must be activated using the web portal – this can be used in instances where access control or payment are not required by the charging station owner.

1. Insert the charging plug into the EV
2. Charging session will automatically commence

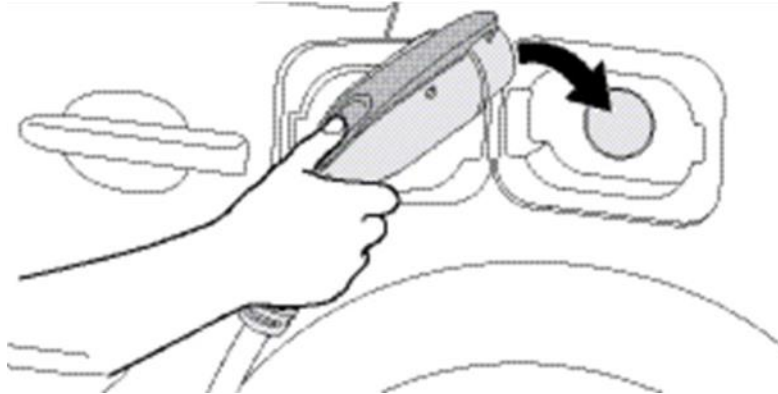
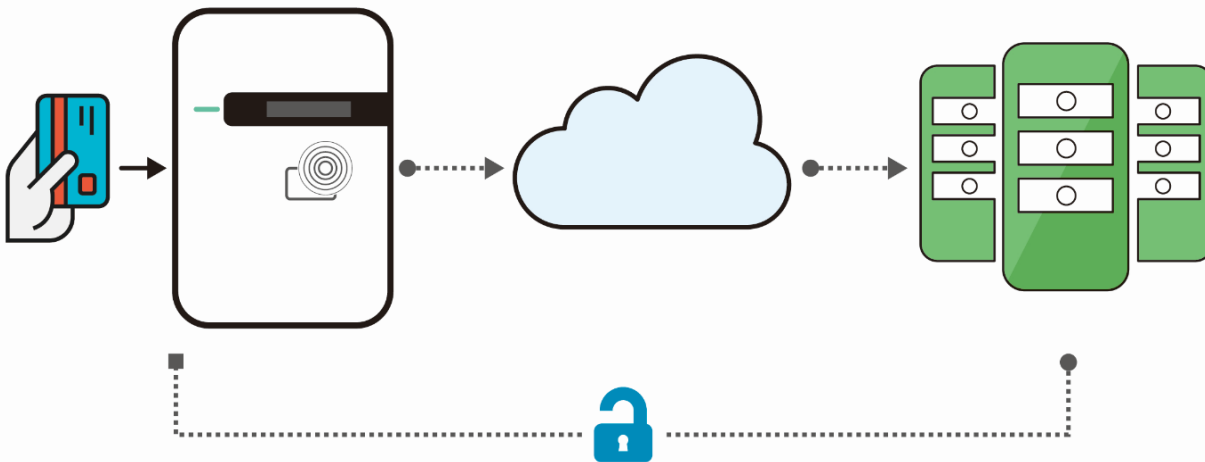

Figure 2-4 Connect the charging plug to the EV

### 2.9.2 Online Authorization

- Authorization via RFID Card and/or mobile app.



### 2.9.3 RFID Card Authorization Local and Offline Authorization

Description:

- Synchronized with the Central System when EVSE is Online.

- To improve the experience for users, the EVOCHARGE iEVSE Plus can be programmed to allow local authorization when EVSE is *offline or not connected to a network*. This also supports faster authorization response time in the instance the communication between EVOCHARGE iEVSE Plus and Central System (Network) is slow to respond.
  1. Insert the charging plug into the EV
  2. Swipe RFID card
  3. Wait for authorization
  4. Charging session will automatically commence once authorized

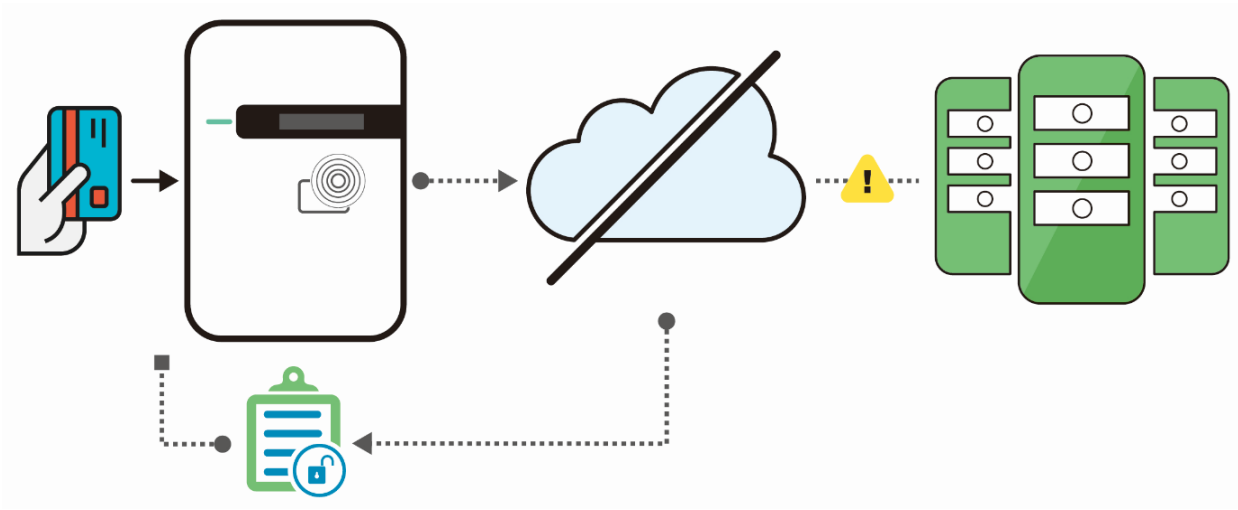

## 2.10 Stop Charging

1. Simply unplug the charging station connector from the EV at any time (once the connector button is depressed, the charging session terminates immediately).
2. Return the connector to the holder.

### 2.10.1 Self-Monitoring and Recovery (Auto Restart)

When a charging session is interrupted due to a temporary error condition, the charging station will automatically restart charging when the cause of the temporary error condition returns to normal. The status indicator lights remain flashing RED until the error condition is resolved.

- Temporary error conditions include: Over Current, Over Voltage, Under Voltage, and Over Temperature.
- For Over Current (OC) conditions: The charging session will be stop while OC occurs. After recovery from OC for 30 seconds, the charging station will automatically restart charging for three times.
- When charging session stopped due to CCID trip, the charging station will try to restart after 15 minutes for 3 times.

### 2.10.2 Power Outage Recovery

When power resumes after an outage, the charging station restarts automatically with a delay ranging from 120 to 720 seconds. The delay is designed to avoid impacting the utility grid when multiple charging stations are in the same area attempting to resume charging simultaneously.

Please refer to STOP CHARGING section for more information.

## 2.11 General Product Care and Use Information

The exterior of the charging station is designed to be waterproof and dust proof (NEMA 4 Outdoor Rated). However, periodic cleaning may be required, depending on local conditions. To ensure proper maintenance of the charging station, follow these guidelines:

- To avoid damaging the finish of the products, only use an automotive grade soft cleaning cloth and if required a mild soap and water mixture to remove accumulation of dirt and dust. Do not use cleaning solvents to clean any of the product components. Despite the water resistance of the enclosure, when cleaning it is preferred to not direct streams of water at the unit – clean with a water damp, automotive grade soft cleaning cloth.
- Make sure the charging connector is put back in the holder after charging to avoid damage.
- Ensure the power cable is stored on the charging station after use to avoid damage.
- If the power cable or the charging connector is damaged, turn off the charging station supply circuit breaker, do not use the charging station, and please contact EVOCHARGE Customer Support for replacement parts.
- When moving or lifting the unit, always grasp and carry by the charging station plastic body. Never attempt to lift, move, or carry the unit by any of the electrical cables. Improper handling may cause damage to the unit.

**EVOCHARGE**<sup>™</sup>

**EVOCHARGE<sup>®</sup> iEVSE<sup>®</sup> –**

**Single or Dual Port 4 ft. Pedestal Mount**

---

Installation Guide & User Manual

Revision 1.2



# IMPORTANT SAFETY INSTRUCTIONS

This document contains instructions and warnings that must be followed when installing and using the Electric Vehicle Supply Equipment (EVSE). Before installing or using the EVSE, read this entire document as well as WARNING and CAUTION markings in this document.

## Safety Instructions

The symbols used have the following meaning:

---



WARNING: RISK OF PERSONAL INJURY



WARNING: RISK OF ELECTRIC SHOCK



WARNING: RISK OF FIRE



CAUTION: RISK OF DAMAGE TO THE EQUIPMENT

---

- The charging station must be installed, adjusted, and repaired only by a licensed electrician.
- Make sure that the materials used and the installation procedures follow local building codes and safety standards.
- The information provided in this manual in no way exempts the user of responsibility to follow all applicable codes or safety standards.
- This document provides instructions for the charging station and should not be used for any other product. Before installation or use of this product, review this manual carefully and consult with a licensed contractor, licensed electrician, or trained installation expert to make sure of compliance with local building codes and safety standards.
-  CAUTION: To reduce the risk of fire, connect only to a circuit provided with the minimum branch circuit overcurrent protection requirements in accordance with the National Electrical Code, ANSI/NFPA 70, and the Canadian Electrical Code, Part I, C22.1.

## Repair and Maintenance Clause

- All EVOCHARGE products do not require routine maintenance however, periodic inspections should be conducted to ensure that all parts remain in good working order and no damage exists. Do not attempt to open, disassemble, repair, tamper with, or modify any components of the products – the products are not user serviceable. Contact EVOCHARGE for any repairs.
- Only licensed electricians can repair or maintain the charging station. It is forbidden for general users to repair or maintain it. Turn off input power before performing any repairs or maintenance to the charging station.

## FCC Declaration of Conformity

- This charging station complies with part 15 of the FCC Rules. Changes or modifications the charging station not expressly approved by the manufacturer could void FCC compliance.
- Operation is subject to the following two conditions: (1) This charging station may not cause harmful interference, and (2) this device must accept any interference received, including interference that may cause undesired operation.

## OVERALL WARNINGS & CAUTIONS

### WARNING: RISK OF ELECTRIC SHOCK



Basic precautions should always be followed when using electrical products, including the following:

- Read all the instructions before using this product.
- This device should be supervised when used around children.
- Do not put fingers into the EV connector.
- Do not use this product if the flexible power cord or EV cable is frayed, has broken insulation, or any other signs of damage.
- Do not use this product if the enclosure or the EV connector is broken, cracked, open, or shows any other indication of damage.



### WARNING: RISK OF ELECTRIC SHOCK

Improper connection of the equipment grounding conductor can result in a risk of electric shock. Check with a qualified electrician or serviceman if you are in doubt as to whether the product is properly grounded.



### WARNING: RISK OF ELECTRIC SHOCK

- Do not touch live electrical parts.
- Incorrect connections may cause electric shock.

WARNING: This equipment is intended only for charging vehicles that do not require ventilation during charging. Please refer to your vehicle's owner's manual to determine ventilation requirements.



# Product Features

## EVOCHARGE® iEVSE® Single Port Pedestal Electric Vehicle Charging Station (EVSE)

- J1772 AC Level 2 (208-240 VAC), 32A Continuous Output Rated (7.68 kW) with adjustable Maximum Current Output capability to Support Multiple Circuit Ratings
- True Open Protocol: OCPP 1.6 capable of operating on any OCPP network
- Intelligent: Access Control via RFID Card (Including without Network Connection) & Mobile App; Payment Capability; Remote Monitoring/Control; Demand Response & Local Load Management
- Modern, Elegant & Compact Design: EVSE form factor smaller than a standard sheet of letter-size paper
- Robust Construction, Certified for Outdoor Use: Robust, durable design; tamper-resistant features including provision to install a padlock to secure charging station to mount; NEMA 4 certified for outdoor and indoor use
- Cable & Connector Management: Standard Connector and Cable Holster, Optional EVOREEL & Retractor Cable Management Systems available from EVOCHARGE.
- Simple, Flexible Mounting Options: Wall Mount (including single stud mount), Pedestal (available from EVOCHARGE)
- UL & cUL Listed, File Number: E469990

## Security and Tamper Feature

In addition to the lock screw that secures the EVOCHARGE iEVSE charging station to the wall mount bracket (Refer to Section 2.3, Note 3., Installing the Charging Station), if desired, a feature is included as part of the charging station and wall mount bracket to install a small padlock for added security and tamper benefits. This feature is located at the bottom of the charging station near the charging station – wall bracket lock screw.

## Self-Monitoring and Recovery | Power Outage Recovery

When a charging session is interrupted due to a temporary error condition, the charging station will automatically restart charging when the cause of the temporary error condition returns to normal. The status indicator lights remain flashing RED until the error condition is resolved.

- Temporary error conditions include: Over Current, Over Voltage, Under Voltage, and Over Temperature.
- For Over Current (OC) conditions: The charging session will be stop while OC occurs. After recovery from OC for 30 seconds, the charging station will automatically restart charging for three times.
- When charging session stopped due to CCID trip, the charging station will try to restart after 15 minutes for 3 times.

When power resumes after an outage, the charging station restarts automatically with a delay ranging from 120 to 720 seconds. The delay is designed to avoid impacting the utility grid when multiple charging stations are in the same area attempting to resume charging simultaneously.

# Product Specifications

## EVOCHARGE® iEVSE® Electric Vehicle Charging Station

Description	Specifications
EVSE Type	Intelligent, Open Network, OCPP-enabled charging station Protocol: OCPP 1.6 via LTE Cellular Modem, Wi-Fi or Ethernet connection
Connector / EVSE Level	SAE J1772; AC Level 2
Max Output Rating	32A; 7.68 kW Maximum Output – For use with 40A (or greater) Circuit Rating
Alternate Adjustable Output Ratings	Fully adjustable and configurable current output setting via EVOCHARGE Web Portal to support any circuit rating
Charge Cable Lengths	18 ft. (7.6m)
Electrical Circuit / Input Power Requirements	208-240VAC, 50/60 Hz.; Circuit Requirement: Dedicated; Branch Breaker: Double pole; Circuit Conductors: Line 1, Line 2, Earth Ground
Input Power Connection	Hardwire (Standard) and Optional Plug-in (NEMA 6-50)
Charging Station Color	Standard: White
Installation Rating	NEMA 4, Indoor/Outdoor Rated
Operational Ratings	Temperature: -22°F to 122°F (-30°C to 50°C); Humidity: 95% RH non-condensing
Mounting	Wall or Pedestal Installation (Optional EVOREEL supports Overhead Mounting)
Overall Dimensions	EVSE: 11.0 x 7.5 x 3.2 inches (28.0 x 19.0 x 8.1 cm) Pedestal: 51.1 x 4.8 x 1.7 inches (130.0 x 12.2 x 4.3 cm)
Display & Indicators	LED Charge Status Indicators (Power/Ready, Charging, Fault)
Cable Management	Standard: Connector/Cable Holder Optional: EVOREEL & Retractor Cable Management
Standards & Compliance	Charging Station: UL & cUL Listed, File Number: E469990; SAE J1772, UL 2594, UL 355, CSA EVOREEL: ETL/cETL listed

# SAVE THESE INSTRUCTIONS

## Manual Contents

1	Introduction & Unpacking.....	7
1.1	Unpacking .....	7
2	Installation .....	8
2.1	Before Installation.....	8
2.1.1	Installation Planning & Service Wiring.....	8
2.1.2	Grounding Instructions .....	9
2.2	Tools & Parts Required for Installation.....	9
2.3	Install the Charging Station & Pedestal .....	9
2.4	Input Wiring Connection (Hardwire Connection).....	11
2.5	Install Charging Station to Wall Bracket .....	13
2.6	Install the Plug and Cable Holder.....	13
3	Operation .....	17
3.1	Charging Status Indicators .....	17
3.2	Charging your Electric Vehicle (EV).....	18
3.2.1	Plug and Charge .....	18
3.2.2	Online Authorization .....	18
3.2.3	RFID Card Authorization Local and Offline Authorization.....	19
3.3	Stop Charging .....	19
3.3.1	Self-Monitoring and Recovery (Auto Restart).....	19
3.3.2	Power Outage Recovery.....	20
3.4	General Product Care and Use Information .....	20

# 1 Introduction & Unpacking

This user manual applies to the iEVSE® for Plug-in Hybrid Electric Vehicles (PHEVs) and Electric Vehicles (EVs).

## 1.1 Unpacking

Unpackage all items and confirm the contents as noted below.

\*Please Note: Do Not discard the packaging material before removing the Plug (Connector) & Cable Holder as well as the Mounting Fasteners for both the Charging Station Mounting Bracket and Connector & Cable Holder – these items are packaged within a compartment of the charging station cardboard packaging.

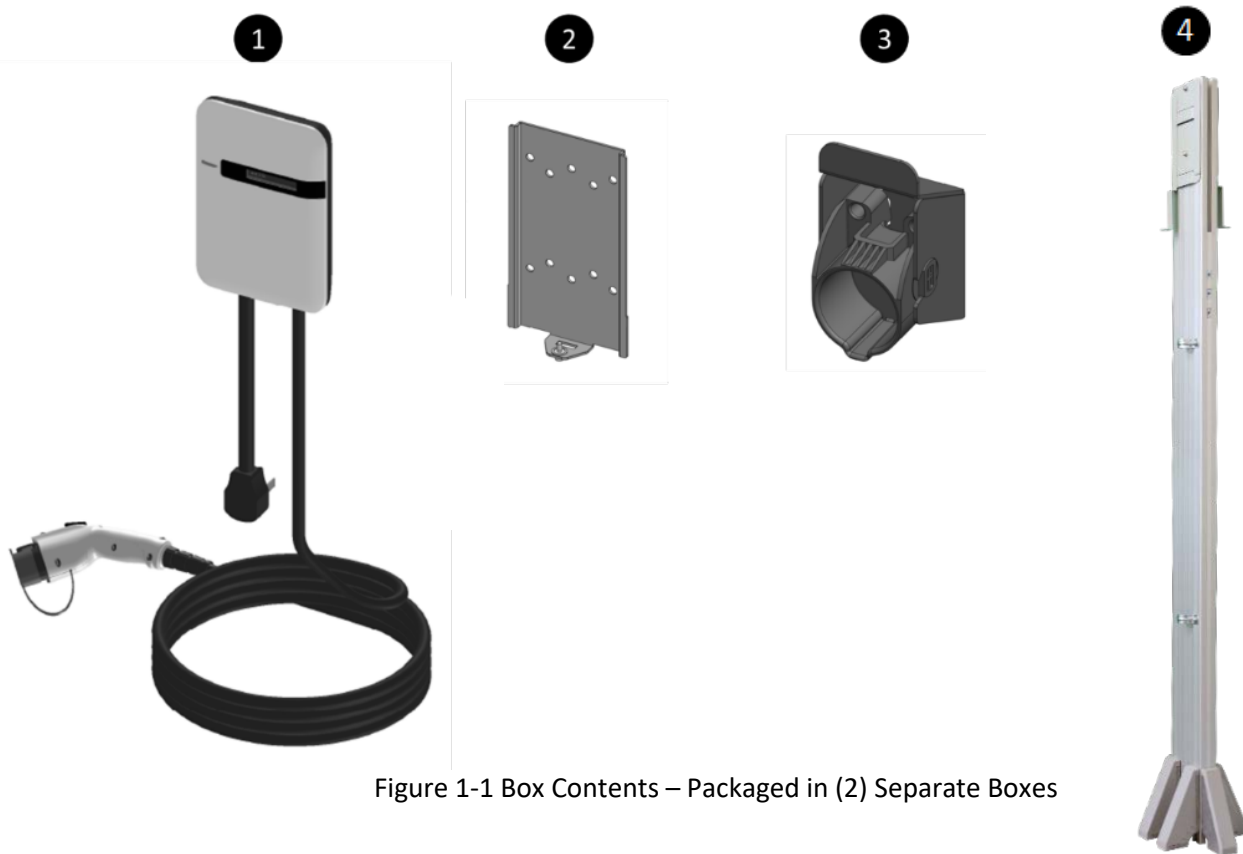

Figure 1-1 Box Contents – Packaged in (2) Separate Boxes

Table 1-1 Box Contents

Item	Description	Qty.	Notes
1	Charging Station	1	
2	Charging Station Mounting Bracket	1	Bracket is Attached to Charging Station
3	Connector & Cable Holder	1	Holder is packaged within cardboard compartment of charging station packaging
4	Pedestal Mount & Mounting Hardware	1	

# 2 Installation

## 2.1 Before Installation

### 2.1.1 Installation Planning & Service Wiring

**WARNING: RISK OF ELECTRIC SHOCK**

- Do not touch live electrical parts.
- Incorrect connections may cause electric shock.
- Disconnect the power supply to the charging station and verify no power is present before installing, adjusting, or repairing the charging station. Failure to do so may result in physical injury or damage to the power supply system and the charging station.

The charging station must be installed only by a licensed electrician in accordance with the provisions of the local electrical industry construction and should comply with national electrical codes and standards.

Before installing the charging station, make sure you have read these instructions in this manual and fully understand its contents.

Appropriate protection is required when connecting to a main panel/switchboard. The tools and parts used as outlined in the section “Tools & parts required for installation”.

Prior to mounting, determine location of an acceptable mounting support. All charging station products must be anchored into a mounting support such as a 2” x 4” stud or a solid concrete wall, using mounting hardware that is appropriate for the surface on which you are mounting. **DO NOT** mount this unit directly to a stucco/drywall/wall board. If installing to a wood stud, use the lag screws provided and ensure the mounting plate is positioned on the centerline of the stud. If mounting onto a concrete, block, or brick wall, use an appropriate anchor for the type of wall on which you are installing the unit.

Prior to mounting, locate an available electrical source that can support the following Input Requirements for the Charging Station Per National Electric Code (NEC) requirements:

- 32A Maximum Output Setting (Default Factory Setting): a DEDICATED CIRCUIT rated for 40A; 208-240 VAC, 50-60 Hz, Single Phase must be used. Circuits rated greater than 40A may also be used.
- Additionally, any Current Output less than 32A can be programmed using the EVOCHARGE Web Portal.
- A Double Pole Circuit Breaker of the circuit rating must be used. The Charging Unit has a built in GFCI protection; do not provide any additional GFCI protection upstream of the charging unit.



**CAUTION:** The service wiring in this section are specific to North America only. Before installing the Charging Station, identify the type of utility service connection available onsite. If you have unsure about the type of connection available at the service panel, contact your utility service provider.

## 2.1.2 Grounding Instructions

The charging station must be implemented equipment grounding through a permanent wiring system or an equipment grounding conductor. Use a wire with a dedicated grounding wire and a ring terminal and connected to the equipment ground terminal block for grounding.

## 2.2 Tools & Parts Required for Installation

Table 2-1 Tools & parts required for installation

Tool	Size	Source of Supply	Remark
Mounting Bracket	194 x 109 x 9 mm	Included with Product	For installing charging station to the wall/structure
Connector & Cable Holder	58 x 58 x 70 mm	Included with Product	To store the EV charging Plug and Cable
Mounting Fasteners x4	1/4" or M6	Included with Product	For installing the Mounting Bracket & Holder to the wall/structure
Socket	5/16" or 8mm	Commercially Available	For Mounting Fasteners
Torx Driver	T20	Commercially Available	For Charging Station Lock Screw and Cover Screws
Philips Screwdriver	PH3	Commercially Available	For Holder Installation and Optional Hardwire Install
Torque Wrench	6 ~ 50 kgf-cm	Commercially Available	For all fasteners
Wire, Copper	8 AWG	Commercially Available	UL1015 (recommended) for Input Wiring Hardwire Connection
Heat Shrink Tube x3	For 8 AWG wire	Commercially Available	For Input Wiring Hardwire Connection
Terminal x3	For 8 AWG wire	Commercially Available	For Input Wiring Hardwire Connection
Conduit	1"	Commercially Available	For Input Wiring Hardwire Connection

## 2.3 Install the Charging Station & Pedestal

- To begin the product assembly, install the supplied (4) Mounting Brackets to the base of the Pedestal Mount. Install the mounting brackets in the center location of each side (4 total) of the pedestal as show in Figure 2-1:



Figure 2-1 Mounting Bracket Screw Hole Locations

Ensure the (4) Mounting Brackets are positioned to be in flush contact with the ground mounting surface.

- With the Pedestal Mounting Brackets installed, position the pedestal in the desired mounting location and use the mounting bracket Anchor Stud/Bolt holes as a template to install the appropriate Anchor Bolts/Studs for

mounting the pedestal to the Ground. With the appropriate Anchor Bolts/Studs installed to the mounting surface, install and fasten the Pedestal Mount to the ground.



**WARNING:** Prior to mounting, determine a location with acceptable ground structural support to mount the Pedestal. All charging station products and pedestal mounts must be anchored into a mounting structure that is approved by local codes and requirements using mounting hardware that is appropriate for the surface on which you are mounting. Please consult with a local building engineer and inspector to determine mounting structure requirements. It is the responsibility of the Installer and/or Charging Station Owner to ensure and confirm that the installation and anchoring of the Product are in full compliance with all Building Code Requirements required of the location of install.

The Anchors included with the product are SIMPSON Strong-Tie, Strong-Bolt® 2 Wedge Anchor, Model No. STB2-37334R50, or similar, intended for mounting into appropriate concrete base/pad. Installations instructions for the anchors can be found on the anchor manufacturers website and are also outlined below.

Anchor Installation Instructions:

- 1) Drill a hole in the base material using a carbide drill bit the same diameter as the nominal diameter of the anchor to be installed (3/8"). Drill the hole to the specified minimum hole depth (1-7/8" minimum), and blow the hole clean using compressed air.
- 2) Assemble the anchor with nut and washer so the top of the nut is flush with the top of the anchor. Drive the anchor into the hole to at least the minimum hole depth.
- 3) Tighten the anchor nuts to the required installation torque (30 lbf-ft. for 3/8" bolt diameter).
3. Next, prepare to install all components to the Pedestal Mount using the supplied fastener components. The insertion nuts install into the Pedestal Aluminum Extrusion channel and contain a spring-loaded ball feature to hold them in place during assembly. To install the insertion nuts into the Aluminum Extrusion channel, insert the insertion nuts into the extrusion channel at an angle as shown in Figure 2-2, below:

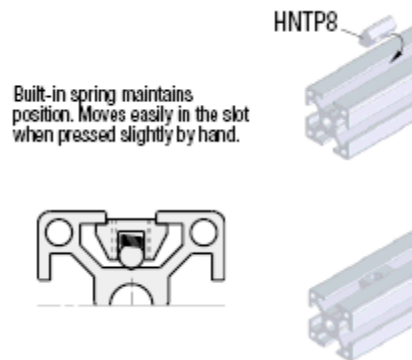

Figure 2-2 Installing the insertion nuts into the aluminum extrusion channel

4. To install each item, install the insertion nuts into the extrusion channel at the approximate positions each item will be installed.
5. Install the EVSE (charging station box) bracket to one side of the pedestal so that the middle of the bracket is approximately 48 inches from the ground. Only two screws will be used to attach the mounting bracket to the pedestal, the screws should pass (install) through the middle two vertical screw holes of the mounting bracket as shown in Figure 2-3.



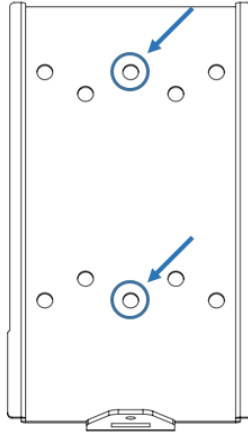

Figure 2-3 Mounting Bracket Screw Hole Locations

6. Next, install the Connector/Plug Holder below the charging station (EVSE) unit.

## 2.4 Input Wiring Connection (Hardwire Connection)

1. Choose the appropriate conduit and fitting in accordance with all applicable state, local and national electrical codes and standards. Please note the charging station knock-out size for the input wiring connection is 1" NPT.

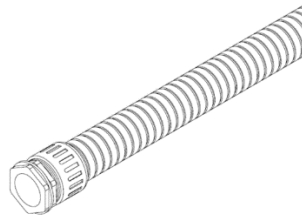

Figure 2-4 Conduit.

2. Using the appropriate tool, clamp the wire terminal to the copper wire. For non-insulated terminals, use heat shrink tube to cover the non-insulated portion of the terminal.



Figure 2-5 Copper terminal, heat shrink tube and copper wire.

3. Connecting the electrical wiring to the charging station.
  - 3-1. Place the Charging Station on a flat surface, front cover down with protection under the cover to avoid scratching damage to the cover.
  - 3-2. Remove the Charging Station front cover by loosening the (5) Torx screws at the rear of the charging station.

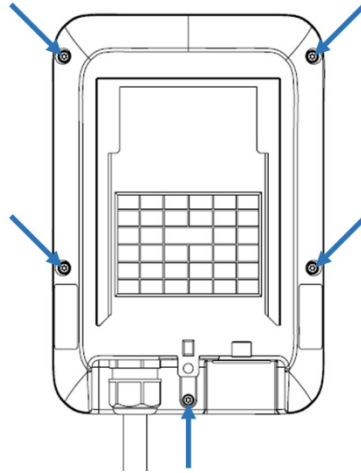

Figure 2-6 Five Torx screw locations to remove the Charging Station Cover

3-3. With the (5) Torx screws loosened, hold the front cover in place and flip the charging station over on the flat surface so that the front cover is on top. Once this is completed, lift the charging station front cover and place to the right side of the charging station unit.

3-4. With the front cover placed to the side, insert the wire end passing through the conduit and insert them into the input wiring hole. (Use Red wire for L1, Black wire for L2, Green-yellow wire for G). Attach the copper wire on the corresponding terminal block. Use the following wire and torque force when connecting to input terminal block, using conductor type other than RHH, RHW and RHW-2 with outer covering.

Model	Terminal	Conductor	Screw	Rating	Torque
EVOCHARGE iEVSE	L1, L2, G	8 AWG	M4	90C, copper wire	16 kgf.cm 13.88 lb-in

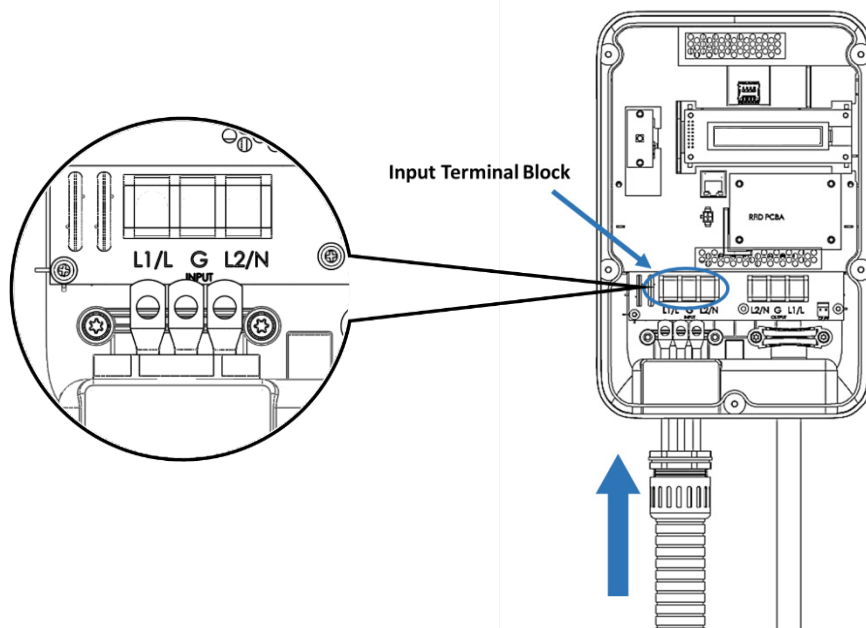

Figure 2-7 Input wiring



**CAUTION:** To reduce the risk of fire, connect only to a circuit provided with the appropriate amperes minimum branch circuit overcurrent protection in accordance with the National Electrical Code, ANSI/NFPA 70, and the Canadian Electrical Code, Part I, C22.1.

Model	Current Setting	Circuit Rating Requirement
EVOCHARGE iEVSE	32A	40A or greater

4. Once the input wiring and conduit are connected, reassemble the charging station.

4-1. Reinstall the charging station front cover using the following torque force to secure the (5) Torx screws:

Screw	Torque	
M4	16 kgf.cm	13.88 lb-in

## 2.5 Install Charging Station to Wall Bracket

7. As shown in Figures 2-8 & 2-9, mount the charging station onto the mounting bracket and secure the lock screw.

4-1. Tighten the installed M4 screw and screw washer to fix charging station on mounting bracket.

4-2. Use following torque force:

Screw	Torque	
M4	16 kgf.cm	13.88 lb-in

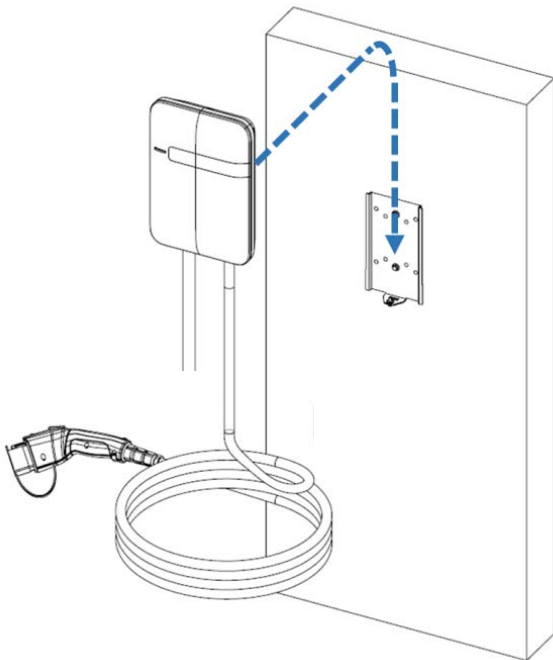

Figure 2-8 Charging station and mounting bracket

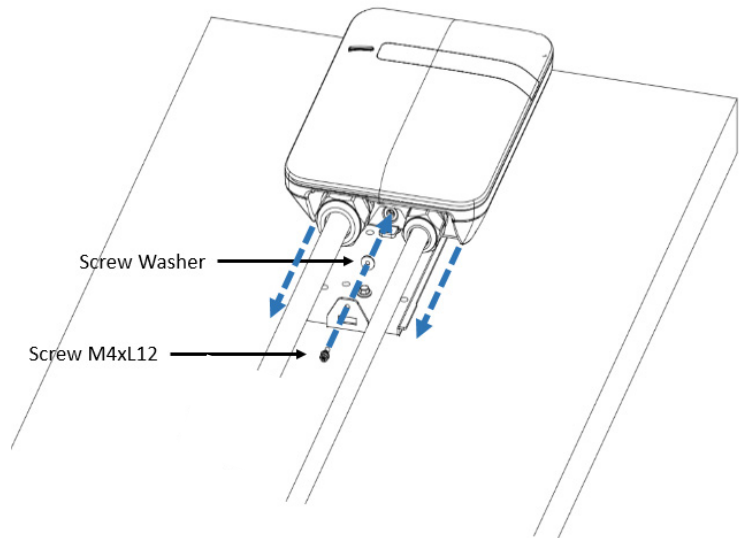

Figure 2-9 Screw locking position

## 2.6 Install the Plug and Cable Holder

1. Separate the holder from hook.

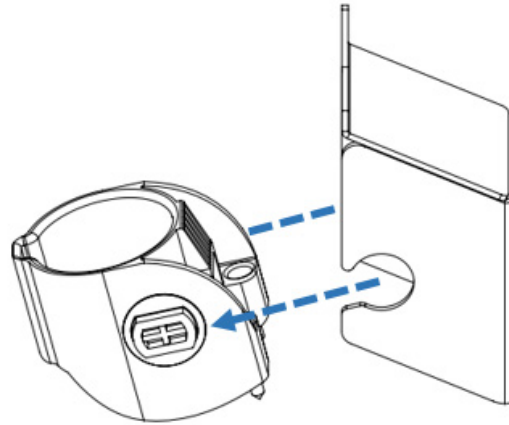

Figure 2-10 Separate the holder

2. Install the Holder bracket (hook) below the charging station using the supplied fasteners

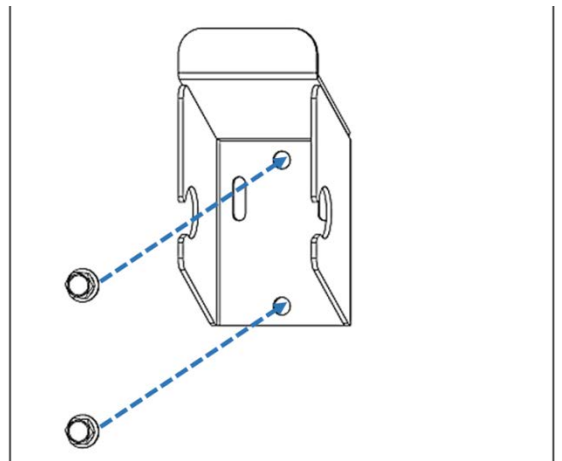

Figure 2-11 Secure the hook

3. Position the plastic holder insert face up and install into the holder bracket.

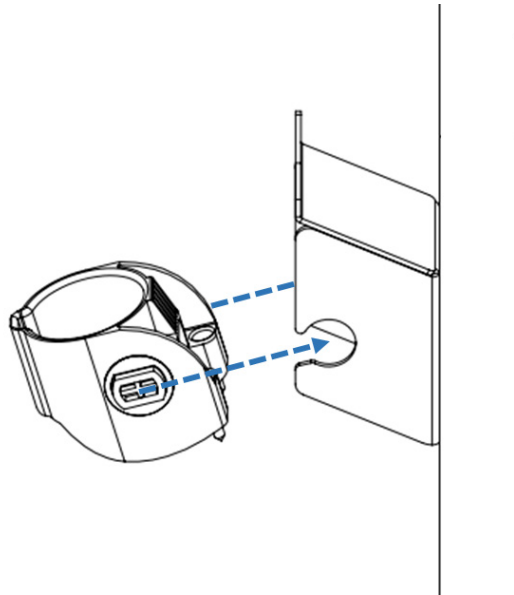

Figure 2-12 Secure the holder

4. Next, rotate the holder insert down.

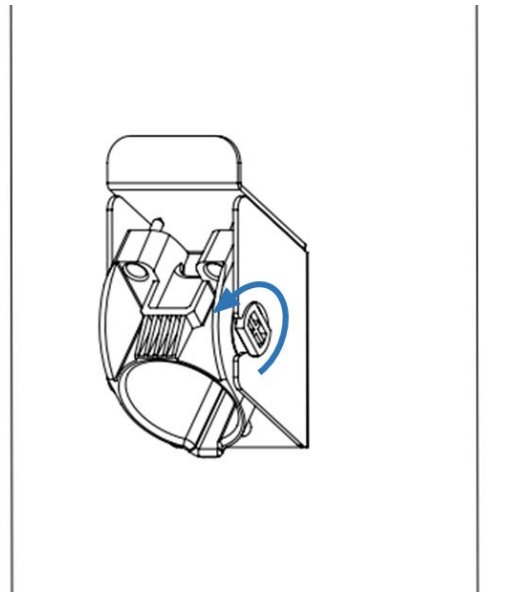

Figure 2-13 Rotate the holder

5. With the holder insert in the down position, tighten the (2) lock/set Philips screws located at the top of the plastic holder component until snug (do not overtighten). The screws ensure that the plastic holder component remains secured to the holder bracket.

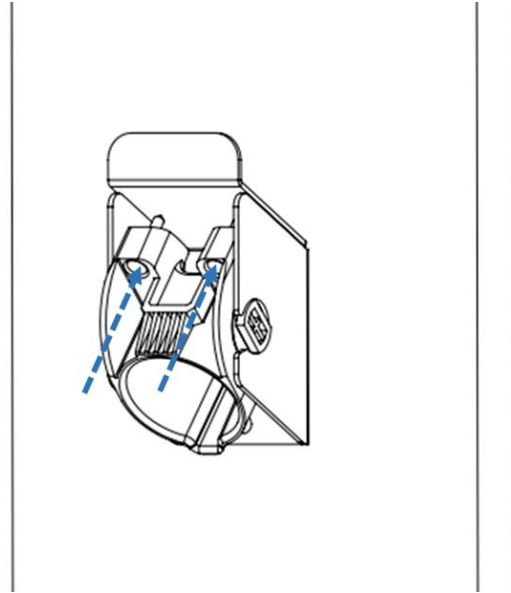

Figure 2-24 Lock screws

6. Insert EV charging connector into the holder.

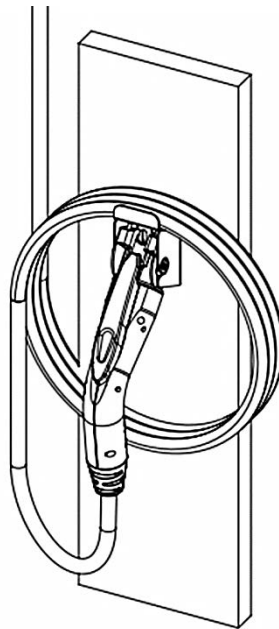

Figure 2-15 Insert EV Charging Connector into Holder

# 3 Operation

## 3.1 Charging Status Indicators

Table 3-1 Charging status indicators

LED Indicator	Description	Definition
	Not illuminated	Power Off
	Green Steady	Ready
	Green Flashing	Flashing green (Fast): Authorized, waiting for EV to initiate charge event. Flashing green (Slow): Suspend (Occupying)
	Blue Flashing	Flashing blue (Slow): Charging
	Red Steady	Unrecoverable Fault
	Red Flashing	Recoverable Fault
	Yellow Steady	Out of Service
	Yellow Flashing	Booting / Firmware Upgrade in process

\*Note: In the instance the “Red Steady” or “Red Flashing” Fault light remains, it is recommended that you:

- Unplug the charging Connector from your EV
- Turn off the power to the Charging Station by switching the upstream circuit breaker to the “OFF” position
- With the circuit breaker in the “OFF” position, wait 1-2 minutes and then switch the upstream circuit breaker back to the “ON” position
- Confirm the Fault light is no longer present. If the Fault light remains, please contact EVOCHARGE.

## 3.2 Charging your Electric Vehicle (EV)

The EVOCHARGE iEVSE Plus supports both “Authorized” (Access Control) operation as well as “Plug and Charge” operation.

When the EVOCHARGE iEVSE Plus is configured to require Authorization, the EVSE must first authorize the operation (via RFID card, mobile app, etc.). The EVSE will only supply energy after authorization.

### 3.2.1 Plug and Charge

This setting must be activated using the web portal – this can be used in instances where access control or payment are not required by the charging station owner.

1. Insert the charging plug into the EV
2. Charging session will automatically commence



Figure 3-1 Connect the charging plug to the EV

### 3.2.2 Online Authorization

- Authorization via RFID Card and/or mobile app.

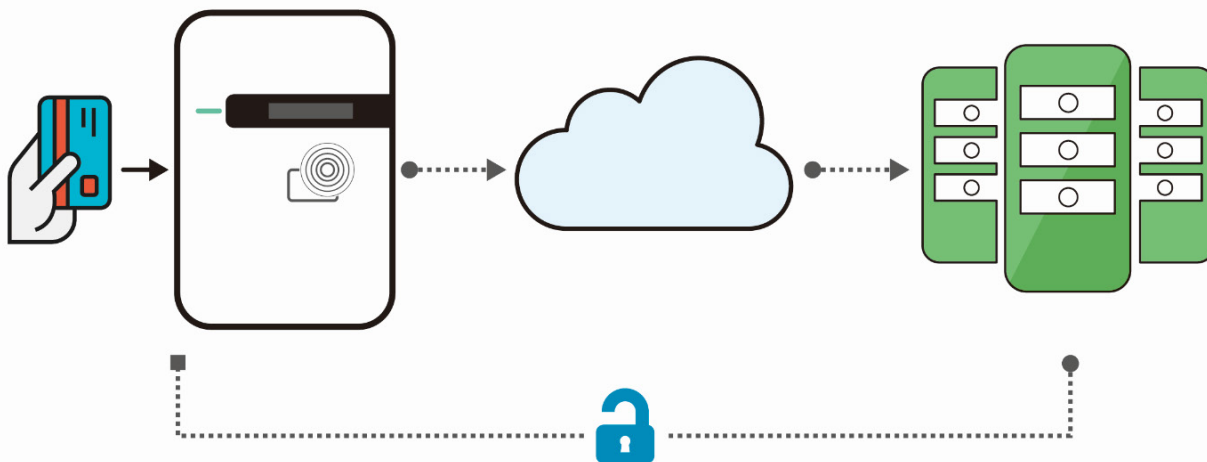



### 3.2.3 RFID Card Authorization Local and Offline Authorization

Description:

- Synchronized with the Central System when EVSE is **Online**.
  - To improve the experience for users, the EVOCHARGE iEVSE Plus can be programmed to allow local authorization when EVSE is *offline or not connected to a network*. This also supports faster authorization response time in the instance the communication between EVOCHARGE iEVSE Plus and Central System (Network) is slow to respond.
1. Insert the charging plug into the EV
  2. Swipe RFID card
  3. Wait for authorization
  4. Charging session will automatically commence once authorized

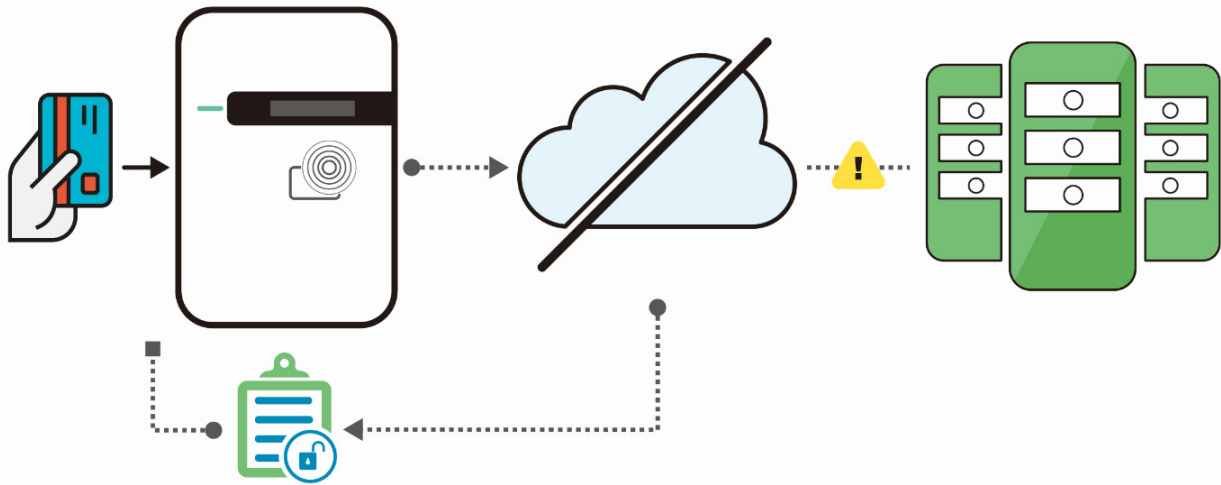

## 3.3 Stop Charging

1. Simply unplug the charging station connector from the EV at any time (once the connector button is depressed, the charging session terminates immediately).
2. Return the connector to the holder.

### 3.3.1 Self-Monitoring and Recovery (Auto Restart)

When a charging session is interrupted due to a temporary error condition, the charging station will automatically restart charging when the cause of the temporary error condition returns to normal. The status indicator lights remain flashing RED until the error condition is resolved.

- Temporary error conditions include: Over Current, Over Voltage, Under Voltage, and Over Temperature.
- For Over Current (OC) conditions: The charging session will be stop while OC occurs. After recovery from OC for 30 seconds, the charging station will automatically restart charging for three times.
- When charging session stopped due to CCID trip, the charging station will try to restart after 15 minutes for 3 times.

### 3.3.2 Power Outage Recovery

When power resumes after an outage, the charging station restarts automatically with a delay ranging from 120 to 720 seconds. The delay is designed to avoid impacting the utility grid when multiple charging stations are in the same area attempting to resume charging simultaneously.

Please refer to STOP CHARGING section for more information.

## 3.4 General Product Care and Use Information

The exterior of the charging station is designed to be waterproof and dust proof (NEMA 4 Outdoor Rated). However, periodic cleaning may be required, depending on local conditions. To ensure proper maintenance of the charging station, follow these guidelines:

- To avoid damaging the finish of the products, only use an automotive grade soft cleaning cloth and if required a mild soap and water mixture to remove accumulation of dirt and dust. Do not use cleaning solvents to clean any of the product components. Despite the water resistance of the enclosure, when cleaning it is preferred to not direct streams of water at the unit – clean with a water damp, automotive grade soft cleaning cloth.
- Make sure the charging connector is put back in the holster after charging to avoid damage.
- Ensure the power cable is stored on the charging station after use to avoid damage.
- If the power cable or the charging connector is damaged, turn off the charging station supply circuit breaker, do not use the charging station, and please contact EVOCHARGE Customer Support for replacement parts.
- When moving or lifting the unit, always grasp and carry by the charging station plastic body. Never attempt to lift, move, or carry the unit by any of the electrical cables. Improper handling may cause damage to the unit.