



**Equipment Supply Company**

# Instruction Manual

## miniLIFT CLASSIC-Mobile Lift

MODEL 92050



## MANUFACTURER'S INTRODUCTION

**ESCO** has carefully produced this instruction manual. It is a condition that before the installation and use of the miniLIFT, the instruction manual, must be read by the operator.

The manual is an essential part of the **miniLIFT CLASSIC [Model 92050]**, which requires proper maintenance during the working life of the lift.

The manual has to be stored and protected from any kind of damaging factors such as high temperature or humidity.

The miniLIFT is also referred to in this manual as the "lift" with both terms meaning the same.

At the end of the manual is the **NOTES SECTION** for keeping record of any services and/or other notations.

Divulgence of this document without the express permission of the manufacturer **ESCO** is strictly prohibited (duplicate or copy). Otherwise **ESCO** will be obliged to take the appropriate legal actions.

The after-sales service at **ESCO** is always at your disposal for any questions.

## INDEX

MANUFACTURER'S INTRODUCTION	2
INDEX	2
GENERAL CHARACTERISTICS	3
DESTINATION OF USE	3
TECHNICAL SPECIFICATIONS	4
PACKAGING AND TRANSPORT	5
INSTALLATION AND CONNECTIONS	6
FREE SAFETY ZONE	6
PERSONAL PROTECTION	6
INSTALLATION AND SET UP	6
IMPLEMENTATION AND VERIFICATION	7
LIFTING OPERATION OF MINILIFT	7
LOWERING OPERATION OF MINILIFT	7
RAISING THE MINILIFT	7
PROPER LIFTING INSTRUCTIONS	8
SECURITIES	9
PROPER INSTALLATION OF SUPPORT STANDS	10
MiniLIFT SAFETY MESURES	11
LIFT INSPECTION AND CARE	11
CLEANING	11
WARRANTY	12
DESTRUCTION	12
NOTES SECTION	12
AVAILABLE OPTIONAL ACCESSORIES	13



## GENERAL CHARACTERISTICS

miniLIFT is a vehicle lift is made with a folding structure and driven by two air bags. This vehicle lift has been developed for body shops to lift the side or the front or rear wheels of vehicles, according to the needs. The lift must only be used to lift a vehicle with the same or inferior weight as the max weight allowed. Capacity of load indicated in this manual and on the unit 5,500 lbs. (*equivilant to 2.500 KG noted on the unit*). If the unit no longer shows the "Capacity Rating" on the labeling please consult an **ESCO** representative for replacement labeling.

## DESTINATION OF USE

This product has been developed for vehicle repair activity and has not been designed to lift people OR any other object. The lift has to be used inside the shop, protected from atmospheric agents (rain, humidity, wind, etc.). Failure to comply with these guidlines may result in failure of the lift and will void warranty.

In this manual you can        the weight of the structure and maximum load. **If any work is carried out on the underside of the vehicle when using the lift additional means of support such as, the use of 2 axle stands is compulsory to ensure the health and safety of the operative.**

Any other action that is not as described in this manual will be at your own risk and considered as tampering and it will render the warranty of this unit void.



**NOTE:** The manufacturer is not responsible in any way for any damage that may result to persons or objects due to improper use of the miniLIFT.



**Technical characteristics and dimensions table**

miniLIFT		
DIMENSION	UNIT	VALUE
Maximum load capacity	Lbs.	5500
Maximum height above the ground	In.	21.65
Minimum height above the ground	In.	5.25
Width of platform	In.	24
Length of platform	In.	54.4
Weight of unit with accessories	Lbs.	55
Required PSI Min-Max		100 -115 PSI
Rise time	sec.	13
Descent time	sec.	17
Measures support arm	In.	see chart



**Chart of machine dimensions**

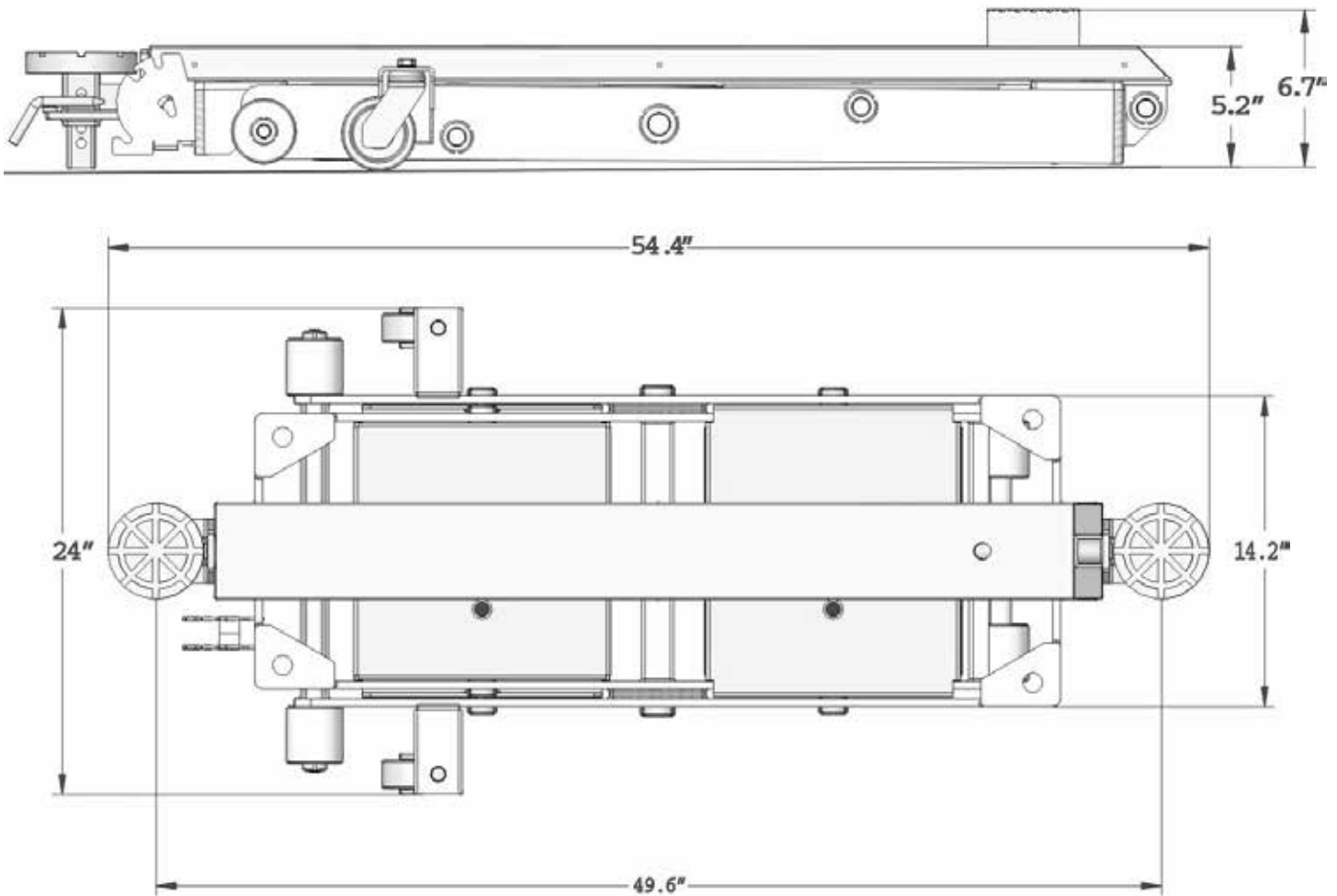

## PACKAGING AND TRANSPORT

All parts of the miniLIFT will be sent on a single pallet:



When opening the packaging, check that all the components are present. The check is to be done in the presence of the carrier, to see if a component is lost. **ESCO** is not responsible for any damage due to transportation, loading, unloading and unpacking.

The movement and transport of packaging must be done according to safety standards and with experienced staff in the transport of mechanical load. Staff should wear appropriate protective clothing. **DO NOT** manually transport the package containing the lift. Inside the packaging all parts are presented separately.

## INSTALLATION AND CONNECTIONS

The miniLIFT is a mobile lift, and has to be used on a smooth and level surface, protected from damaging factors such as temperature and humidity, and protected from the vehicle and lift.

It should not be used on a rough surface or any type that does not meet the minimum requirements for the proper functioning of the lift.

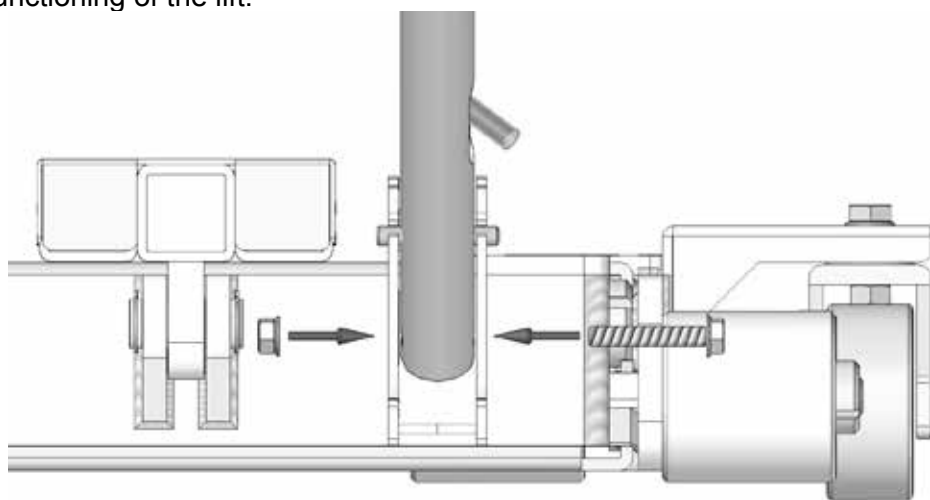

*Diagram shows installation of the operation handle. Make sure to tighten screws completely to ensure handle does not come off the unit.*

**WARNING:** The described operations have to be performed by expert and responsible staff. Before starting the

If using a crane, you are required to comply with the safety standards. Do not touch, or stand within or under the radius of the crane.

If using a crane to carry the lift.

- 
- Pay attention that the straps are properly located at either end of the package.
- Lower the lift to required position on the ground.  
(Necessary security it is recommended to leave a space at a certain distance of another object or wall in the location where you will use the lift.)

**Pneumatic circuit connection**

Initially the lift is not connected to the operating control. The lift connects to the compressed air network using a fast connector, but only when it is in the neutral position, which is the default position. The functioning of the operating control will be explained later in the manual.

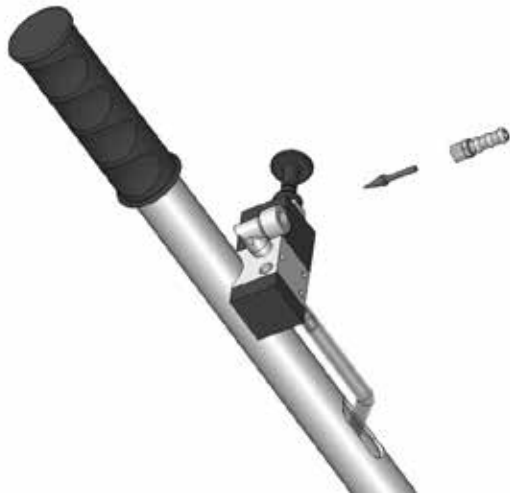

*Install Air Nipple (1/4 INCH NPT) into handle using teflon tape (or equivalent). Properly tighten air nipple onto the handle and test for any leaks in the connection and/or the air hose. DO NOT operate miniLIFT with damaged or leaking air hose and/or input nipple.*

**FREE SAFETY ZONE**

To get the necessary security it is recommended to leave a space at a certain distance of another object or wall in the location where you will use the lift.

Avoiding areas like exits, inclines, parking areas, the lift must be used in a safe area with care by the user. Care should be taken to ensure only the operator is using the work area when operating the miniLIFT. To ensure the safety of the user the lift and its controls should be placed so as to have easy access in case of emergency.

**PERSONAL PROTECTION**

The operator must always wear appropriate work clothes and take all necessary measures to maintain safety, complying with regulations of occupational risk prevention. During use of the lift the user should ensure his own safety, as well as the safety of people and objects around him. The operator must take into account all the recommendations contained in this manual.

**INSTALLATION AND SET UP**

Once the miniLIFT is removed out of the packaging and left on the ground, it is advisable to make a test session to verify the functioning of the commands. The control lever is installed on the handle.

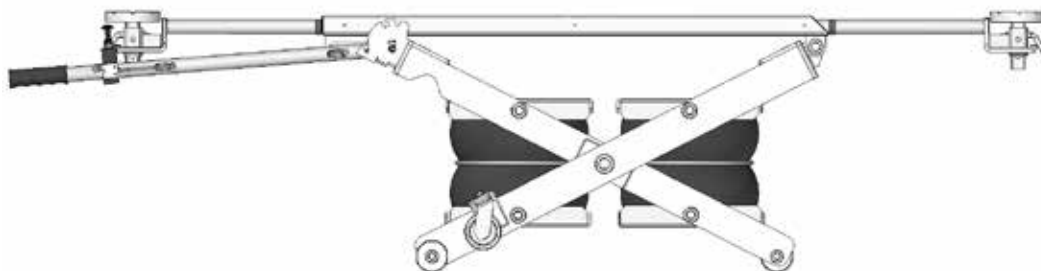

## IMPLEMENTATION AND VERIFICATION

The lift has to be connected to the inlet air line through the quick plug, and the operating control has to be connected to the compressed air network of the workshop. Check that the pressure needed to operate the lift is correct, between 100-115 PSI.

### LIFTING OPERATION OF MINILIFT

After this check it has to be \_\_\_\_\_ if the functioning of the lift is correct. For this the control lever has to be in the position “up” of the operating control. Air will enter into the system, lifting up the lift. When the maximum height is reach, release the lever and the lift will stop.

To raise the lift, the control lever has to be in position “up”.

### LOWERING OPERATION OF MINILIFT



**WARNING:** Before performing any operation ensure that no person or object are below the lift or car. And any support stands have been removed from beneath the vehicle.

To make the lift go down the control lever has to be in position of “down” or \_\_\_\_\_ The lift will descend to the ground.

T

If these operations have been carried out successfully, the **miniLIFT Classic** is ready for use.

### RAISING THE MINILIFT

The commands have to be tested before performing any operation, as described in the previous section 9.1.

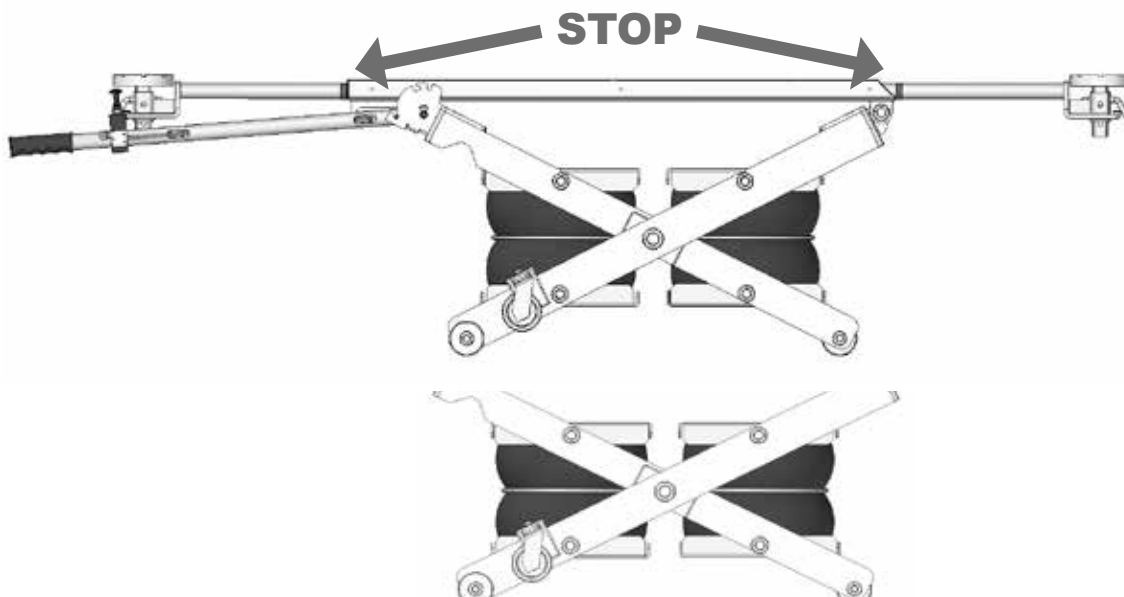

**WARNING:** Before raising the vehicle be sure that the handbrake is not activated and the vehicle is in the neutral gear position.

After having positioned the mobile lift under the vehicle, make sure that the lift is within the width of the vehicle. Once that is done, the arms have to be lengthened until the rubber pad is situated below the point indicated for lift (where the jack is normally situated). The arms must not be extended beyond the “stop” point indicated on the arms. The rubber pads are adjustable in height, and have different positions. There is a pin to set the height of the rubber pads to raise them to the nearest jacking point of the underside of the vehicle.

Once the miniLIFT is placed properly the raising of the vehicle can begin following the guidelines below:

- Verify that in the security-free zone is clear of any person or object as already mentioned in this manual by the manufacturer.
- 
- Continue with the operation only if everything is stable and there is no danger to persons or vehicle.
- Upon reaching the maximum height release the control lever and the lift will stop. The control lever will return automatically to the central position. Disconnection of the air line will not cause the vehicle to descend. Only the operation of the lever in the down position will cause a descent.

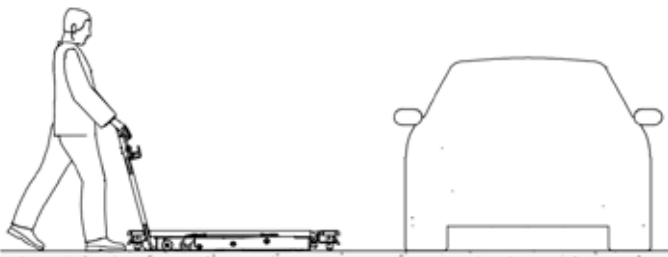

**NOTE:** Wheel the unit under the vehicle completely flattened down and not in the lifting position. This could cause for the lift to damage the vehicle.

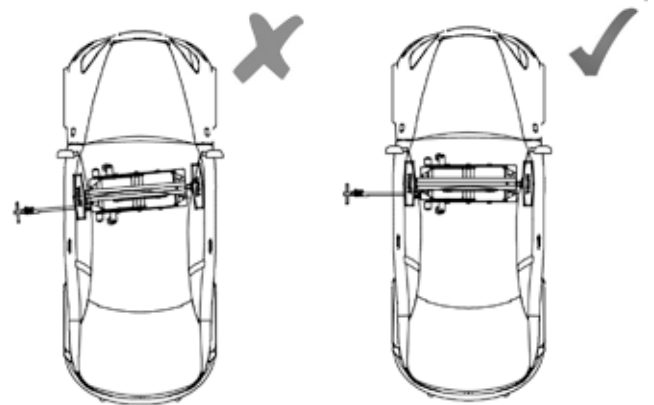

**NOTE:** Make sure the lift is in position underneath the vehicle straight and not at an angle. This will cause for an unstable lifting of the vehicle and could damage the vehicle. ESCO is not liable for any damage made to the vehicle due to the improper use of this lift.

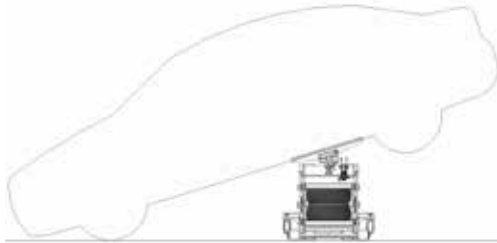

**miniLIFT can lift the vehicle from one end or the other. the minilift is NOT a full vehicle lift system on its own.**

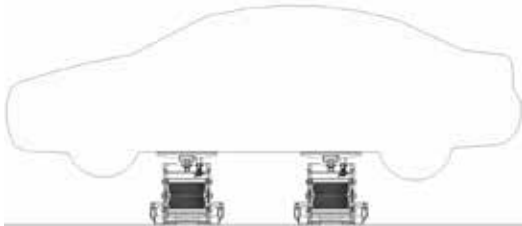

**To lift the entire vehicle, use (2) miniLIFT systems. DO NOT attempt to lift vehicle using only (1) miniLIFT. This could result in damage to the vehicle or even worse serious injury or death.**

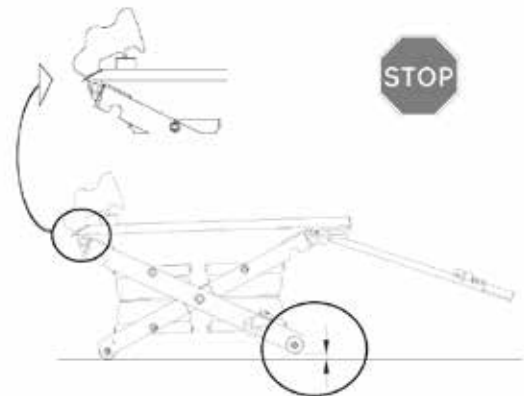

**NOTE:** If at any time the back wheels of the miniLIFT begin to lift off of the ground while the lift is in use STOP IMMEDIATELY. Slowly release the air from the miniLIFT until the wheels are back on the ground safely. REMINDER: miniLIFT must lift on a solid flat foundation.





**WARNING:** **ESCO** will take no responsibility neither civil, criminal or any injury to person that may occur.

## WORKING POSITION

After the lifting operation, before proceeding with the work, the stability of the vehicle on the lift has to be tested. When work will be carried out beneath the vehicle additional means of support such as two axle stands must be used. miniLIFT unit comes complete with (2) Support Stands (lifting capacity of 2,750 lbs per stand). Failure to use support stands to support the load may cause failure of the unit; which will lead to void of warranty, injury and possibly death.

## DOWN LOAD

The control and general operations described in the previous section 9.1 have to be followed, before performing any operation.

T

The control lever will always return to central position; this will ensure that any order has to be entirely driven by the operator. Whenever the operator stops the active command, the lift will stop.



**WARNING:** Before operating the down instruction on the lift check that there are no pipes, nor electric cables crossing the folding structure, because when descending any cable or pipe will be cut. and any support stands have been removed from beneath the vehicle.

## SECURITIES

The miniLIFT can only be used by persons over 18 years, duly trained and authorized, which is the objective of this manual. The lift is not designed to allow work to be carried out beneath the vehicle without the use of additional means of support such as 2 axle stands.

**PROPER INSTALLATION OF SUPPORT STANDS**

All loads **MUST BE SUPPORTED** by an appropriate support system. The miniLIFT is **NOT a support system** It is designed to lift the load, **NOT maintain the weight**. The proper use of support stands **MUST** be applied to the load for proper usage of the miniLIFT system. The miniLIFT system comes with (2) 2,750 lb. capacity per support stand [5,500 lb. total capacity for (2)] that attach to the miniLIFT unit for appropriate and safe support of the load while lifted. ESCO recommends using the provided support stands with the miniLIFT.

ESCO is not liable for the misuse of support stands in conjunction with the miniLIFT system. Any appropriate tonnage support stands may be used to sustain the load.



**NOTE:** The manufacturer is not responsible for the use of unstable or support stands with the miniLIFT and will be considered a void of warranty.

1.

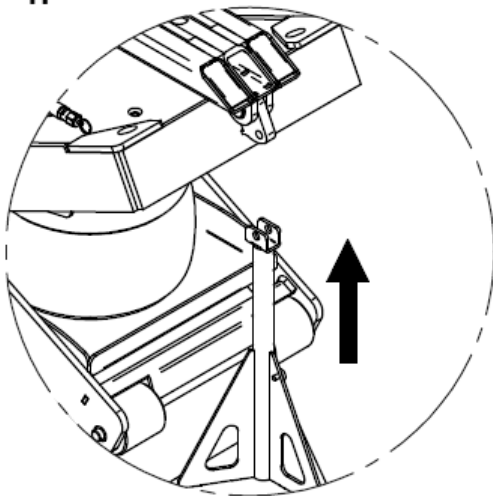

**INSTALLATION:**

*NOTE: Before installing support stands, make sure vehicle height is high enough to maneuver stand under vehicle.*

1. Insert the open end of the support stand into the opening on the end of the miniLIFT as pictured in Figure 1 to the left.

2. Once the support stand is in alignment with the miniLIFT, put the support stand pin through the hole, connecting the support stand to the miniLIFT. Refer to Figure 2 on the right.

*Repeat steps 1. & 2. for the support stand on the other side of the vehicle and miniLIFT.*

2.

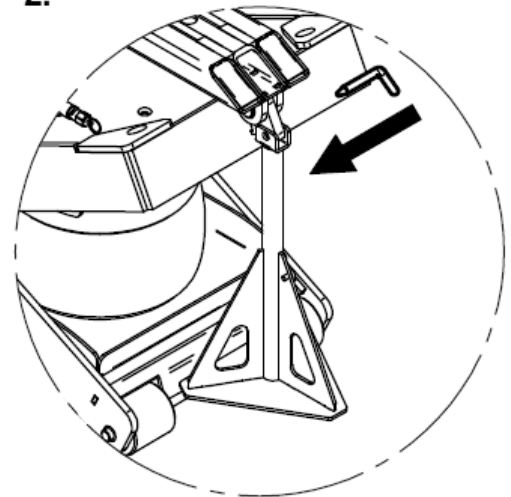

3.

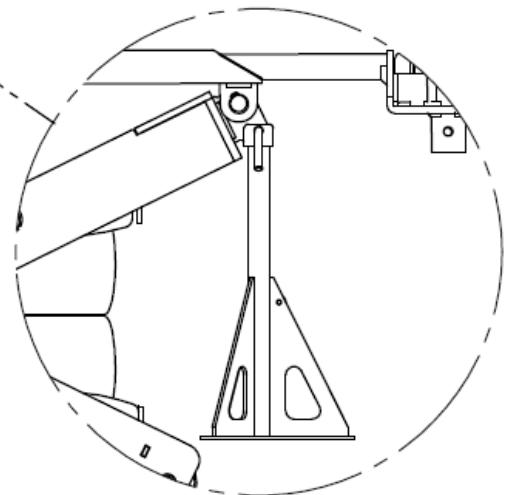
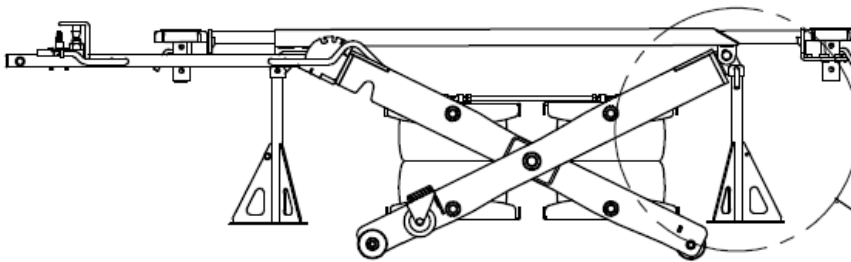

Once the support stands have been properly attached to the miniLIFT system, slowly lower the lift down until the support stands hit the ground. Support stands **MUST** be on a flat even surface. Be sure that both support stands are completely flat on the ground and the load has been supported by the stands (See Figure 3 for example).

Once both support stands are securely positioned and the load is no longer on the miniLIFT, but now on the support stands, the service process may begin.

This instruction manual should be read carefully before use and application of each of the functions of the lift. It is forbidden to use the lift to lift people.

Before the up and down operation, always make sure that the structure is free from any kind of objects or tools.

Always carefully control the load, especially in up load phase, ensuring that the maneuver is being performed correctly. If any problem occurs the lift must be lowered down immediately and vehicle positioned correctly.

CORRECT

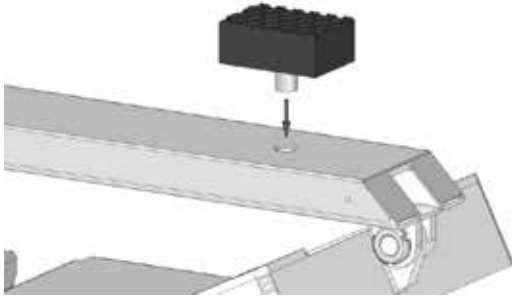

INCORRECT



Clean the surface of the jacking point of the vehicle, so that there is no grease or oil to avoid possible slipping of the vehicle.

Ensure that the pressure of air entering in the circuit is between 100-115 PSI.

The maximum load capacity of the lift is 5,500 lbs.

## MINILIFT SAFETY MEASURES

The only energy source of **miniLIFT Classic** is compressed air taken from the network of the workshop. Therefore, the causes of any anomalies are minimized: There are no electric motors or electrical components in the command, there is also no hydraulic oil cylinder that may lose oil.

When not in use for long periods, disconnect the lift from the air supply, preventing unintentional operations.

## LIFT INSPECTION AND CARE

The lift has to be free of any cargo, to do the inspection. A visual survey of all mechanical parts has to be done and check that there is no break or crack in the pipes or air bags.

The inspection of the pneumatic circuit has to ensure that the connections and tubes are without any damage. There has to be no pressure losses in the circuit. For this we recommend to lift up and down the lift without load and to check that the lift works completely normal.

The folding structure has to be kept clear of debris and dirt. This operation will prevent failures and problems.

## CLEANING

It is recommended to clean the miniLIFT once a week, to remove all dirt and dust that has been accumulated, leaving the work area clean. Never use water

## WARRANTY

The **miniLIFT** carries a warranty on all parts, provided there has not been any tampering or changes to any original part of the lift. For the warranty to be valid it is necessary to register your product through **ESCO** along with maintaining and keeping this manual.



In case of minor repair, replacement parts can be ordered from **ESCO**, but if the repair or replacement is of a major component it must be carried out by a specialist of **ESCO**. This will maintain the integrity of the lift and the warranty.

## DESTRUCTION

In case of destruction of the miniLIFT, it is recommended to apply the regulations of recycling of ferrous elements.

## JOURNAL OF THE MACHINE

This section is available for the user in order to record the observations of working, repairs, or breakdowns, etc. arising over the life of the lift. So you will have a record of information for the machine.

# Available Optional Accessories: miniLIFT

MODEL #92050 & MODEL 92055

Rubber Lifting Pads

MODEL #92057



SUV Conversion Set

MODEL #92057



**miniLIFT.LOW**  
MODEL #92055

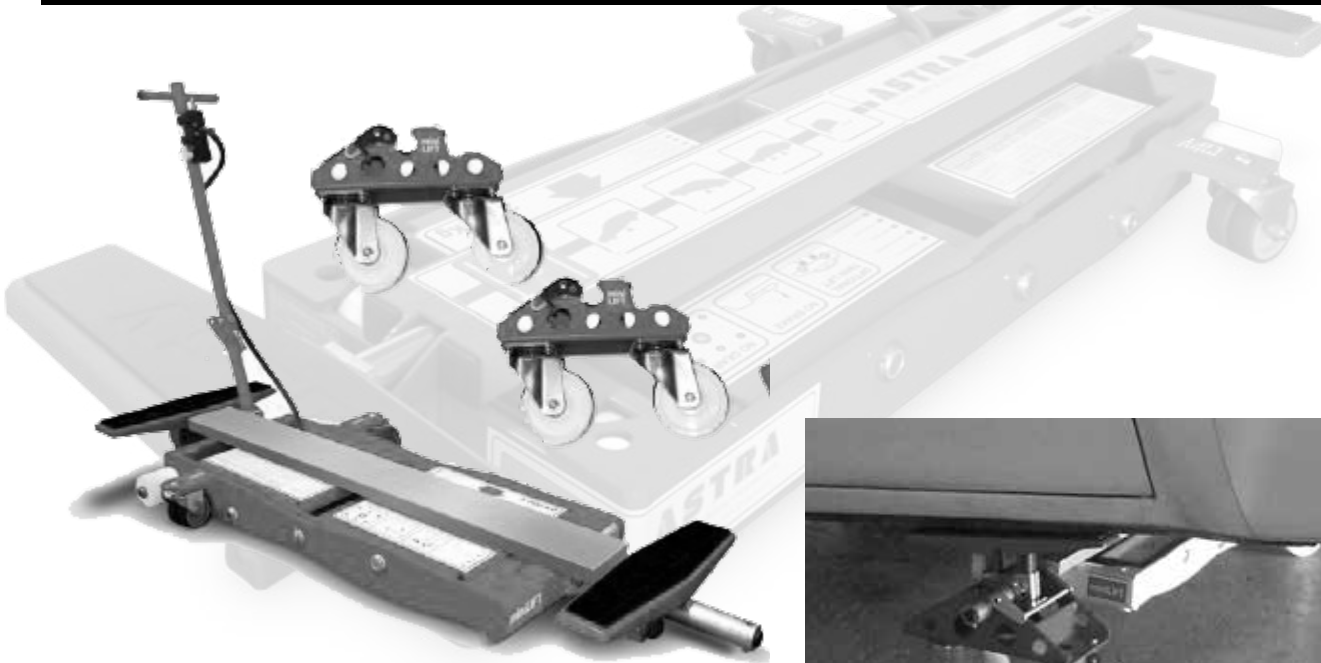

**Compact Mobile Lift with Lift & Move System!**

