



Equipment Supply Company



Instruction Manual

Air Hydraulic Jack - 3 Stage Long Style

ESCO #10771



Please read the warnings and instructions carefully in the manual since they are concerning the important indications and safety of operation and maintenance. The Manufacturer is in no way responsible for eventual damages to persons, animals or equipments caused by improper, erroneous, incorrect and unreasonable application. Before assembly or use of the jack, make sure all parts are included and package contains no damaged parts or components. Please contact ESCO if there are missing or damaged parts/components.

Model 10771, Air Hydraulic Jack - 3 Stage Long Style will be referred to as "air-operated hydraulic pressure jack" throughout instruction manual.

APPLICATION:

Air-operated hydraulic pressure jack is a newly-designed lifting equipment. It utilizes compressed air to promote booster cylinder, to make the hydraulic oil which is stored in oil tank infuse into oil cylinder to move hydraulic cylinder up & down. It adopts the machinery design combination of hydraulic pressure with great advantages of delicate design, small dimension, convenient moving, wide scope of usage, strong jacking capacity and low lifting part. It is a convenient lifting equipment and low labor intensity of automobile manufacturing, repairing, engineering mechanism or heavy-facility.

SPECIFICATIONS:

Model No.	10771
Jacking Capacity	50T/30T/15T/
Air Pressure	90-130 psi
Lowest Height	5.5"
Hoisting Height	50T: 2.2" 30T: 2.04" 15T: 2.2"
Weight	143 lbs.

SAFETY NOTICE:

1. Install the operation rod and host together with fixed axis of operation rod. Place the retaining ring in good order. Insert the air-operated connectors into pipe connectors according to their different outer size. Pull the locked operation rod to carry out 3 different directions: lever direction of operation rod & host, direction of 45 degrees and 90 degrees. (As for operation procedure, please see the label of <Air-operated hydraulic pressure Jack installation instruction> which sticks on the operation rod.)
2. ALWAYS USE clean and dry air pressure (Grease filter must be installed on the air resource), its application scope should be 90-130psi (The MAX. air pressure of safety valve is 130 psi) and within the rated air pressure scope to guarantee life.

3. Connect jack to air supply.
4. Place the air-operated hydraulic pressure jack on a stable, flat, resistant, dry surface without drains or holes when using. If necessary, place a wood board under the air-operated hydraulic pressure jack to avoid any deflection. (Please carefully read the Warnings labels on the handle).
5. When lifting, place support stands or solid supports on the suitable area under raised vehicle to assure security.
6. Before lifting, please estimate the weight of object and vehicles to avoid overload. The life of equipment will be affected strongly if it is overloaded.
7. The air-operated hydraulic pressure jack uses 32w hydraulic oil. Make sure there is enough filtered & clean hydraulic oil to support the jack, or the jack is unable to reach it rated hoisting height. If it lacks of oil, please screw off the bolt of oil tank's filling opening and fill suitable amount of oil then screw on.
8. Don't shake it sharply when using. To move the air-operated hydraulic pressure jack, please keep the wheels balanced with the operation handle in intermediate position.
9. DO NOT place the equipment upside down when using.
10. Please keep the equipment cleaned & out of the reach of children when not using.
11. It is natural & normal for a little bit of oil leaking when transporting, loading and using it in the first time.

TRANSPORT:

The equipment should be packed in carton. Please see the carrying position as below picture:

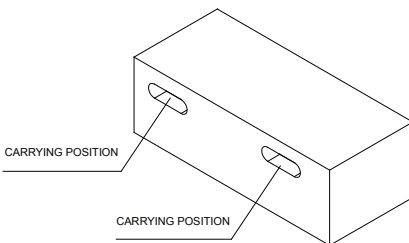

Notice:

1. Carry the equipment with hands in the (carrying position), see picture to the left.
2. Please operate it according to the relative warning indicated on the carton.
3. The operator can move the equipment to any places with the help of operation handle and wheels.

EQUIPMENT INSTALLATION, DISASSEMBLY AND TEST

EQUIPMENT TEST:

- a. When the Equipment is off load within rated air pressure scope, operate the handle of hand valve clockwise to make the Jack move up to the rated hoisting height. After reach the rated hoisting height, boosting system stops working automatically (The MAX. air pressure of safety valve is 130psi). Operate the handle of hand valve anticlockwise to make the jack move down. Dust band and sealing of cylinder work in good order without gas leaking..
- b. Test the equipment with heavy load by special testing machine. It is able to reach the rated jacking capacity and hoisting height within the rated air pressure scope. Dustband and sealing of cylinder work in good order without gas leaking. (The MAX. air pressure of safety valve is 130 psi).

OPERATION AND MAINTENANCE:

I. Operation of air-operated hydraulic pressure jack

- a. Operate the handle of hand valve clockwise to carry out lifting. When the equipment lifts to the rated height; it will stop lifting automatically by itself with the limitation system.
- b. Operate the handle of hand valve counter-clockwise to lower the jack. The equipment will move down automatically by itself with reasonable design principle of air structure.

II. Equipment maintenance and troubleshooting

- c. Add a few drops of lubricating oil regularly on the air inlet every 30 days.
- d. DO NOT keep jack near acid, alkali or corrosive working places.
- e. Check the oil tank to make sure whether there is enough hydraulic oil or not every 30 days.
- f. Keep it clean daily after using.

TROUBLESHOOTING:

Condition	Possible reason	Troubleshooting
Gas-leak under the host	Connector or air pipe doesn't connect in a right way, or air pipe is broken.	Connect again or replace the air pipe or connector after checking.
Gas-leak on oil cylinder	Dust band or sealing and cylinder are broken	Check and replace the dust band or sealing or spare parts.
A little bit of oil leak	Oil runs into air pipe during the course of transporting.	It is unnecessary to repair if it works in good order
A great deal of oil leak	<ol style="list-style-type: none"> 1. The equipment was turned upside down or tilted. 2. Connector of oil inlet or sealing of oil cylinder is broken. 3. Inside wall of cylinder is broken 	<ol style="list-style-type: none"> 1. Starting the equipment under these conditions is strictly prohibited. If it is not in this condition, check and make sure whether there is enough oil in oil tank or not, if not, it should add more. 2. Check and replace spare parts. 3. Check and repair cylinder.
Booster pump does not work	<ol style="list-style-type: none"> 1. One-way valve or spring is broken. 2. Booster piston or booster cylinder is broken 3. Air pressure is not enough, air pipe removed or air inlet is plugged up. 	<ol style="list-style-type: none"> 1. Check and replace the spare part. 2. Check and repair, replace the spare part if necessary. 3. Check the air pressure whether is within 90-130psi and the air way is broken or not.
Booster pump works in good order but cylinder does not move up.	<ol style="list-style-type: none"> 1. Lack of oil. 2. The steel ball of one-way valve is plugged up. 3. Oil Cylinder is broken. 	<ol style="list-style-type: none"> 1. Fill it with hydraulic oil. 2. Take the connector of oil inlet apart and take out the one-way valve and spring to clean it. 3. Check and repair cylinder.
It works with off load but it does not move up or moves up slowly with heavy load.	<ol style="list-style-type: none"> 1. Air pressure is not enough, air pipe removed or air inlet is plug up. 2. one-way valve is plugged up. 3. Hydraulic oil became thick 	<ol style="list-style-type: none"> 1. Check the air pressure whether is within 90-130psi and the air way is broken or not. 2. Check and Take every one-way valve apart and clean them. 3. Replace the hydraulic oil.

WARNING:

1. Air-operated hydraulic pressure jack is a lifting tool when using. It can not be used as a supporting tool. Without any secured stands or solid supports on the suitable area under raised vehicle to assure security, ALL operators are strictly prohibited to work after the equipment moved up. (Please carefully read the Warning label on the operation handle).
2. Use the Air-operated hydraulic pressure jack on a flat and resistant surface away from drains and holes. It is not allowed to use it on a slope floor to avoid lifting objects moving or slipping, especially those vehicle. Make sure to place supports under wheels to avoid the vehicle from slipping, causing the jack to move out of position (Please carefully read the Warning label on the operation handle).
3. Always respect production requirement and use the equipment within the scope of jacking capacity.
4. Use clean and dry air pressure. its application scope should be 90-130 psi and at the same time to apply the filtered & clean 32w hydraulic oil. (The MAX. air pressure of safety valve is 130 psi)

ATTACHMENT:

1. The equipment is assembled with long extension rod and middle extension rod together. Please fix them tightly with rope during the course of transportation to avoid damaging the host.
2. The operation handle is packed in another carton. Please take it out and install it in the host according to the installation indication of operation rod.

EXPLODED VIEW:

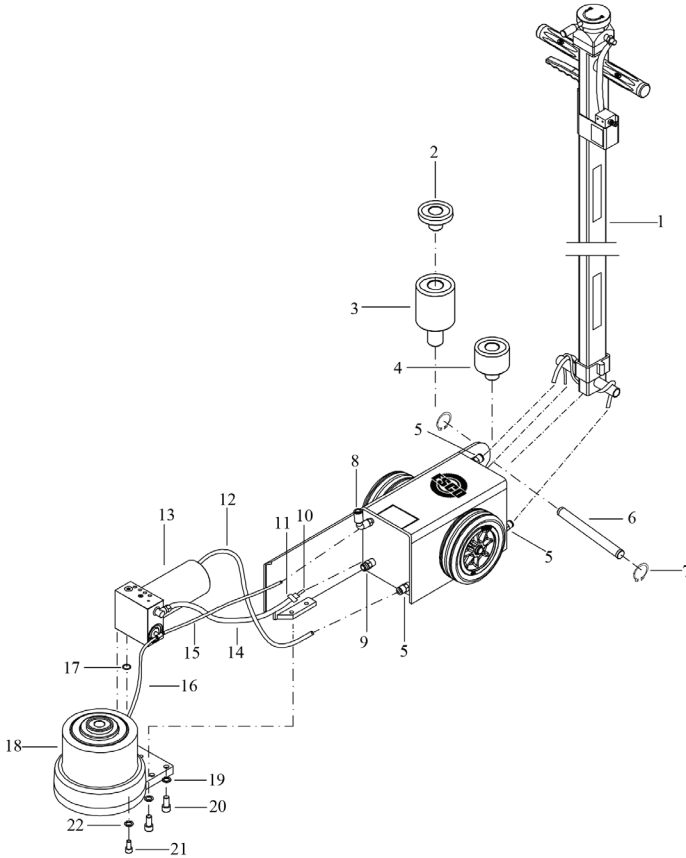

Code	No.	PART NAME	QTY	Code	No.	PART NAME	QTY	Code	No.	PART NAME	QTY
1	NG1300	Operation Rod	1	9	Z9	Adaptor	1	17	M7	O Ring	3
2	02001	Extension Rod 20mm	1	10	Z17	Adaptor	2	18	50T3N-1	50T3N Oil Cylinder	1
3	02004	Extension Rod 80mm	1	11	J20	Lock Code	2	19	J6	M10 Spring Gasket	4
4	02003	Extension Rod 40mm	1	12	Q1	Windpipe	1	20	J4	M10 Screw	4
5	Z8	Adaptor	3	13	D80	Boosting System-D80	1	21	J3	M8 Spring Gasket	4
6	NG2	Fixed shaft	1	14	Q10	Oil Pipe	1	22	J5	M8 Screw	4
7	J18	Outer Retainer Ring	2	15	Q2	Windpipe	1				
8	Z10	Adaptor	1	16	Q3	Windpipe	1				

CYLINDER BREAKDOWN:

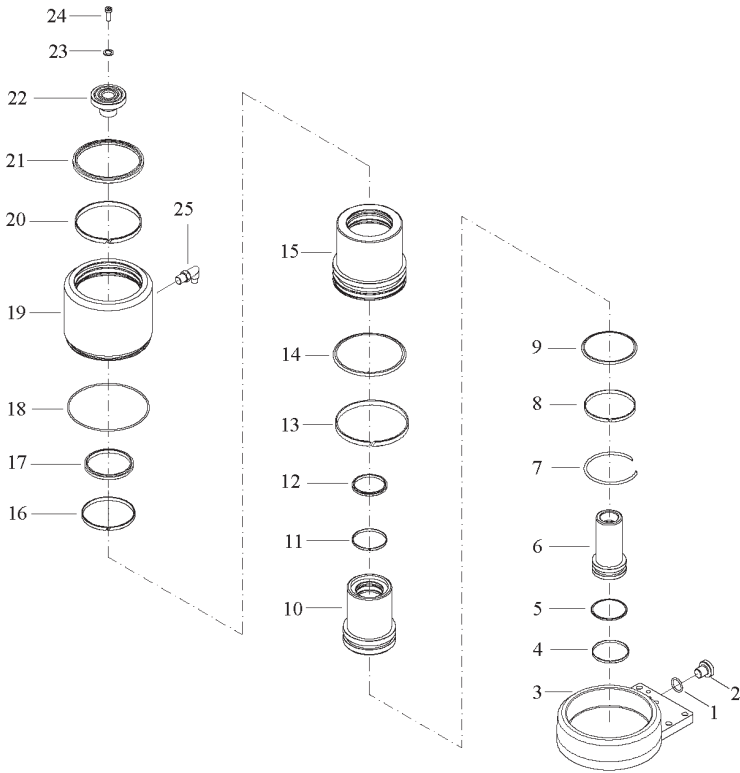

Code	No.	PART NAME	QTY	Code	No.	PART NAME	QTY	Code	No.	PART NAME	QTY
1	M9	O Ring	1	10	N022	15TN Oil Cylinder	1	19	N020	50TN Oil Cylinder	1
2	W6	Screw-plug	1	11	ZG1	15TN Wearing Ring	1	20	ZG10	50TN Wearing Ring	1
3	N024	50TN Bottom	1	12	H50	Dustband	1	21	H125	Dustband	1
4	ZS9	15TN Wearing Ring	1	13	ZS3	50TN Wearing Ring	1	22	N025	Short Extension Rod	1
5	HS8	Glyd Ring	1	14	HS11	Glyd Ring	1	23	J5	M8 Spring Gasket	1
6	N023	15TN Piston	1	15	N021	30TN Oil Cylinder	1	24	J7	Screw	1
7	W53	30TN Retaining Ring	1	16	ZG9	30TN Wearing Ring	1	25	Z7	Adaptor	1
8	ZS10	30TN Wearing Ring	1	17	H85	Dustband	1				
9	HS9	Glyd Ring	1	18	M27	O Ring	1				

MAIN FRAME:

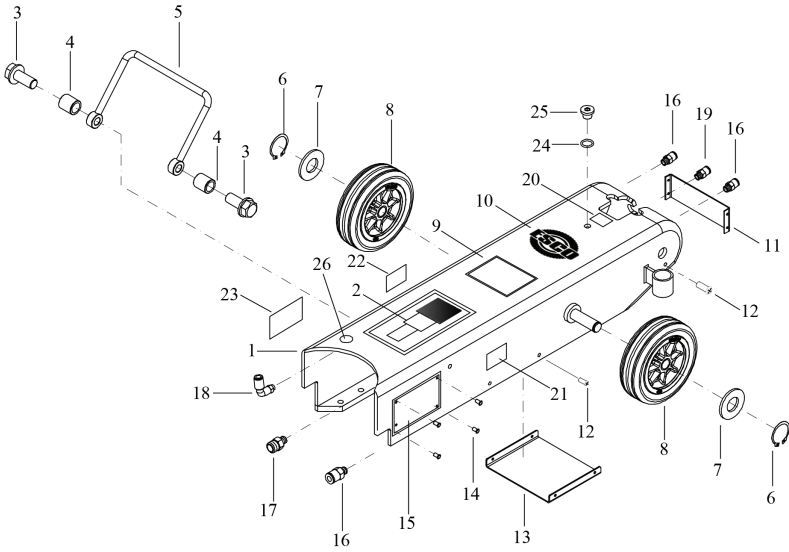

Code	No.	PART NAME	QTY	Code	No.	PART NAME	QTY
	1	N026 Frame	1	14	J11	Nail	4
	2	B3 Label	1	15	B41	Nameplate	1
	3	J9 Screw	2	16	Z8	Adaptor	3
	4	N012 Screw-Plug	2	17	Z9	Adaptor	1
	5	N011 Handle	1	18	Z10	Adaptor	1
	6	J10 Outer Retainer Ring	2	19	Z11	Adaptor	1
	7	N010 Truckle Gasket	2	20	B2	Label	1
	8	W19 Truckle	2	21	B8	Label	1
	9	B4 Label	1	22	B7	Label	1
	10	B43 Label	1	23	B9	Label	1
	11	N008 Protected plate	1	24	M8	O Ring	1
	12	J8 Screw	8	25	W5	Screw-plug	1
	13	N009 Protected Plate	1	26	B10	Label	1

OPERATING ROD:

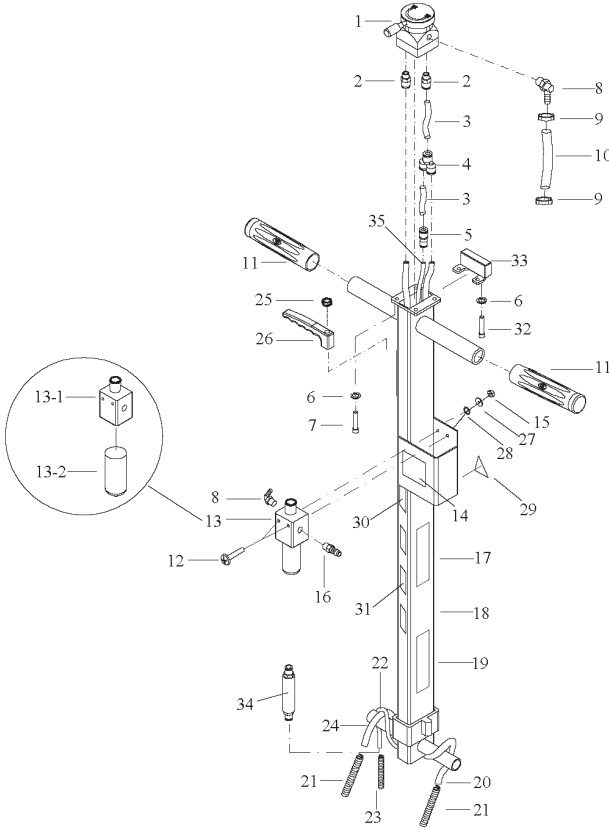

Code	No.	PART NAME	QTY	Code	No.	PART NAME	QTY	Code	No.	PART NAME	QTY
1	TV-04	Hand Valve	1	13-1	W24-1	Valve Body	1	25	J19	Screw	1
2	Z13	Adaptor	2	13-2	W24-2	Glass	1	26	NG3	Handle	1
3	Q6	Windpipe	2	14	B13	Filter Instruction	1	27	J16	Spring Gasket	2
4	Z16	Adaptor	1	15	J17	M5 Bolt	2	28	J15	Gasket	2
5	Z15	Adaptor	1	16	14020	Adaptor	1	29	B17	Label	1
6	J15	Spring Gasket	3	17	B12	Label of Caution	1	30	B15	Label	2
7	J14	Screw	1	18	NG1	Frame of Operation Rod	1	31	B16	Label	6
8	Z12	Adaptor	2	19	B11	Instruction	1	32	J12	Screw	2
9	J20	Lock Code	2	20	Q5	Windpipe	1	33	NG4	Bumper of operation rod	1
10	Q4	Oil Pipe	1	21	W22	Spring tube	2	34	TV5	Oil mist resistance pot	1
11	W25	Handle Cover	2	22	Q8	Windpipe	1	35	Q7	Windpipe	1
12	J13	Screw	2	23	W21	Spring tube	1				
13	W24	Filter	1	24	Q9	Windpipe	1				

BOOSTING SYSTEM:

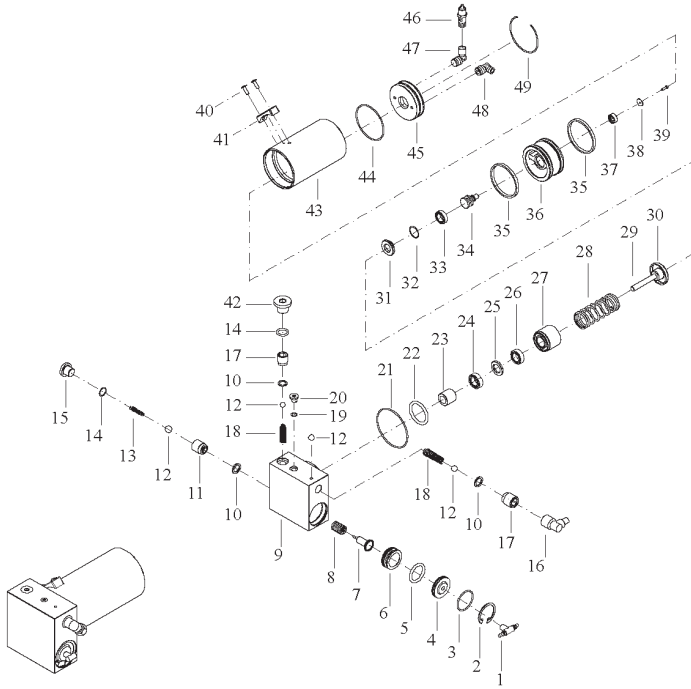

Code	No.	PART NAME	QTY	Code	No.	PART NAME	QTY	Code	No.	PART NAME	QTY
1	Z2	Adaptor	1	18	W11	Spring	2	35	HS1	Glgly Ring	2
2	W14	Retaining Ring	1	19	M9	O Ring	1	36	802	Piston	1
3	M4	O Ring	1	20	W6	Screw-plug	1	37	M12	Sealing Gasket	1
4	813	Piston Cover	1	21	M3	O Ring	1	38	W2	Strengthened Piece	1
5	M5	O Ring	1	22	M6	O Ring	1	39	J1	Screw	1
6	808	Fuel Return Piston	1	23	806	Shaft Sleeve	1	40	J2	Screw	2
7	812	Fuel Return Thimble	1	24	M1	IDI-11.2*21.2*8	1	41	W1	Vent Cover	1
8	W9	Fuel Return Spring	1	25	805	Pump Gasket	1	42	W7	Screw-plug	1
9	807	Hydraulic Intergration	1	26	M2	IDI-11.2*19.2*5	1	43	801	Boosting cylinder	1
10	W3	Gasket	3	27	804	Hydraulic Pump	1	44	M11	O Ring	1
11	814	Screw-plug	1	28	W8	Spring	1	45	811	Cover	1
12	W13	Steel Ball	4	29	W4	Piston rod	1	46	Z5	Safe Valve	1
13	W10	Spring	1	30	803	Cover	1	47	Z4	Adaptor	1
14	M8	O Ring	2	31	810	Cover	1	48	Z1	Adaptor	1
15	W5	Screw-plug	1	32	M10	O Ring	1	49	W12	Retaining Ring	1
16	Z3	Adaptor	1	33	M13	Sealing kit	1				
17	815	Screw-plug	2	34	809	Piston	1				



"Providing Quality Hydraulic Repair and Technical Support for All Your Hydraulic Product Needs"

GUARANTEED 1 Day Turnaround Service.

Received by ESCO - Repaired in 24 Hours - Returned to You!

- ▶ ESCO will pick up product for repair/warranty at your location.
- ▶ ESCO will guarantee Repair/Service for 30 days.
- ▶ ESCO has rental tools available
- ▶ ESCO repairs IMT, FEC, Stellar, Blackhawk, OTC, Power Team, Ame Int., & Enerpac hydraulic pumps, bead breaker, and cylinders.
- ▶ Authorized ESCO Repair & Warranty Centers Located through the US & Canada. For more information contact your ESCO sales representative.

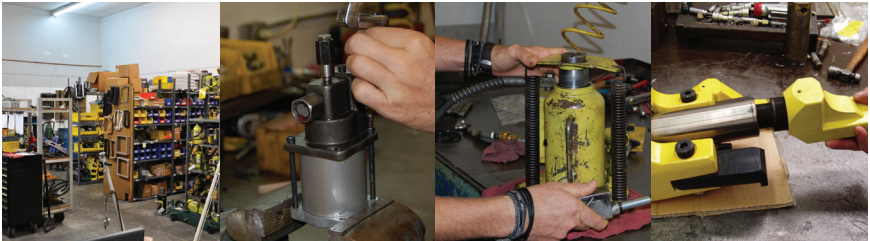

Prompt, reliable service after the sale is very important to ESCO. ESCO maintains an in-house repair facility in Brooksville, Florida. To insure that our customers have as little down-time as possible, we offer a 1 day turnaround service. Our factory repair service is equipped with all the tools and machinery needed to repair your equipment quickly and affordably. Our trained technicians are the best in the industry. Not only do we service our own products, but we also service our competitors' products.

In addition to ESCO's 30 years of providing quality repair service, ESCO has reached out and partnered with more than 50+ hydraulic repair facilities across the US & Canada, to deliver quality repair and timely return of products.

If you have a bead breaker, ram, or hydraulic pump that needs repair, ESCO fixes your product with factory parts and guarantees the repair. In addition to servicing ESCO brand products, we also repair CP, IMT, Elrick, Branick, Goodyear, FEC, Ame Int., and Haltec lines of hydraulic bead breakers, rams, pumps, jacks, and many other hydraulic tire service equipment.

OTHER PRODUCTS AVAILABLE THROUGH ESCO



Tire Spreaders • Tire Inflation Cages • Torque Tools • Tire Inflators

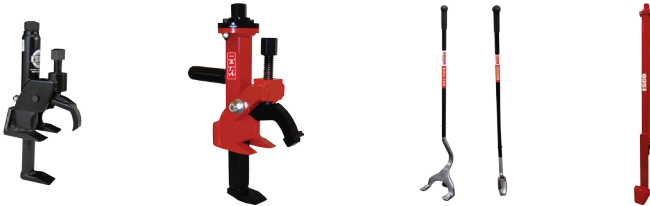

Manual & Pneumatic Bead Breakers • Manual Tire Demounting Tools



Bead Holders • Air Inflation Hoses • Pneumatic Torque • Balancing Beads



Air Hydraulic Bottle Jacks • Cribbing • Jack Support Plates



Wheel Weight Hammers • Valve Stem Pullers • Tire Lube • Wheel Attaching Parts