



# OPERATOR'S MANUAL

## Model #10448



**22TON**  
**HIGH VERSION AIR SERVICE JACK**

## Main data of 22Ton High Version Air Service Jack

LIFTING CAPACITY	MIN. HEIGHT	MAX. HEIGHT	N.W.	G.W.	PACKAGE SIZE	AIR PRESSURE
22 Ton	8.27"	20.67"	101.41 lbs	110.23 lbs	2.6 x 1.42 x 1.1"	101.5-145 psi

### OWNER/OPERATOR RESPONSIBILITY

It is the owner/operator responsibility to properly use and maintain this equipment and the legibility of all warnings and instruction labels. Carefully read and understand the instructions and warnings in this manual before operating this equipment. Keep this manual in a safe location for future reference.



### WARNING

**FAILURE TO HEED THESE WARNINGS MAY RESULT IN PROPERTY DAMAGE AND OR PERSONAL INJURY.**

- Support load by appropriate means after lifting
- Do not exceed rated capacity.
- Center load on the jack.
- Only use attachments and/or adapters supplied with or sold specifically for the jack.
- Only lift areas of the vehicle designated by the vehicle manufacturer.
- Use as lifting device only.
- Use only on hard, level surface.
- Do not modify jack.

### INSPECTION

Prior to each use, visually inspect for leaking hydraulic oil, damaged, loose or missing parts. If jack is worn or damaged remove from service and contact your nearest service center for repair.

### OPERATION

1. Tightly close the release valve knob (located on top of the "T" handle) by turning it clockwise.
2. Center the load on the jack saddle. Connect the air supply, and squeeze the air valve lever to raise the load.  
Release the air valve lever to stop movement.
3. Transfer the load to support stands.
4. To lower the jack, open the release valve knob by SLOWLY turning it counterclockwise.

*NOTE: To adjust the handle, pull up and then release the lever to lock it in one of three positions.*

### Bleeding The Jack

Air bubbles can become trapped inside the hydraulic system, reducing the efficiency of the jack. Purge air from the system as needed by following these steps:

1. With the jack sitting on its base and the ram retracted, bleed air by opening the release valve.
2. Pump for 10 seconds.

### Pump Prime Instructions

The air/hydraulic pump may lose its prime during shipment or after long periods without use. To prime the pump, follow these steps:

1. Remove the upper cover.
2. Loosen the hex socket bolt one-half turn. See Figure 1.
3. Close the release valve.
4. Operate the air pump while repeatedly tightening and loosening the bolt.
5. When the piston begins to rise, tighten the bolt. Verify that the piston can rise to the maximum height position.

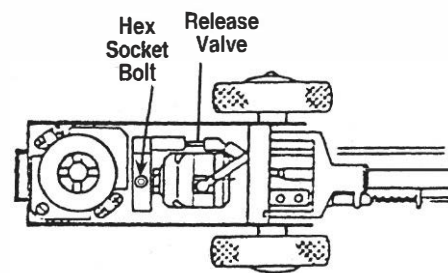

**Figure 1**

### MAINTENANCE

Check oil level. With the jack in an upright position and the ram completely retracted, open the release valve (turn counter-clockwise) and remove the filler plug. The oil level should be just up to the hole. Fill if necessary with clean hydraulic jack oil.

Lubricate internal components. With the release valve open, manually pump the handle six times.

Keep the jack clean. Occasionally lubricate the handle socket pivot point, extension screw, release screw thread, and air valve to prevent corrosion.

# TROUBLE SHOOTING

Problem	Cause	Solution
<b>Erratic Action</b>	<ol style="list-style-type: none"> <li>1. Air in system</li> <li>2. Viscosity of oil too high</li> <li>3. Ram sticking or binding</li> <li>4. Internal leakage in ram</li> </ol>	<ol style="list-style-type: none"> <li>1. With jack sitting on its base and ram retracted, bleed air by opening release valve. Pump for 10 seconds.</li> <li>2. Change to a lower viscosity oil.</li> <li>3. Look for dirt, gummy deposits, leaks, misalignment, worn parts, or defective packing.</li> <li>4. Replace worn packings. Look for excessive contamination or wear.</li> </ol>
<b>Ram does not advance</b>	<ol style="list-style-type: none"> <li>1. Release valve is open</li> <li>2. Low/no oil in reservoir</li> <li>3. Air locked system</li> <li>4. Load is above capacity of system</li> <li>5. Pump lost its prime</li> </ol>	<ol style="list-style-type: none"> <li>1. Close release valve located on top of "T" handle.</li> <li>2. Fill with oil &amp; bleed system.</li> <li>3. With jack sitting on its base and ram retracted, bleed air by opening release valve, running pump for 10 seconds.</li> <li>4. Use correct equipment.</li> <li>5. Follow "Pump Prime Instructions" .</li> </ol>
<b>Ram only extends partially</b>	<ol style="list-style-type: none"> <li>1. Low oil level in reservoir</li> <li>2. Piston rod is binding</li> </ol>	<ol style="list-style-type: none"> <li>1. Fill reservoir with oil, &amp; bleed system.</li> <li>2. Look for dirt, gummy deposits, leaks, misalignment, worn parts, or defective packing.</li> </ol>
<b>Ram advances slowly</b>	<ol style="list-style-type: none"> <li>1. Low air pressure</li> <li>2. Pump not working correctly</li> <li>3. Leaking seals</li> </ol>	<ol style="list-style-type: none"> <li>1. Adjust air pressure to 90–145 psi.</li> <li>2. Rework pump.</li> <li>3. Replace seals.</li> </ol>
<b>Ram advances but doesn't hold pressure</b>	<ol style="list-style-type: none"> <li>1. Release valve is open</li> <li>2. Ram seals are leaking</li> <li>3. Pump check valve not working</li> <li>4. Overload valve leaking or not adjusted</li> </ol>	<ol style="list-style-type: none"> <li>1. Close release valve located on top of "T" handle.</li> <li>2. Replace seals.</li> <li>3. Clean /replace check valve.</li> <li>4. Replace / adjust overload valve.</li> </ol>
<b>Jack leaks oil</b>	<ol style="list-style-type: none"> <li>1. Worn or damaged seals</li> </ol>	<ol style="list-style-type: none"> <li>1. Replace seals.</li> </ol>
<b>Ram will not retract, or retracts slowly</b>	<ol style="list-style-type: none"> <li>1. Release valve is closed</li> <li>2. Reservoir too full</li> <li>3. Ram damaged internally</li> </ol>	<ol style="list-style-type: none"> <li>1. Open release valve.</li> <li>2. Drain oil to correct level.</li> <li>3. Take jack to authorized service center for repair.</li> </ol>

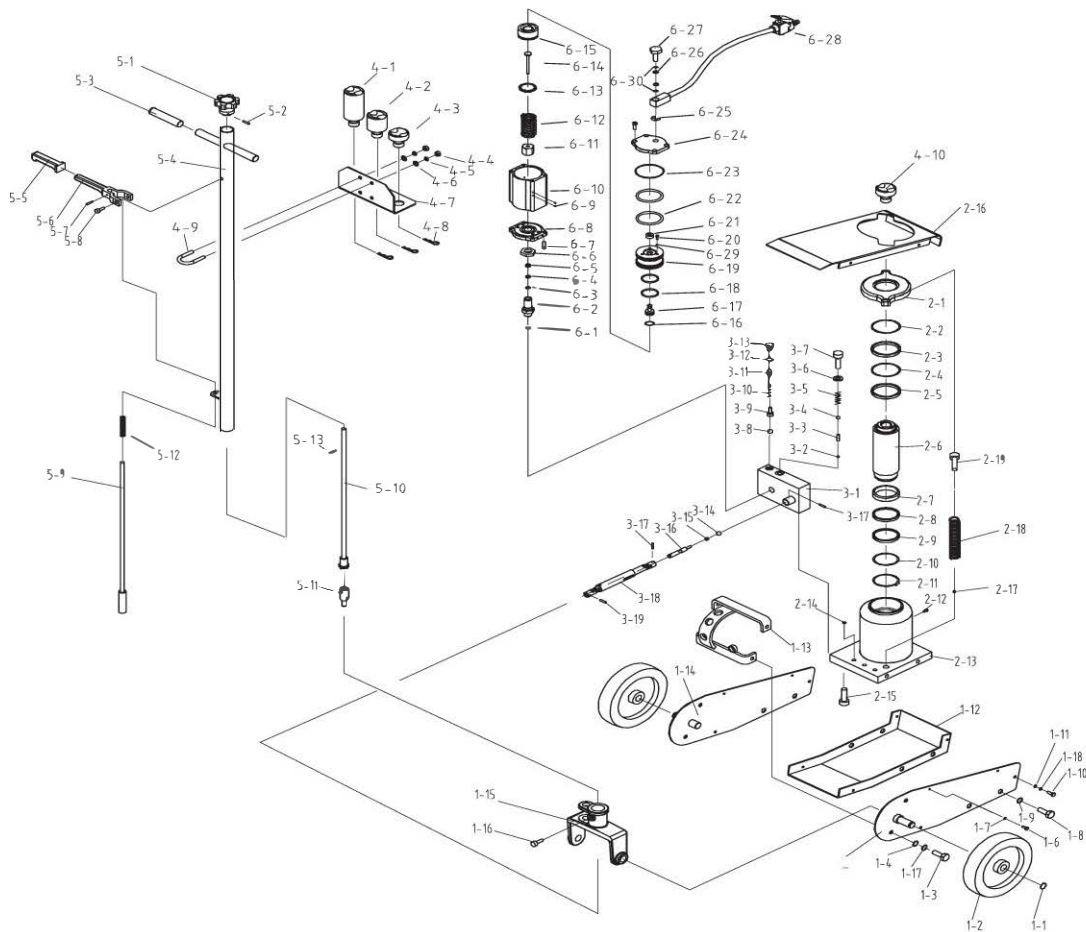

## PARTS LIST

Parts No.	Description	Q'TY	Parts No.	Description	Q'TY
1-1	Retainer	2	3-19	Pin	1
1-2	Wheel Ass'y	2	4-1	Extension Adapter D	1
1-3	Bolt	4	4-2	Extension Adapter C	1
1-4	Washer	4	4-3	Extension Adapter B	1
1-5	Frame Right	1	4-4	Nut	4
1-6	Screw	4	4-5	Washer	4
1-7	Washer	4	4-6	Flat Washer	4
1-8	Bolt	4	4-7	Angle Plate	1
1-9	Washer	4	4-8	Pin	3
1-10	Bolt	4	4-9	U-bolt	2
1-11	Washer	4	4-10	Extension Adapter A	1
1-12	Bed	1	5-1	Knob	1
1-13	Bracket	1	5-2	Pin	1
1-14	Frame Left	1	5-3	Handle Sleeve	2
1-15	Handle Socket	1	5-4	Handle Ass'y	1
1-16	Screw	1	5-5	Sleeve	1
1-17	Lock Washer	4	5-6	Lock Lever	1
1-18	Lock Washer	4	5-7	Pin	2
2-1	Spring Hanger	1	5-8	Screw	2
2-2	Retainer	1	5-9	Control Rod	1
2-3	Bushing	1	5-10	Convey Rod	1
2-4	O-ring	1	5-11	Rod Joint	1
2-5	Bushing	1	5-12	Sping	1
2-6	Piston Rod	1	5-13	Pin	1
2-7	Piston Ring	1	6-1	Copper Washer	1
2-8	Washer	1	6-2	Cylinder Pump	1
2-9	O-ring	1	6-3	Y-sealing Washer	1
2-10	Retainer	1	6-4	Nylon Washer	1
2-11	Retainer	1	6-5	Copper Washer	1
2-12	Oil Filler Plug	1	6-6	Nut	1
2-13	Oil Cylinder Ass'y	1	6-7	Screw	8
2-14	O-ring	3	6-8	Front Cover	1
2-15	Screw	3	6-9	Steel Ball	4
2-16	Cover Board	1	6-10	Air Motor Housing	1
2-17	Nut	2	6-11	Nut	1
2-18	Spring	2	6-12	Sping	1
2-19	Screw	2	6-13	Washer	1
3-1	Valve Bolck	1	6-14	Pump Plunger	1
3-2	Steel Ball	1	6-15	Piston	1
3-3	Spring	1	6-16	O-ring	1
3-4	Steel Ball	1	6-17	Release Air Rod	1
3-5	Spring	1	6-18	O-ring	2
3-6	Copper Washer	1	6-19	Piston cover	1
3-7	Screw	1	6-20	Screw	3
3-8	Steel Ball	1	6-21	Air Seal	1
3-9	Ball Seat	1	6-22	O-ring	2
3-10	Safety Valve Spring	1	6-23	O-ring	1
3-11	Screw	1	6-24	Rear Cover	1
3-12	Sealing Washer	1	6-25	Retainer	1
3-13	Valve Plug Screw	1	6-26	O-ring	2
3-14	Steel Ball	1	6-27	Bolt	1
3-15	Washer	1	6-28	Air Valve Ass'y	1
3-16	Release Valve Rod	1	6-29	O-ring	3
3-17	Pin	1	6-30	Nylon Washer	2
3-18	Universal Joint Assembly	1			