



ESCO EQUIPMENT SUPPLY COMPANY

Manual & Parts List

Tire Bead Breaker

Model #10101

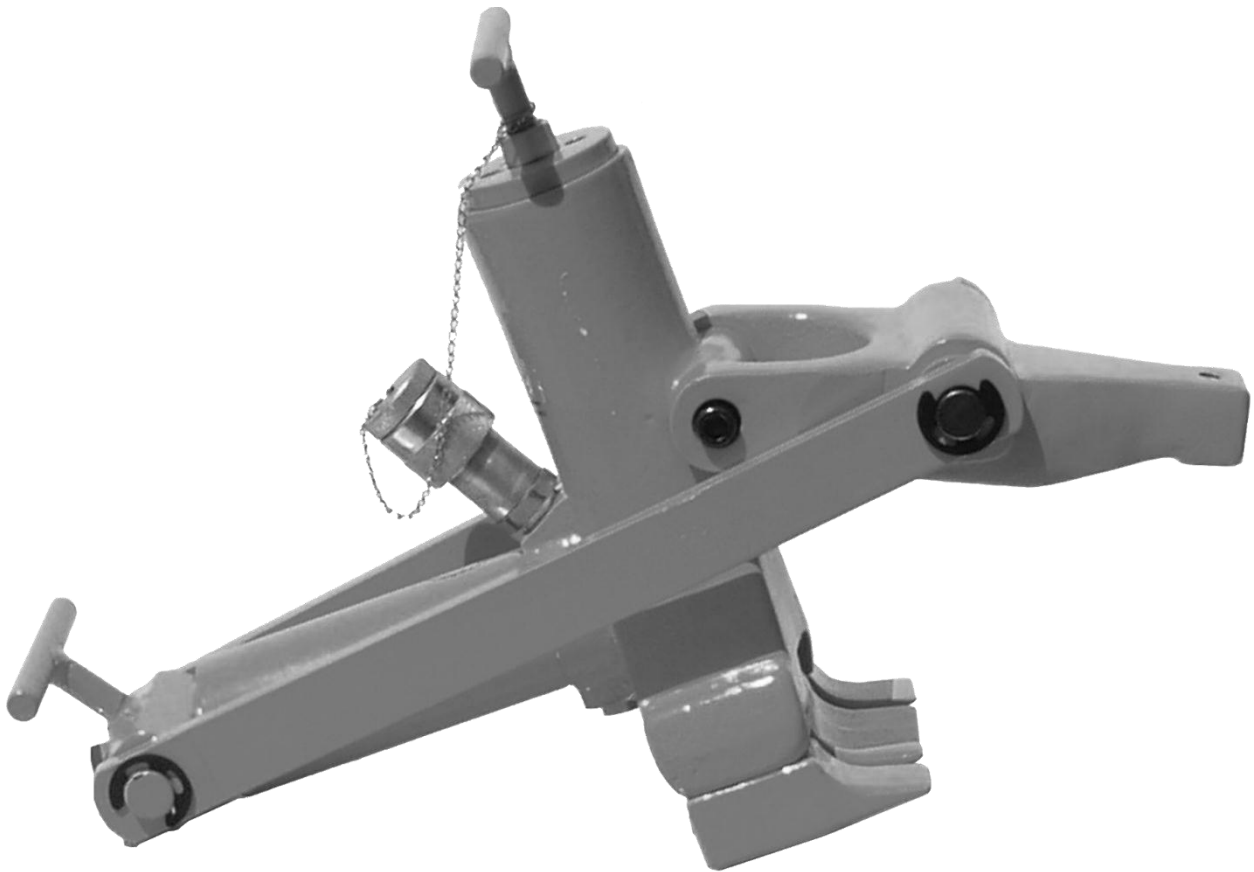



ESCO EQUIPMENT SUPPLY COMPANY

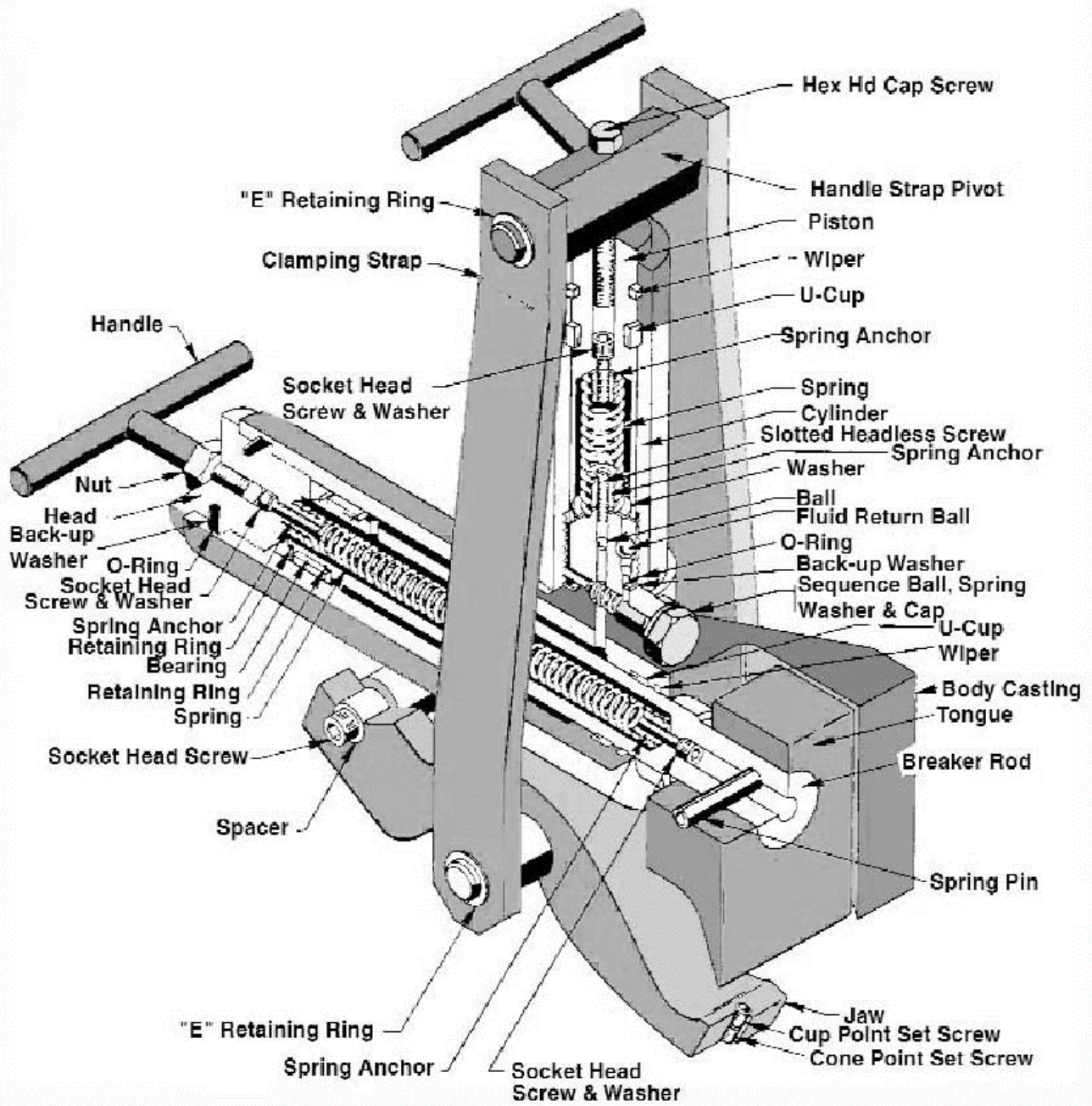



ESCO EQUIPMENT SUPPLY COMPANY

Parts List

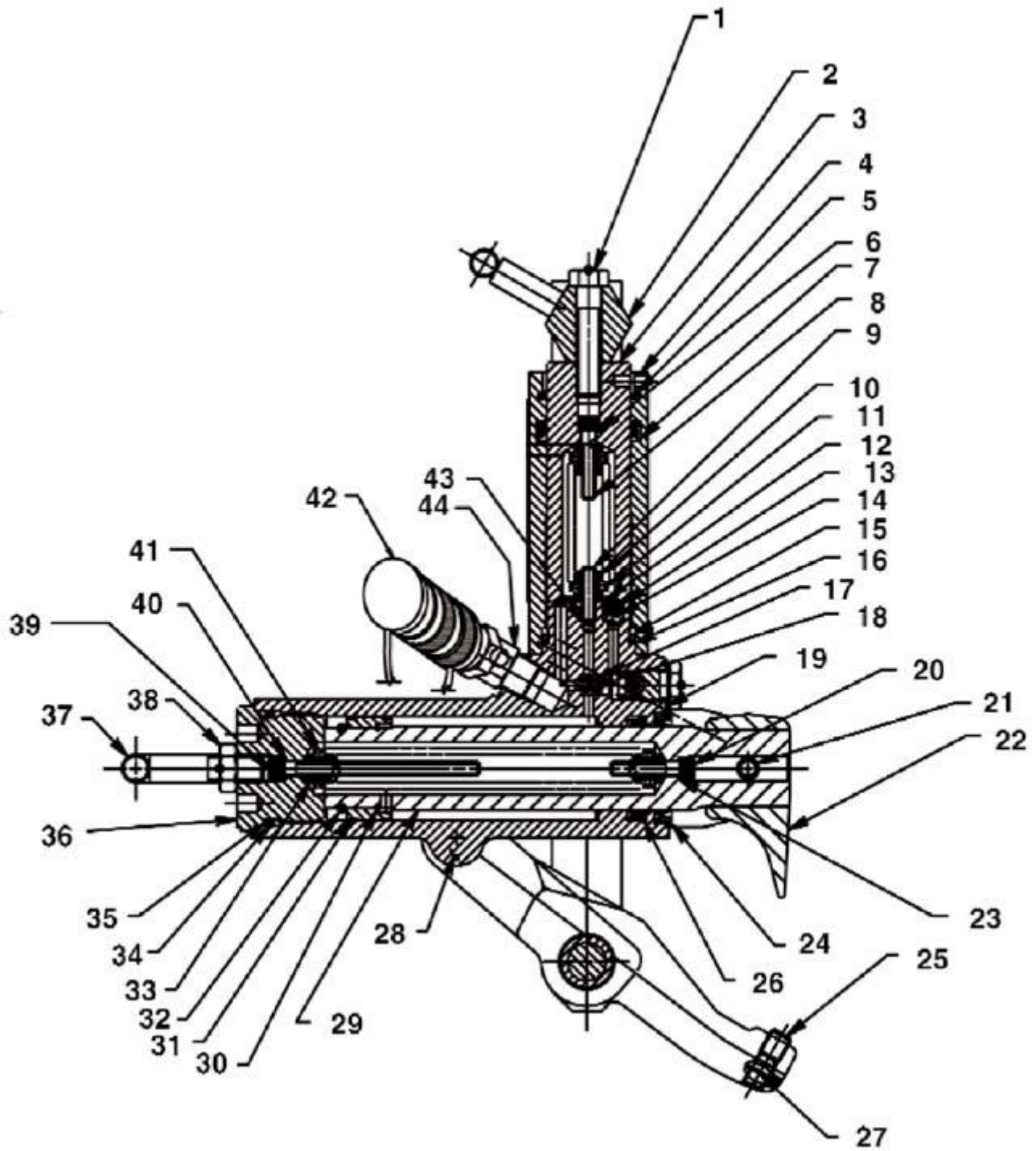



ESCO EQUIPMENT SUPPLY COMPANY

Item No.	Part No.	No. Req'd	Description
1	12901	1	Screw, Hex Hd Cap (7/16-14 x 2) Torque to 30/40 Ft. Lbs
2	36949	1	Handle, Strap Pivot
3	350455	1	Piston, (Single Jaw)
4	350456	1	Body, Cylinder (Single Jaw; Torque to 125/140 Ft. Lbs.)
5		1	Rod Wiper * •
6	10442	1	Washer, Copper *
7		1	U-cup * •
8	10020	1	Screw, Soc Hd (1/4-20 x 1-1/4; Torque to 90/110 in. Lbs.
9	11116 (SEE BC2516027A)	1	Screw, Set (1/4-20 x 1)
10	201360	1	Spring, Retainer
11	201430	1	Spring, (.83 OD x 1.90 x .13 WS)
12	17160 (SEE DA10494167)	1	Washer, Special (1.00 x .26)
13	13944 (SEE DA10492110)	1	Spring, (.36 OD x .50 x .05 WS)
14	10375	1	Ball, (1/4 in. Dia. Steel) *
15		1	O Ring, (1.62 x 1.37 Nitrile) * •
16		1	Washer, Backup (2.00 x 1.75) * •
17	16724	1	Spring, (.32 OD x 1.20 x .08 WS) *
18	10375	1	Ball, (1/4" Dia. Steel) *
19	10261	1	Washer, Copper (.75 x .60) *
20	10020	1	Screw, Soc Hd (1/4-20 x 1-1/4; Torque to 90/110 in. Lbs.)
21	10613	1	Pin, Roll (.38 x 2.25)
22	36853	1	Claw, Machining
23	10442	1	Washer, Copper *
24		1	Wiper, Rod (2.00 x 1.50 URE) * •
25	BC380627B	1	Screw, Set (3/8-16 x 1/2)
26		1	U-cup * •
27	DA11382027	1	Screw, Set (3/8-16 x 3/8)
28	64250	1	Body, Beak Breaker
29	420439	1	Piston, Cylinder
30	204237	1	Ring, Retainer (internal 141 ID)
31	204236	1	Bearing
32	201433	1	Ring, Retainer (internal 1/31 ID)
33	201360	1	Spring, Retainer
34		1	O Ring, (2.00 x 1.75 Nitrile) * •
35		1	Washer, Backup (2.00 x 1.75) * •
36	350457	1	Plug, End (Torque to 140/225 Ft. Lbs.)
37	202636	1	Handle
38	10391	1	Nut, Hex Jam (1/2-13)
39	16064	1	Screw, Soc Hd (1/4-20 x 3-1/2; Torque to 90/110 in. Lbs.)
40	10442	1	Washer, Copper (.37 x .25) *
41	202625	1	Spring, (.83 OD x 5.00 x .13 WS)
42	10606	1	Ram Half Cplr/plastic dust cap
43	12223	1	Ball, (3/16" Dia. Steel)
44	10622	1	Fitting, Elbow 45 Deg (3/8 NPTF)
	*	=	Parts included in kit 10701
	•	=	Parts only available in kit form 10701A



ESCO EQUIPMENT SUPPLY COMPANY

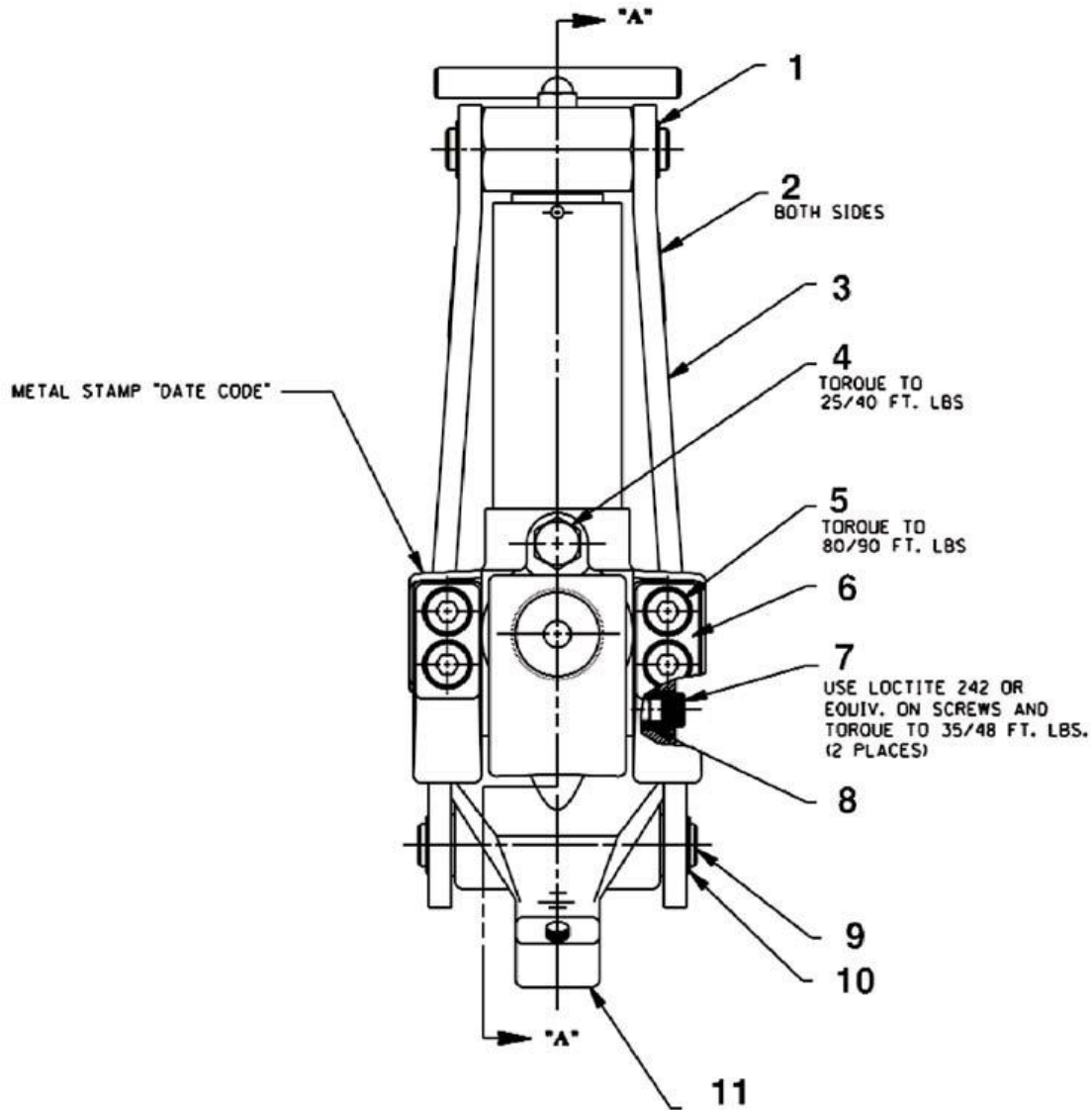

Item No.	No. Req'd	Part No.	Description
1	2	11901	Ring, Retainer External
2	2	20095	Decal, Warning
3	2	350270L	Strap
4	1	DA10482020	Screw, Cap (9/16-18 x 1 -1/8)
5	4	B1139028	Screw, Soc Hd (1/2-13 x 1-1/4)
6	2	306135	Tooth, Replaceable
7	2	B1069028	Screw, Soc Hd (3/8-16 x 1)
8	2	204238	Spacer
9	1	DA10488061L	Pin
10	2	11901	Ring, Retainer External
11	1	420438	Jaw, Single