

ITEM #07701 MANUAL

! WARNING !

To avoid personal injury and/or property damage, please read and follow ALL of these instructions before assembling and operating.

Only use the cargo carrier with a properly installed 1.25" or 2" hitch receiver capable of supporting the Cargo Carrier and its load. Refer to Hitch Manufacturer's specifications and load capacity before using.

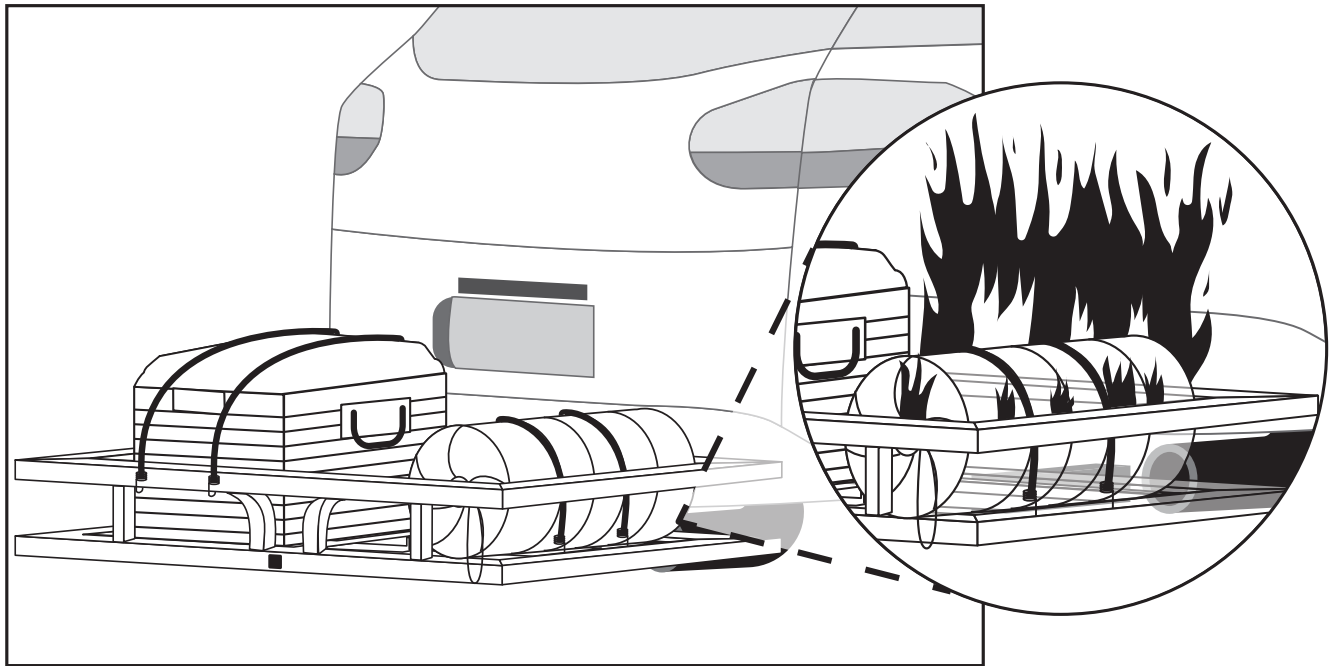

WARNING: Be aware of the risk of fire and damage to property resulting from the vehicle's exhaust system pointing at or running near the cargo loaded on the Cargo Carrier. Before installing the Cargo Carrier, check to make sure that the exhaust pipe is not pointing in

SAFETY WARNINGS AND PRECAUTIONS

 **WARNING:** When using product, basic safety precautions should always be followed to reduce the risk of personal injury and damage to equipment.

Only use the cargo carrier with a properly installed 2 inch or 1.25" hitch receiver capable of supporting the Cargo Carrier and its load. Refer to Hitch Manufacturers specifications and load capacities before using.

Read all instructions before using this product!

1. Keep work area clean. Cluttered areas invite injuries.
2. Observe work area conditions. Keep work area well lighted.
3. Store idle equipment. When not in use, the Carrier must be stored in a safe and clean location. Always lock up products and keep out of reach of children.
4. Use the right product for the job. There are certain applications for which the Cargo Carrier was designed. Do not modify the Cargo Carrier and do not use the Cargo Carrier for a purpose for which it was not intended.
5. Check for damaged parts. Before using any product, any part that appears damaged should be carefully checked to determine that it will operate properly and perform its intended function. Check for any broken or damaged parts and any other conditions that may affect its operation. Replace or repair damaged or worn parts immediately.
6. Replacement parts and accessories. When servicing, use only identical replacement parts. Use of any other parts will void the warranty.
7. Do not exceed the product's maximum load capacity of 300 lbs. Based on evenly distribute weight, CAUTION NOT INTENDED TO BE USED AS A STEP!
8. Only use the Cargo Carrier with a properly installed 2 in. hitch receiver capable of supporting the Cargo Carrier and its load. If the Cargo Carrier is installed on a Class II receiver, total weight, including carrier, is limited to 350 lbs.
9. Use eye protection. Always wear ANSI-approved impact safety goggles when setting up, loading and unloading the Cargo Carrier. Wear gloves and avoid sharp edges when assembling and when loading and unloading the Cargo Carrier.
10. Do not allow children to play on, stand upon or climb into the Cargo Carrier. The Cargo Carrier is not for carrying people or animals.
11. Always check hardware and assembled parts after assembling. All connections should be tight and hardware tightened.
12. Always distribute objects in the Cargo Carrier evenly. Uneven weight distribution could cause tipping.
13. Be aware of dynamic loading! Suddenly dropping or bouncing a load on the Cargo Carrier may create, for a brief instant, an excess load, which may result in damage to the product and/or personal injury. Additionally, if the vehicle hits a bump, a slight play in the receiving hitch or a movement in the load could result in a momentary dynamic loading effect that could dramatically increase the actual weight load. Check the hitch-to-carrier connection for any looseness. This momentary dynamic loading effect could result in damage to the Cargo Carrier, the load and possible personal injury.
14.  **WARNING:** Be aware of the possible risk of fire and damage to property resulting from the vehicle's exhaust system pointing at or running near the cargo loaded on the Cargo Carrier. Before installing the Cargo Carrier, check to make sure that the exhaust pipe is not pointing in the direction of the cargo. Flammable cargo can ignite from exposure to heat. Other cargo can be damaged from the heat. Always be aware of this potential danger, and never use the Cargo Carrier if the risk exists.
15. Follow DOT/MOT guidelines for installation and use.
16. Do not exceed 65 MPH while carrier is attached.

INSTRUCTIONS

Part#	Q'TY	DESCRIPTION	Part#	Q'TY	DESCRIPTION
1	1	1.25" TUBE ASSEMBLY	9	4	FLAT WASHER M10
2	1	FRAME,LEFT	10	4	LOCK NUT M10
3	1	FRAME,RIGHT	11	1	1/2" BOLT
4	2	CROSS BRACE	12	1	1/2" SPRING WASHER
5	8	BOLT M8*35MM	13	1	1/2" FLAT WASHER
6	8	FLAT WASHER M8	14	1	2" PLASTIC ADAPTER
7	8	LOCK NUT M8	15	1	CLIP
8	4	CONNECTING BOLT M10*60MM			

1. Unpack all parts and identify according to the part list and illustration.
 2. Install bolts (8) through left frame (2), tube assembly (1), and right frame (3). Install flat washers (9), and lock nuts (10) on the bolts (8).
- *CAUTION:** Do not tighten bolts until installation of the cross brace is complete.*
3. Place the cross braces (4) onto the frame. Install all eight bolts (5) into the cross braces and frame. Install flat washers (6) and nuts (7) on the bolts (5), then tighten them together.
 4. Install 2" plastic adapter (14) on the 1.25" tube assembly (1), then install the cargo carrier into the hitch receiver, secure with 1/2" bolt (11), 1/2" spring washer (12), 1/2" flat washer (13) and clip.

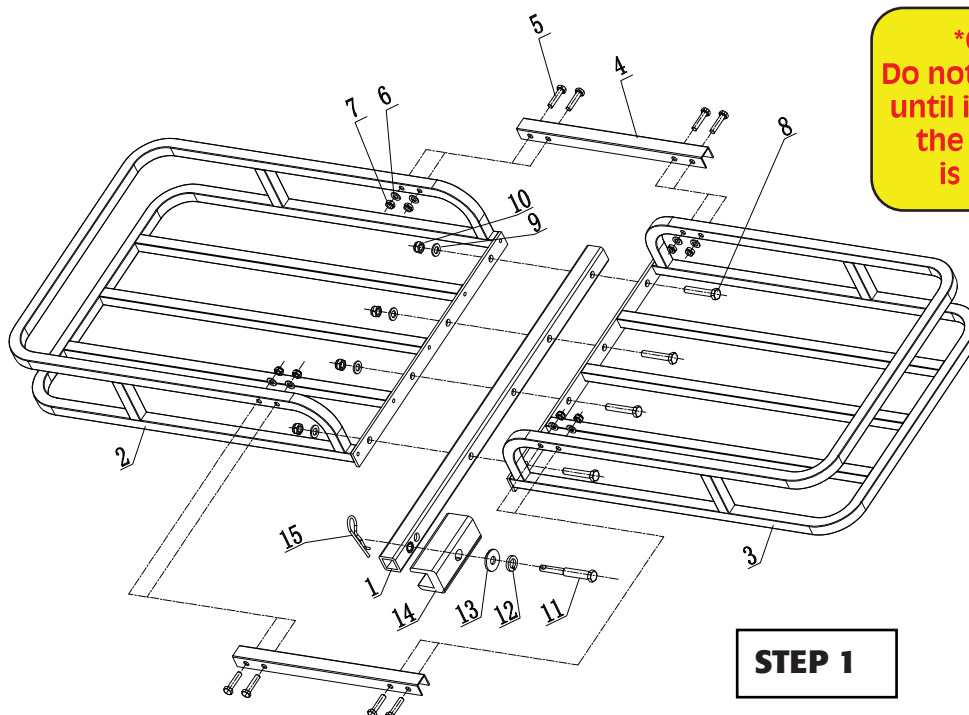

STEP 2

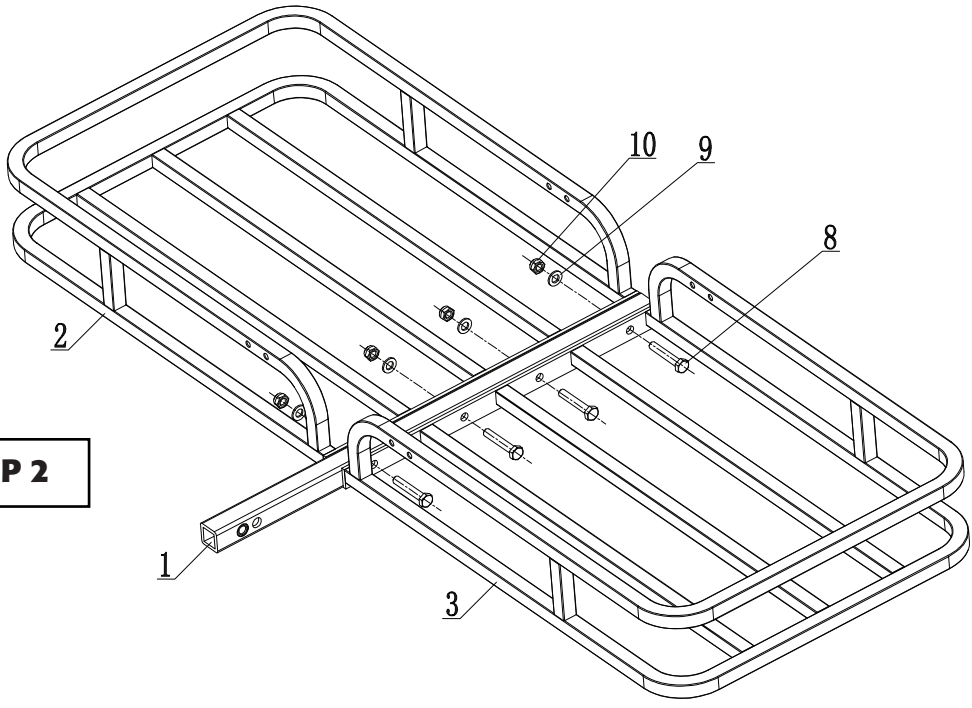

STEP 3

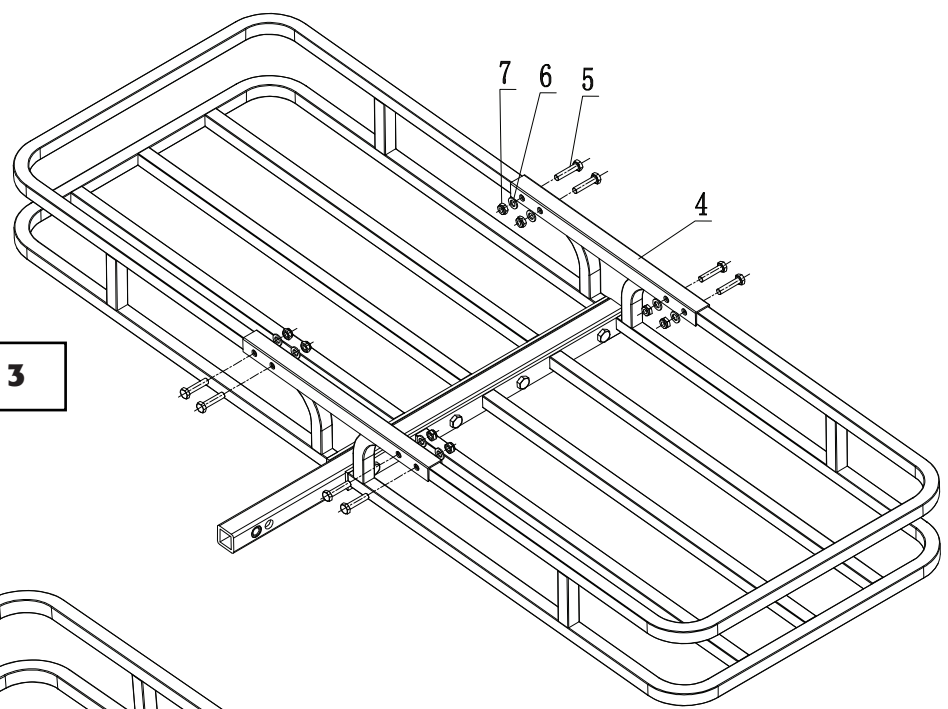

STEP 4

