

2021

*The Name You Trust For Engine Parts*



Since 1987

EngineQuest®

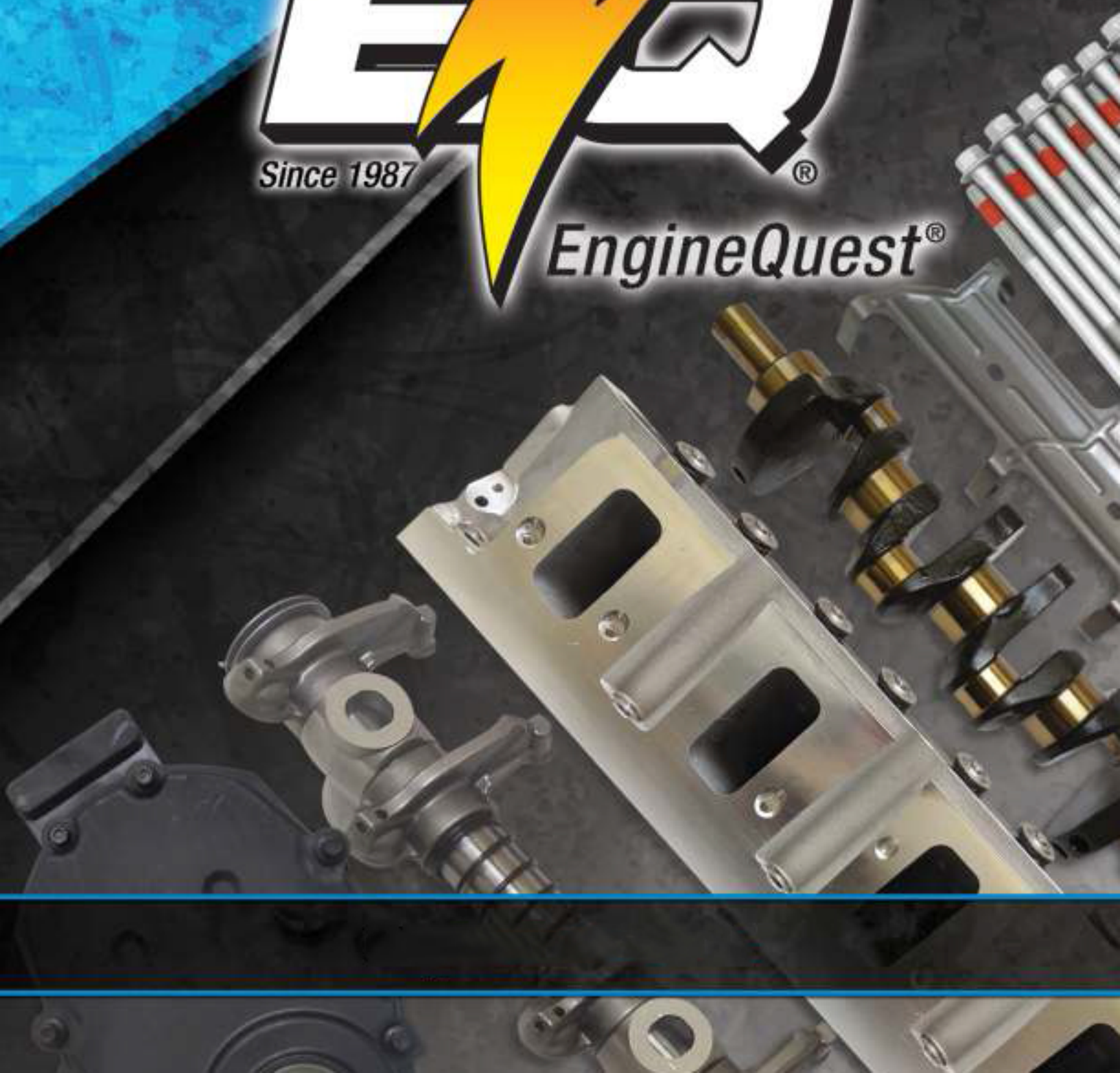



## The Engine Parts, Cores, & Recycling Partner You Can Count On, Now and Into The Future

EngineQuest and EQ Cores & Recycling has served the engine and transmission remanufacturing market for over 70 years.

EngineQuest has provided remanufacturing solutions since 1987. We specialize in hard-to-find or hard-to-salvage parts, as well as parts that make one item work in a different application.

In the restoration market, EngineQuest has become a leader in making replacement parts that OEMs have obsoleted, such as the FE Ford Rocker Assembly, V8 Pontiac Timing Cover, and Small Block Chevy Oil Filter Adaptor. We continue to expand our product line, which now includes our two newest items – replacement Crankshaft Sleeves for the FE Ford and 429/460 Ford engines.

For hard-to-salvage items, it often means buying from the OEM, where the prices might not be logical, or the OE doesn't sell the part you actually need. EngineQuest will make these items so our customers can get what they need, for the best possible price, when and how they need it. This includes LS Chevy Oil Galley Plugs, Valve Cover Bolts, Head Bolt Sets, and many others.

EQ Cores & Recycling was part of A&A Midwest, which began selling engine & transmission cores in 1949. In 2020, the Las Vegas location became EQ Cores & Recycling. Over the years, the product line has grown to include engine component cores, as well as transfer cases, and torque converters. With nearly 10,000 engines, 2,000 transmissions, and thousands of component parts in stock, EQ Cores & Recycling is ready to serve your core needs.

When our buyers are working with auto salvage yards, we buy their scrap items, such as radiators, batteries, harness wire, and aluminum wheels. In addition, we serve the Las Vegas local business community for their scrap metal recycling needs. By specializing in automotive and non-ferrous scrap, we can offer our customers better prices, as well as top-notch service, which has allowed us to become one of the largest business-to-business recyclers in the west.

**Our team looks forward to continuing to serve you, now and into the future.**



# THE NAME YOU TRUST FOR ENGINE PARTS

## TABLE OF CONTENTS

| PRODUCT                                  | PAGE #      | PRODUCT                               | PAGE #        |
|------------------------------------------|-------------|---------------------------------------|---------------|
| BALANCE SHAFT ELIMINATION KITS           | 23          | INTAKE MANIFOLD PLUG KIT              | 24, 36        |
| BLOCK CONVERSION JIGS                    | 23          | INTAKE MANIFOLDS                      | 24, 37        |
| BLOCK OFF PLATES                         | 17, 37      | INTERCHANGES, OEM PART NUMBER         | 38, 39        |
| CAM ECCENTRICS                           | 16          | JAPANESE THREAD PIPE PLUGS            | 21            |
| CAM THRUST PLATES                        | 23          | JET VALVE ELIMINATION KITS            | 23            |
| CAMSHAFT BOLT                            | 17          | MANIFOLDS, EXHAUST                    | 24            |
| CAPS AND GROMMETS                        | 31          | MANIFOLDS, INTAKE                     | 24, 37        |
| CONNECTING ROD                           | 22          | MARINE COMPONENTS                     | 31-37         |
| CONVERSION JIGS                          | 23          | METRIC PIPE PLUGS                     | 21            |
| CONVERSION REAR MAIN SEAL ALIGNMENT TOOL | 22          | OEM PART NUMBER INTERCHANGE           | 38, 39        |
| CONVERSION REAR MAIN SEAL HOLDERS        | 22          | OIL BAFFLE                            | 19, 32        |
| CRANKSHAFT REPLACEMENT SLEEVES           | 17          | OIL CAP                               | 20            |
| CRANKSHAFTS                              | 17          | OIL FILTER ADAPTERS                   | 18, 33        |
| CYLINDER HEAD, ADAPTORS                  | 23          | OIL GALLEY PLUGS                      | 16            |
| CYLINDER HEADS, 23 DEGREE                | 13          | OIL PAN RAIL SET                      | 19, 33        |
| CYLINDER HEADS, AMC                      | 5, 6        | OIL PANS                              | 19, 33        |
| CYLINDER HEADS, CHEVROLET                | 6-8, 13, 34 | PCV GROMMETS                          | 20            |
| CYLINDER HEADS, CHRYSLER                 | 8, 9        | PIPE PLUGS                            | 21            |
| CYLINDER HEADS, FORD                     | 9, 10       | ROCKER ARM GUIDE PLATES               | 14            |
| CYLINDER HEADS, FORKLIFT                 | 12, 13      | ROCKER ARM GUIDE PLATE CONVERSION KIT | 14            |
| CYLINDER HEADS, INDUSTRIAL               | 12, 13      | ROCKER ARM VALVE COVERS               | 31            |
| CYLINDER HEADS, ISUZU                    | 10          | ROCKER SHAFT ASSEMBLY                 | 15            |
| CYLINDER HEADS, JEEP                     | 5, 6        | ROLLER LIFTER GUIDES & RETAINERS      | 15, 37        |
| CYLINDER HEADS, MARINE                   | 34, 35      | SCREW IN STUDS                        | 13, 35        |
| CYLINDER HEADS, MAZDA                    | 11          | SIDE COVER - PUSH ROD                 | 24, 36        |
| CYLINDER HEADS, MITSUBISHI               | 11          | SMOG PLUGS                            | 22            |
| CYLINDER HEADS, NISSAN                   | 11          | STANDARD PIPE PLUGS                   | 21            |
| CYLINDER HEADS, PERFORMANCE              | 13          | STUDDER MAIN BOLT                     | 19            |
| CYLINDER HEADS, SCREW IN STUDS           | 13, 35      | SYSTEM COOLANT PLUGS                  | 16            |
| CYLINDER HEADS, TOYOTA                   | 12          | TIMING COVERS                         | 20, 25-28, 32 |
| DIPSTICK TUBE ADAPTORS                   | 22          | TIMING COVERS, AMC                    | 25            |
| DIPSTICK TUBES                           | 20          | TIMING COVERS, BUICK                  | 25            |
| DOWEL PINS                               | 15          | TIMING COVERS, CHEVROLET              | 25, 26        |
| ELIMINATION KITS                         | 23          | TIMING COVERS, CHRYSLER               | 26            |
| EXHAUST MANIFOLDS                        | 24          | TIMING COVERS, DODGE                  | 26            |
| FUEL PUMP BLOCK OFF PLATES               | 17          | TIMING COVERS, FORD                   | 27            |
| GUIDE PLATES                             | 34          | TIMING COVERS, ISUZU                  | 27            |
| HARMONIC BALANCER                        | 17, 36      | TIMING COVERS, JEEP                   | 25            |
| HARMONIC BALANCER REPLACEMENT SLEEVES    | 17          | TIMING COVERS, MARINE                 | 32            |
| HEAD BOLTS, CHEVROLET                    | 29          | TIMING COVERS, MOPAR                  | 26            |
| HEAD BOLTS, CHRYSLER                     | 29          | TIMING COVERS, PONTIAC                | 28            |
| HEAD BOLTS, DODGE                        | 29          | TIMING COVERS, TOYOTA                 | 28            |
| HEAD BOLTS, FORD                         | 30          | TIMING MARKERS                        | 20            |
| HEAD BOLTS, JEEP                         | 30          | TINWARE                               | 20            |
| HEAD BOLTS, MARINE                       | 36          | TRUNNION STYLE ROCKER ARM SET         | 4, 14         |
| HEAD BOLTS, MAZDA                        | 30          | VALVE COVER BOLT SET                  | 4, 16         |
| HEAD BOLTS, MITSUBISHI                   | 30          | VALVE COVERS                          | 20            |
| HEAD BOLTS, TOYOTA                       | 30          | WATER OUTLET TUBE                     | 16            |
| HEAD GASKET SETS                         | 14          | WINDAGE TRAY                          | 19, 32        |

The information in this catalog is from reliable sources and has been compiled with the utmost care; however, we cannot be held responsible for errors. Listing in this catalog does not guarantee availability.

## NEW LS PARTS

### VALVE COVER BOLT SET

| PART #     | DESCRIPTION                              |
|------------|------------------------------------------|
| EQ-VCB294N | FITS ALL LS3 AND LATER ENGINES, SET OF 8 |

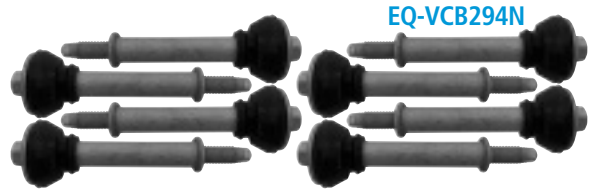

EQ-VCB294N

### TRUNNION STYLE ROCKER ARM SET

| PART #    | DESCRIPTION                                                                                               |
|-----------|-----------------------------------------------------------------------------------------------------------|
| EQ-RA294P | UPGRADED TRUNNION STYLE ROCKER ARM SET FOR ALL LS3 AND LATER ENGINES, 1.7 ROCKER RATIO, 16 PIECES PER SET |



EQ-RA294P

## We've Got The Components You Need For Your LS Build!

### CYLINDER HEADS - BARE & ASSEMBLED

Pages 6 - 8



EQ-CH364A / EQ-CH364AA



EQ-CH364B / EQ-CH364BA

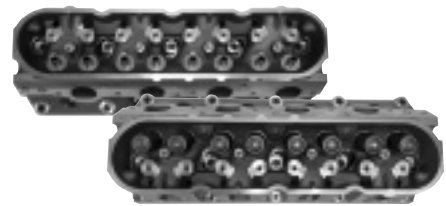

EQ-CH364C / EQ-CH364CA

### ROLLER LIFTER GUIDES/BOLTS

Page 15



EQ-RLR294N & EQ-RLB294N

### OIL GALLEY PLUGS

Page 16



EQ-OGP294N

### SYSTEM COOLANT PLUGS

Page 16

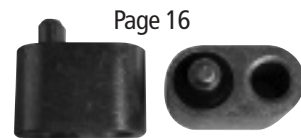

EQ-BP085N

### OIL FILTER ADAPTERS

Page 18



EQ-OFA294B

EQ-OFA294A

### HEAD BOLT SETS

Page 29

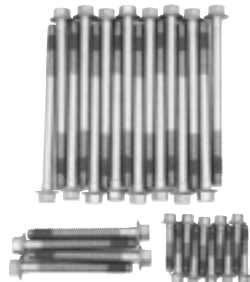

EQ-HB349NA

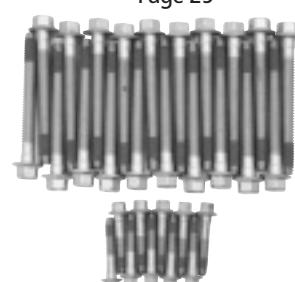

EQ-HB349NB

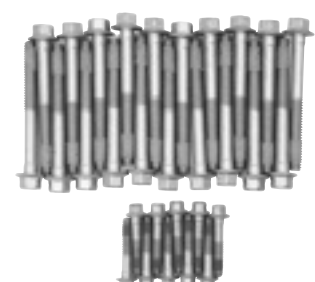

EQ-HB349NC

## CYLINDER HEADS

### EQ offers bare and fully loaded cylinder heads!

#### EQ bare heads

ready to install the drive train,  
no porting or polishing needed!

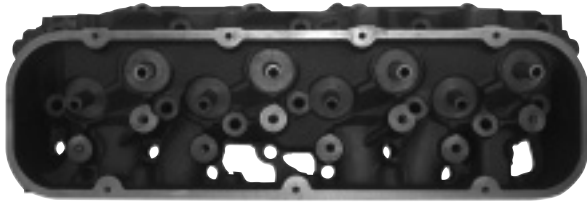

EQ-CH454C

#### EQ loaded heads

include **100% New** OE type stainless steel  
valves, seals, valve springs, and retainers



EQ-CH364CA

### All EQ cylinder heads outperform their competitors!

- The highest grade cast iron and aluminum
- Thicker deck for greater strength
- Improved design resists cracking
- Superior port finish for increased flow
- Water flow redesigned for greater thermal conductivity
- Hardened exhaust seats
- CNC machined guides and seats
- 25-point quality check on every head
- 3-angle valve finish
- Competitive pricing

## AMC / JEEP CYLINDER HEADS

EQ-CH150NA

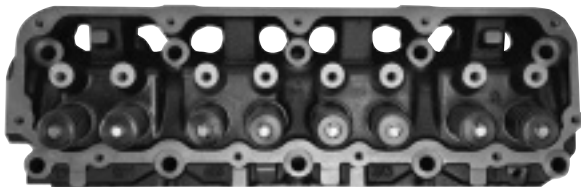

EQ-CH242N



| PART #      | CID | LITER | YEARS       | NOTES                                                                                                           |
|-------------|-----|-------|-------------|-----------------------------------------------------------------------------------------------------------------|
| EQ-CH150N   | 150 | 2.5   | 1987 - 2002 | REPLACES CASTING NUMBERS: 2403, 117, 1/2" HEAD BOLT                                                             |
| EQ-CH150NA  | 150 | 2.5   | 1987 - 2002 | REPLACES CASTING NUMBERS: 2403, 117, 1/2" HEAD BOLT – <b>ASSEMBLED</b>                                          |
| EQ-CH226LN  | 225 | 3.7   | 2002 - 2004 | LEFT HEAD / DRIVERS SIDE REPLACES CASTING NUMBERS: 53020983, 53020983AB WITH EGR HOLE. BLOCK-OFF KIT INCLUDED   |
| EQ-CH226RN  | 225 | 3.7   | 2002 - 2004 | RIGHT HEAD / PASSENGER SIDE REPLACES CASTING NUMBERS: 53020984, 53020984AB                                      |
| EQ-CH227LN  | 225 | 3.7   | 2005 - 2012 | LEFT HEAD / DRIVERS SIDE REPLACES CASTING NUMBERS: 53020983AD, 53020983AC WITH EGR HOLE. BLOCK-OFF KIT INCLUDED |
| EQ-CH227RN  | 225 | 3.7   | 2005 - 2012 | RIGHT HEAD / PASSENGER SIDE REPLACES CASTING NUMBER: 53020984AC                                                 |
| EQ-CH242N   | 242 | 4.0   | 1998 - 2006 | 331 CASTING                                                                                                     |
| EQ-CH242NA  | 242 | 4.0   | 1998 - 2006 | 331 CASTING – <b>ASSEMBLED</b>                                                                                  |
| EQ-CH281LN  | 287 | 4.7   | 1999 - 2008 | LEFT HEAD / DRIVERS SIDE REPLACES CASTING NUMBERS: 53020801AC, 53020803                                         |
| EQ-CH281LNA | 287 | 4.7   | 1999 - 2008 | LEFT HEAD / DRIVERS SIDE REPLACES CASTING NUMBERS: 53020801AC, 53020803 – <b>ASSEMBLED – NO CAM</b>             |

AMC / JEEP CYLINDER HEADS CONTINUED ON PAGE 6

## AMC / JEEP CYLINDER HEADS (continued)

| PART #      | CID     | LITER   | YEARS       | NOTES                                                                                                                                                                 |
|-------------|---------|---------|-------------|-----------------------------------------------------------------------------------------------------------------------------------------------------------------------|
| EQ-CH281RN  | 287     | 4.7     | 1999 - 2008 | RIGHT HEAD / PASSENGER SIDE REPLACES CASTING NUMBERS: 53020802, 53020804                                                                                              |
| EQ-CH281RNA | 287     | 4.7     | 1999 - 2008 | RIGHT HEAD / PASSENGER SIDE REPLACES CASTING NUMBERS: 53020802, 53020804 – <b>ASSEMBLED – NO CAM</b>                                                                  |
| EQ-CH318A   | 318/360 | 5.2/5.9 | 1992 - 2003 | REPLACES CASTING NUMBERS: 53005714, 53006671, 53020466, 53020468<br>172CC INTAKE RUNNER - 62CC COMBUSTION CHAMBER                                                     |
| EQ-CH318AA  | 318/360 | 5.2/5.9 | 1992 - 2003 | REPLACES CASTING NUMBERS: 53005714, 53006671, 53020466, 53020468<br>172CC INTAKE RUNNER - 62CC COMBUSTION CHAMBER – <b>ASSEMBLED</b>                                  |
| EQ-CH318B   | 318/360 | 5.2/5.9 | 1967 - 1989 | WITH LA STYLE INTAKE BOLT PATTERN REPLACES CASTING NUMBERS: 53005714, 53006671, 53020466, 53020468, 172CC INTAKE RUNNER<br>62CC COMBUSTION CHAMBER                    |
| EQ-CH318BA  | 318/360 | 5.2/5.9 | 1967 - 1989 | WITH LA STYLE INTAKE BOLT PATTERN REPLACES CASTING NUMBERS: 53005714, 53006671, 53020466, 53020468, 172CC INTAKE RUNNER<br>62CC COMBUSTION CHAMBER – <b>ASSEMBLED</b> |

## CHEVROLET CYLINDER HEADS

EQ-CH181M

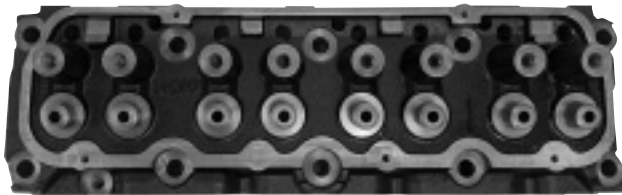

EQ-CH364BA



| PART #      | CID | LITER | YEARS       | NOTES                                                                                                                      |
|-------------|-----|-------|-------------|----------------------------------------------------------------------------------------------------------------------------|
| EQ-CH134N   | 134 | 2.2   | 1990 - 1997 | 391 / 391S - 7MM VALVE GUIDE ID                                                                                            |
| EQ-CH134NA  | 134 | 2.2   | 1990 - 1997 | 391 / 391S – <b>ASSEMBLED</b>                                                                                              |
| EQ-CH146E   | 146 | 2.4   | 2011 - 2016 | ECOTEC CASTING # 12608279                                                                                                  |
| EQ-CH146EA  | 146 | 2.4   | 2011 - 2016 | ECOTEC CASTING # 12608279 – <b>ASSEMBLED – NO CAM</b>                                                                      |
| EQ-CH181M   | 181 | 3.0   |             | REPLACES CASTING # 14096620                                                                                                |
| EQ-CH181MA  | 181 | 3.0   |             | REPLACES CASTING # 14096620 – <b>ASSEMBLED</b>                                                                             |
| EQ-CH262NC  | 262 | 4.3   | 1992 - 2014 | VORTEC DESIGN 8 BOLT INTAKE<br>REPLACES CASTING # 12557113 & 1257114                                                       |
| EQ-CH262NO  | 262 | 4.3   | 1992 - 2014 | VORTEC DESIGN 8 BOLT INTAKE<br>REPLACES CASTING # 12557113 & 12557114                                                      |
| EQ-CH262NOA | 262 | 4.3   | 1992 - 2014 | VORTEC DESIGN 8 BOLT INTAKE<br>REPLACES CASTING # 12557113 & 12557114 – <b>ASSEMBLED</b>                                   |
| EQ-CH305B   | 305 | 5.0   | 1996 - 2002 | REPLACES CASTING NUMBERS: 12552520, 12557113, 12558059,<br>INTAKE RUNNER 170CC, COMBUSTION CHAMBER 58CC                    |
| EQ-CH305BA  | 305 | 5.0   | 1996 - 2002 | REPLACES CASTING NUMBERS: 12552520, 12557113, 12558059,<br>INTAKE RUNNER 170CC, COMBUSTION CHAMBER 58CC – <b>ASSEMBLED</b> |

CHEVROLET CYLINDER HEADS CONTINUED ON PAGE 7

# THE NAME YOU TRUST FOR ENGINE PARTS

## CHEVROLET CYLINDER HEADS (continued)

| PART #     | CID | LITER | YEARS                      | NOTES                                                                                                                                                                                                                                                                                         |
|------------|-----|-------|----------------------------|-----------------------------------------------------------------------------------------------------------------------------------------------------------------------------------------------------------------------------------------------------------------------------------------------|
| EQ-CH364A  | 294 | 4.8   | 2001 - 2015                | REPLACES CASTING NUMBERS: 3317 - LQ4 / LQ9                                                                                                                                                                                                                                                    |
| EQ-CH364AA | 294 | 4.8   | 2001 - 2015                | REPLACES CASTING NUMBERS: 3317 - LQ4 / LQ9 – <b>ASSEMBLED</b>                                                                                                                                                                                                                                 |
| EQ-CH364B  | 294 | 4.8   | 2001 - 2015                | REPLACES CASTING NUMBERS: 243 / 799 - LS1 / LS6                                                                                                                                                                                                                                               |
| EQ-CH364BA | 294 | 4.8   | 2001 - 2015                | REPLACES CASTING NUMBERS: 243 / 799 - LS1 / LS6 – <b>ASSEMBLED</b>                                                                                                                                                                                                                            |
| EQ-CH364C  | 294 | 4.8   | 2001 - 2015                | REPLACES CASTING NUMBERS: 5364 / 821 / 823 - LS3 / L92                                                                                                                                                                                                                                        |
| EQ-CH364CA | 294 | 4.8   | 2001 - 2015                | REPLACES CASTING NUMBERS: 5364 / 821 / 823 - LS3 / L92 – <b>ASSEMBLED</b>                                                                                                                                                                                                                     |
| EQ-CH364A  | 323 | 5.3   | 2001 - 2015                | REPLACES CASTING NUMBERS: 3317 - LQ4 / LQ9                                                                                                                                                                                                                                                    |
| EQ-CH364AA | 323 | 5.3   | 2001 - 2015                | REPLACES CASTING NUMBERS: 3317 - LQ4 / LQ9 – <b>ASSEMBLED</b>                                                                                                                                                                                                                                 |
| EQ-CH364B  | 323 | 5.3   | 2001 - 2015                | REPLACES CASTING NUMBERS: 243 / 799 - LS1 / LS6                                                                                                                                                                                                                                               |
| EQ-CH364BA | 323 | 5.3   | 2001 - 2015                | REPLACES CASTING NUMBERS: 243 / 799 - LS1 / LS6 – <b>ASSEMBLED</b>                                                                                                                                                                                                                            |
| EQ-CH364C  | 323 | 5.3   | 2001 - 2015                | REPLACES CASTING NUMBERS: 5364 / 821 / 823 - LS3 / L92                                                                                                                                                                                                                                        |
| EQ-CH364CA | 323 | 5.3   | 2001 - 2015                | REPLACES CASTING NUMBERS: 5364 / 821 / 823 - LS3 / L92 – <b>ASSEMBLED</b>                                                                                                                                                                                                                     |
| EQ-CH350AA | 350 | 5.7   | 1955 - 1986                | UNIVERSAL / INTAKE RUNNER 178CC / COMBUSTION CHAMBER 76CC WITH HEAT RISER / 69-86 INTAKE MANIFOLD BOLT PATTERN 7-BOLT HOLE EXHAUST MOUNTING / STRAIGHT SPARK PLUG PERIMETER VALVE COVER HOLES – <b>ASSEMBLED</b>                                                                              |
| EQ-CH350G  | 350 | 5.7   | 1987 - 1995                | REPLACES CASTING NUMBERS: 14101083, 14096217, 14102191, 14102193 INTAKE RUNNER 176CC / COMBUSTION CHAMBER 64CC VORTEC STYLE WITH HEAT RISER / 87 95 INTAKE MANIFOLD BOLT PATTERN CENTER BOLT DOWN VALVE COVER HOLES / ANGLE SPARK PLUG RECOMMENDED TO BE REPLACED IN PAIRS                    |
| EQ-CH350GA | 350 | 5.7   | 1987 - 1995                | REPLACES CASTING NUMBERS: 14101083, 14096217, 14102191, 14102193 INTAKE RUNNER 176CC / COMBUSTION CHAMBER 64CC VORTEC STYLE WITH HEAT RISER / 87 95 INTAKE MANIFOLD BOLT PATTERN CENTER BOLT DOWN VALVE COVER HOLES / ANGLE SPARK PLUG RECOMMENDED TO BE REPLACED IN PAIRS – <b>ASSEMBLED</b> |
| EQ-CH350C  | 350 | 5.7   | 1996 - 2006                | REPLACES CASTING NUMBER 12558062, 10239906, INTAKE RUNNER 170CC / COMBUSTION CHAMBER 64CC STRAIGHT SPARK PLUG                                                                                                                                                                                 |
| EQ-CH350CA | 350 | 5.7   | 1996 - 2006                | REPLACES CASTING NUMBER 12558062, 10239906, INTAKE RUNNER 170CC / COMBUSTION CHAMBER 64CC STRAIGHT SPARK PLUG – <b>ASSEMBLED</b>                                                                                                                                                              |
| EQ-CH350I  | 350 | 5.7   | 1955 - 1986<br>PERFORMANCE | IMCA SANCTIONED SPORT MOD HEAD INTAKE RUNNER 178CC / COMBUSTION CHAMBER 76CC 69-86 INTAKE MANIFOLD BOLT PATTERN / 7-BOLT HOLE EXHAUST MOUNTING PERIMETER VALVE COVER HOLES / STRAIGHT SPARK PLUG / WITH HEAT RISER                                                                            |
| EQ-CH364A  | 364 | 6.0   | 2001 - 2015                | REPLACES CASTING NUMBERS: 3317 - LQ4 / LQ9                                                                                                                                                                                                                                                    |
| EQ-CH364AA | 364 | 6.0   | 2001 - 2015                | REPLACES CASTING NUMBERS: 3317 - LQ4 / LQ9 – <b>ASSEMBLED</b>                                                                                                                                                                                                                                 |
| EQ-CH364B  | 364 | 6.0   | 2001 - 2015                | REPLACES CASTING NUMBERS: 243 / 799 - LS1 / LS6                                                                                                                                                                                                                                               |
| EQ-CH364BA | 364 | 6.0   | 2001 - 2015                | REPLACES CASTING NUMBERS: 243 / 799 - LS1 / LS6 – <b>ASSEMBLED</b>                                                                                                                                                                                                                            |
| EQ-CH364C  | 364 | 6.0   | 2001 - 2015                | REPLACES CASTING NUMBERS: 5364 / 821 / 823 - LS3 / L92                                                                                                                                                                                                                                        |
| EQ-CH364CA | 364 | 6.0   | 2001 - 2015                | REPLACES CASTING NUMBERS: 5364 / 821 / 823 - LS3 / L92 – <b>ASSEMBLED</b>                                                                                                                                                                                                                     |
| EQ-CH364A  | 381 | 6.2   | 2001 - 2015                | REPLACES CASTING NUMBERS: 3317 - LQ4 / LQ9                                                                                                                                                                                                                                                    |
| EQ-CH364AA | 381 | 6.2   | 2001 - 2015                | REPLACES CASTING NUMBERS: 3317 - LQ4 / LQ9 – <b>ASSEMBLED</b>                                                                                                                                                                                                                                 |
| EQ-CH364B  | 381 | 6.2   | 2001 - 2015                | REPLACES CASTING NUMBERS: 243 / 799 - LS1 / LS6                                                                                                                                                                                                                                               |
| EQ-CH364BA | 381 | 6.2   | 2001 - 2015                | REPLACES CASTING NUMBERS: 243 / 799 - LS1 / LS6 – <b>ASSEMBLED</b>                                                                                                                                                                                                                            |
| EQ-CH364C  | 381 | 6.2   | 2001 - 2015                | REPLACES CASTING NUMBERS: 5364 / 821 / 823 - LS3 / L92                                                                                                                                                                                                                                        |
| EQ-CH364CA | 381 | 6.2   | 2001 - 2015                | REPLACES CASTING NUMBERS: 5364 / 821 / 823 - LS3 / L92 – <b>ASSEMBLED</b>                                                                                                                                                                                                                     |

CHEVROLET CYLINDER HEADS CONTINUED ON PAGE 8

## CHEVROLET CYLINDER HEADS (continued)

| PART #     | CID | LITER | YEARS                    | NOTES                                                                                                                                                                                                                                                                                                    |
|------------|-----|-------|--------------------------|----------------------------------------------------------------------------------------------------------------------------------------------------------------------------------------------------------------------------------------------------------------------------------------------------------|
| EQ-CH402A  | 402 | 6.6   | 2004 - 2006              | DURAMAX - VIN 2 LLY                                                                                                                                                                                                                                                                                      |
| EQ-CH402B  | 402 | 6.6   | 2006 - 2007              | DURAMAX - VIN D LBZ                                                                                                                                                                                                                                                                                      |
| EQ-CH454C  | 454 | 7.4   | 1996 - 2000<br>UNIVERSAL | REPLACES CASTING NUMBERS: 12560241, 10141279<br>246CC INTAKE RUNNER / 100CC COMBUSTION CHAMBER<br>VORTEC CHAMBER (.370/.3716 VALVE ID)<br>DIRECT REPLACEMENT FOR 1996 - 2000 / WHEN INSTALLING ON 1996 AND EARLIER MODELS, MUST USE BOLT DOWN ROCKER ARMS AND HEAD GASKET BY FELPRO # 1017 OR EQUIVALENT |
| EQ-CH454CA | 454 | 7.4   | 1996 - 2000              | REPLACES CASTING NUMBERS: 12560241, 10141279<br>246CC INTAKE RUNNER / 100CC COMBUSTION CHAMBER /<br>VORTEC CHAMBER (.370/.3716 VALVE ID)<br>DIRECT REPLACEMENT FOR 1996 - 2000 – ASSEMBLED                                                                                                               |

## CHRYSLER CYLINDER HEADS

EQ-CH318A

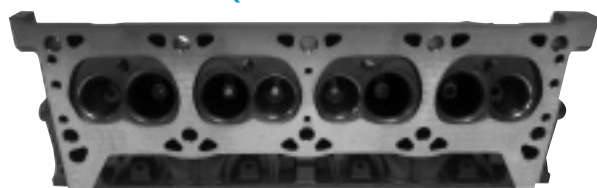

EQ-CH281LNA



EQ-CH318BA



EQ-CH281RNA

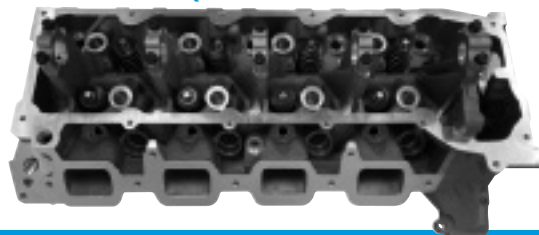

| PART #     | CID  | LITER | YEARS       | NOTES                                                                                                                 |
|------------|------|-------|-------------|-----------------------------------------------------------------------------------------------------------------------|
| EQ-CH124N  | 1997 | 2.0   | 1990 - 1992 | 4G63 - 8 VALVE WITH FUEL PUMP HOLE                                                                                    |
| EQ-CH124NA | 1997 | 2.0   | 1990 - 1992 | 4G63 - 8 VALVE WITH FUEL PUMP HOLE – ASSEMBLED – NO CAM                                                               |
| EQ-CH143A  | 2350 | 2.4   | 1993 - 1999 | 4G64 - 8 VALVE - SOHC                                                                                                 |
| EQ-CH143AA | 2350 | 2.4   | 1993 - 1999 | 4G64 - 8 VALVE - SOHC – ASSEMBLED – NO CAM                                                                            |
| EQ-CH154N  | 2555 | 2.6   | 1981 - 1990 | 4G54B - 8 VALVE - SOHC                                                                                                |
| EQ-CH154NA | 2555 | 2.6   | 1981 - 1990 | 4G54B - 8 VALVE - SOHC – ASSEMBLED – NO CAM                                                                           |
| EQ-CH226LN | 225  | 3.7   | 2002 - 2004 | LEFT HEAD / DRIVERS SIDE<br>REPLACES CASTING NUMBERS: 53020983, 53020983AB<br>WITH EGR HOLE. BLOCK-OFF KIT INCLUDED   |
| EQ-CH226RN | 225  | 3.7   | 2002 - 2004 | RIGHT HEAD / PASSENGER SIDE<br>REPLACES CASTING NUMBERS: 53020984, 53020984AB                                         |
| EQ-CH227LN | 225  | 3.7   | 2005 - 2012 | LEFT HEAD / DRIVERS SIDE<br>REPLACES CASTING NUMBERS: 53020983AD, 53020983AC<br>WITH EGR HOLE. BLOCK-OFF KIT INCLUDED |
| EQ-CH227RN | 225  | 3.7   | 2005 - 2012 | RIGHT HEAD / PASSENGER SIDE<br>REPLACES CASTING NUMBER: 53020984AC                                                    |

CHRYSLER CYLINDER HEADS CONTINUED ON PAGE 9



# THE NAME YOU TRUST FOR ENGINE PARTS

## CHRYSLER CYLINDER HEADS (continued)

| PART #      | CID | LITER | YEARS       | NOTES                                                                                                                                                                    |
|-------------|-----|-------|-------------|--------------------------------------------------------------------------------------------------------------------------------------------------------------------------|
| EQ-CH281LN  | 287 | 4.7   | 1999 - 2008 | LEFT HEAD / DRIVERS SIDE<br>REPLACES CASTING NUMBERS: 53020801AC, 53020803<br>WITH EGR HOLE. BLOCK-OFF KIT INCLUDED                                                      |
| EQ-CH281LNA | 287 | 4.7   | 1999 - 2008 | LEFT HEAD / DRIVERS SIDE<br>REPLACES CASTING NUMBERS: 53020801AC, 53020803<br>WITH EGR HOLE. BLOCK-OFF KIT INCLUDED – <b>ASSEMBLED – NO CAM</b>                          |
| EQ-CH281RN  | 287 | 4.7   | 1999 - 2008 | RIGHT HEAD / PASSENGER SIDE REPLACES CASTING NUMBERS:<br>53020802, 53020804                                                                                              |
| EQ-CH281RNA | 287 | 4.7   | 1999 - 2008 | RIGHT HEAD / PASSENGER SIDE REPLACES CASTING NUMBERS:<br>53020802, 53020804 – <b>ASSEMBLED – NO CAM</b>                                                                  |
| EQ-CH318A   | 318 | 5.2   | 1990 - 2003 | REPLACES CASTING NUMBERS: 53005714, 53006671, 53020466, 53020468<br>172CC INTAKE RUNNER / 62CC COMBUSTION CHAMBER                                                        |
| EQ-CH318AA  | 318 | 5.2   | 1990 - 2003 | REPLACES CASTING NUMBERS: 53005714, 53006671, 53020466, 53020468<br>172CC INTAKE RUNNER / 62CC COMBUSTION CHAMBER – <b>ASSEMBLED</b>                                     |
| EQ-CH318B   | 318 | 5.2   | 1967 - 1989 | WITH LA STYLE INTAKE BOLT PATTERN REPLACES CASTING NUMBERS:<br>53005714, 53006671, 53020466, 53020468, 172CC INTAKE RUNNER<br>62CC COMBUSTION CHAMBER                    |
| EQ-CH318BA  | 318 | 5.2   | 1967 - 1989 | WITH LA STYLE INTAKE BOLT PATTERN REPLACES CASTING NUMBERS:<br>53005714, 53006671, 53020466, 53020468, 172CC INTAKE RUNNER<br>62CC COMBUSTION CHAMBER – <b>ASSEMBLED</b> |
| EQ-CH318A   | 360 | 5.9   | 1990 - 2003 | REPLACES CASTING NUMBERS: 53005714, 53006671, 53020466, 53020468<br>172CC INTAKE RUNNER / 62CC COMBUSTION CHAMBER                                                        |
| EQ-CH318AA  | 360 | 5.9   | 1990 - 2003 | REPLACES CASTING NUMBERS: 53005714, 53006671, 53020466, 53020468<br>172CC INTAKE RUNNER / 62CC COMBUSTION CHAMBER – <b>ASSEMBLED</b>                                     |
| EQ-CH318B   | 360 | 5.9   | 1967 - 1989 | WITH LA STYLE INTAKE BOLT PATTERN REPLACES CASTING NUMBERS:<br>53005714, 53006671, 53020466, 53020468, 172CC INTAKE RUNNER<br>62CC COMBUSTION CHAMBER                    |
| EQ-CH318BA  | 360 | 5.9   | 1967 - 1989 | WITH LA STYLE INTAKE BOLT PATTERN REPLACES CASTING NUMBERS:<br>53005714, 53006671, 53020466, 53020468, 172CC INTAKE RUNNER<br>62CC COMBUSTION CHAMBER – <b>ASSEMBLED</b> |

## FORD CYLINDER HEADS

EQ-CH300A



EQ-CH330NDA



| PART #     | CID | LITER | YEARS       | NOTES                                                                                     |
|------------|-----|-------|-------------|-------------------------------------------------------------------------------------------|
| EQ-CH121N  | 121 | 2.0   | 2000 - 2003 | YS4E-EA - SOHC                                                                            |
| EQ-CH140A  | 140 | 2.3   | 1995 - 1997 | REPLACES CASTING NUMBERS: F57E, F87E, F5JL - DUAL SPARK PLUG                              |
| EQ-CH140AA | 140 | 2.3   | 1995 - 1997 | REPLACES CASTING NUMBERS: F57E, F87E, F5JL - DUAL SPARK PLUG<br><b>ASSEMBLED – NO CAM</b> |
| EQ-CH140A  | 153 | 2.5   | 1998 - 2001 | REPLACES CASTING NUMBERS: F57E, F87E, F5JL - DUAL SPARK PLUG                              |
| EQ-CH140AA | 153 | 2.5   | 1998 - 2001 | REPLACES CASTING NUMBERS: F57E, F87E, F5JL - DUAL SPARK PLUG<br><b>ASSEMBLED – NO CAM</b> |

FORD CYLINDER HEADS CONTINUED ON PAGE 10

## FORD CYLINDER HEADS (continued)

| PART #      | CID | LITER | YEARS       | NOTES                                                                                                                                                               |
|-------------|-----|-------|-------------|---------------------------------------------------------------------------------------------------------------------------------------------------------------------|
| EQ-CH244C   | 244 | 4.0   | 1998 - 2000 | 98TM                                                                                                                                                                |
| EQ-CH244CA  | 244 | 4.0   | 1998 - 2000 | 98TM – ASSEMBLED                                                                                                                                                    |
| EQ-CH330ND  | 281 | 4.6   | 2008 - 2010 | 3L3E, 9L3E / DRIVERS / LEFT HEAD, SOHC<br>3 VALVE / 12MM SPARK PLUG THREADS                                                                                         |
| EQ-CH330NDA | 281 | 4.6   | 2008 - 2010 | 3L3E, 9L3E / DRIVERS / LEFT HEAD, SOHC<br>3 VALVE / 12MM SPARK PLUG THREADS – ASSEMBLED – NO CAM                                                                    |
| EQ-CH330NP  | 281 | 4.6   | 2008 - 2010 | 3L3E, 9L3E / PASSENGER / RIGHT HEAD, SOHC<br>3 VALVE / 12MM SPARK PLUG THREADS                                                                                      |
| EQ-CH330NPA | 281 | 4.6   | 2008 - 2010 | 3L3E, 9L3E / PASSENGER / RIGHT HEAD, SOHC<br>3 VALVE / 12MM SPARK PLUG THREADS – ASSEMBLED – NO CAM                                                                 |
| EQ-CH300A   | 300 | 4.9   | 1987 - 1996 | E7TE, E6TE, E5TE - WITH SMOG - WITH EXHAUST SEATS                                                                                                                   |
| EQ-CH300AA  | 300 | 4.9   | 1987 - 1996 | E7TE, E6TE, E5TE - WITH SMOG - WITH EXHAUST SEATS – ASSEMBLED                                                                                                       |
| EQ-CH300B   | 300 | 4.9   | 1987 - 1996 | E7TE, E6TE, E5TE - NO SEATS - POCKET CUT SIZE:<br>EXHAUST = 1.600 +/- .005 DIAMETER / DEPTH .140 +/- .005<br>INTAKE = 1.690 +/- .005 DIAMETER / DEPTH .140 +/- .005 |
| EQ-CH330ND  | 330 | 5.4   | 2008 - 2014 | 3L3E, 9L3E / DRIVERS / LEFT HEAD, SOHC<br>3 VALVE / 12MM SPARK PLUG THREADS                                                                                         |
| EQ-CH330NDA | 330 | 5.4   | 2008 - 2014 | 3L3E, 9L3E / DRIVERS / LEFT HEAD, SOHC<br>3 VALVE / 12MM SPARK PLUG THREADS – ASSEMBLED – NO CAM                                                                    |
| EQ-CH330NP  | 330 | 5.4   | 2008 - 2014 | 3L3E, 9L3E / PASSENGER / RIGHT HEAD, SOHC<br>3 VALVE / 12MM SPARK PLUG THREADS                                                                                      |
| EQ-CH330NPA | 330 | 5.4   | 2008 - 2014 | 3L3E, 9L3E / PASSENGER / RIGHT HEAD, SOHC<br>3 VALVE / 12MM SPARK PLUG THREADS – ASSEMBLED – NO CAM                                                                 |

## ISUZU CYLINDER HEADS

EQ-CH138N

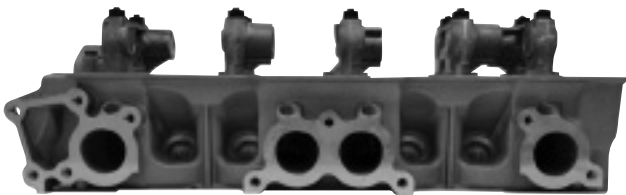

EQ-CH156NEA



| PART #       | CID    | LITER | YEARS       | NOTES                                                       |
|--------------|--------|-------|-------------|-------------------------------------------------------------|
| EQ-CH138N    | 138    | 2.3   | 1986 - 1995 | 4ZD1                                                        |
| EQ-CH156NE*  | 2559CC | 2.6   | 1988 - 1996 | 4ZE1 - ROUND SHAPED COMBUSTION CHAMBER                      |
| EQ-CH156NEA* | 2559CC | 2.6   | 1988 - 1996 | 4ZE1 - ROUND SHAPED COMBUSTION CHAMBER – ASSEMBLED – NO CAM |
| EQ-CH156NL*  | 2559CC | 2.6   | 1997 - 1997 | 4ZE1 - HEART SHAPED COMBUSTION CHAMBER                      |
| EQ-CH156NLA* | 2559CC | 2.6   | 1997 - 1997 | 4ZE1 - HEART SHAPED COMBUSTION CHAMBER – ASSEMBLED – NO CAM |

\* AVAILABLE DRILLED FOR SMOG A.I.R AS SPECIAL ORDER AT AN ADDITIONAL CHARGE

# THE NAME YOU TRUST FOR ENGINE PARTS

## MAZDA CYLINDER HEADS

EQ-CH157N

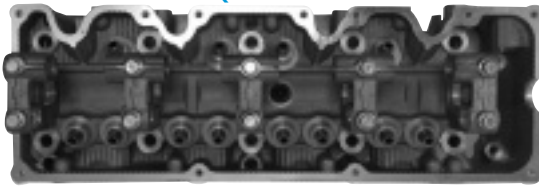

EQ-CH122AA



| PART #     | CID    | LITER | YEARS       | NOTES                                                                           |
|------------|--------|-------|-------------|---------------------------------------------------------------------------------|
| EQ-CH122A  | 1998CC | 2.0   | 1983 - 1987 | FE - SOHC                                                                       |
| EQ-CH122AA | 1998CC | 2.0   | 1983 - 1987 | FE – ASSEMBLED – NO CAM                                                         |
| EQ-CH122A  | 2184CC | 2.2   | 1987 - 1993 | F2 - SOHC                                                                       |
| EQ-CH122AA | 2184CC | 2.2   | 1987 - 1993 | F2 – ASSEMBLED – NO CAM                                                         |
| EQ-CH140A  | 140    | 2.3   | 1995 - 1997 | REPLACES CASTING NUMBERS: F57E, F87E, F5JL / DUAL SPARK PLUG                    |
| EQ-CH140AA | 140    | 2.3   | 1995 - 1997 | REPLACES CASTING NUMBERS: F57E, F87E, F5JL / DUAL SPARK PLUG ASSEMBLED – NO CAM |
| EQ-CH140A  | 153    | 2.5   | 1998 - 2001 | REPLACES CASTING NUMBERS: F57E, F87E, F5JL / DUAL SPARK PLUG                    |
| EQ-CH140AA | 153    | 2.5   | 1998 - 2001 | REPLACES CASTING NUMBERS: F57E, F87E, F5JL / DUAL SPARK PLUG ASSEMBLED – NO CAM |
| EQ-CH157N  | 2606CC | 2.6   | 1989 - 1994 | G6                                                                              |
| EQ-CH157NA | 2606CC | 2.6   | 1989 - 1994 | G6 – ASSEMBLED – NO CAM                                                         |

## MITSUBISHI CYLINDER HEADS

EQ-CH154N



EQ-CH124NA

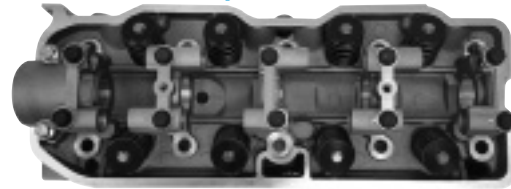

| PART #     | CID    | LITER | YEARS       | NOTES                                                   |
|------------|--------|-------|-------------|---------------------------------------------------------|
| EQ-CH124N  | 1997CC | 2.0   | 1990 - 1992 | 4G63 - 8 VALVE WITH FUEL PUMP HOLE                      |
| EQ-CH124NA | 1997CC | 2.0   | 1990 - 1992 | 4G63 - 8 VALVE WITH FUEL PUMP HOLE – ASSEMBLED – NO CAM |
| EQ-CH143A  | 2350CC | 2.4   | 1993 - 1999 | 4G64 - 8 VALVE - SOHC                                   |
| EQ-CH143AA | 2350CC | 2.4   | 1993 - 1999 | 4G64 - 8 VALVE - SOHC – ASSEMBLED – NO CAM              |
| EQ-CH154N  | 2555CC | 2.6   | 1981 - 1990 | 4G54B - 8 VALVE - SOHC                                  |
| EQ-CH154NA | 2555CC | 2.6   | 1981 - 1990 | 4G54B - 8 VALVE - SOHC – ASSEMBLED – NO CAM             |

## NISSAN CYLINDER HEADS

EQ-CH146A



EQ-CH152NA



| PART #     | CID     | LITER   | YEARS       | NOTES                                                    |
|------------|---------|---------|-------------|----------------------------------------------------------|
| EQ-CH152N  | 126/152 | 2.1/2.5 | INDUSTRIAL  | K21 / K25                                                |
| EQ-CH152NA | 126/152 | 2.1/2.5 | INDUSTRIAL  | K21 / K25 – ASSEMBLED – NO CAM                           |
| EQ-CH146A  | 2389CC  | 2.4     | 1991 – 2001 | KA24DE – DOHC REPLACES CASTING # F45 / FRONTIER & XTERRA |

## TOYOTA CYLINDER HEADS

EQ-CH164B

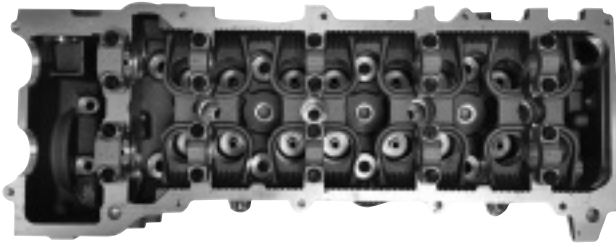

EQ-CH164AA

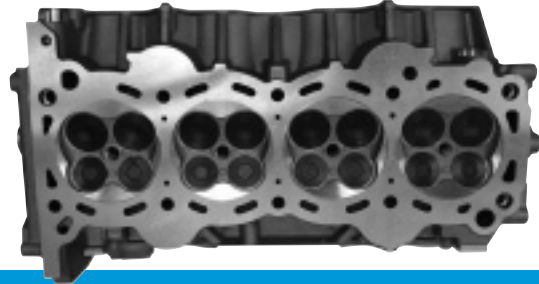

| PART #      | CID    | LITER | YEARS       | NOTES                                                                           |
|-------------|--------|-------|-------------|---------------------------------------------------------------------------------|
| EQ-CH136N   | 1998CC | 2.0   | 1984 - 1985 | 3YEC - 8 VALVE OHV                                                              |
| EQ-CH136NA  | 1998CC | 2.0   | 1984 - 1985 | 3YEC - 8 VALVE OHV – ASSEMBLED                                                  |
| EQ-CH136N   | 2237CC | 2.2   | 1986 - 1989 | 4YEC                                                                            |
| EQ-CH136NA  | 2237CC | 2.2   | 1986 - 1989 | 4YEC – ASSEMBLED                                                                |
| EQ-CH144N   | 144    | 2.4   | 1985 - 1995 | 22R, 22REC                                                                      |
| EQ-CH144NA  | 144    | 2.4   | 1985 - 1995 | 22R, 22REC – ASSEMBLED – NO CAM                                                 |
| EQ-CH164B   | 2438CC | 2.4   | 1997 - 2000 | 2RZFE – DOHC 16 VALVES – 8 PORT– INCLUDES DISTRIBUTOR AND CAM SENSOR BLOCK-OFFS |
| EQ-CH164B   | 2694CC | 2.7   | 1994 - 2000 | 3RZFE - DOHC 16 VALVES – 8 PORT– INCLUDES DISTRIBUTOR AND CAM SENSOR BLOCK-OFFS |
| EQ-CH164A   | 2694CC | 2.7   | 2005 - 2013 | 2TRFE - DOHC                                                                    |
| EQ-CH164AA  | 2694CC | 2.7   | 2005 - 2013 | 2TRFE - DOHC – ASSEMBLED – NO CAM                                               |
| EQ-CH181ND  | 180    | 3.0   | 1988 - 1995 | 3VZE SOHC DRIVER / LEFT                                                         |
| EQ-CH181NDA | 180    | 3.0   | 1988 - 1995 | 3VZE SOHC DRIVER / LEFT – ASSEMBLED – NO CAM                                    |
| EQ-CH181NP  | 180    | 3.0   | 1988 - 1995 | 3VZE SOHC PASSENGER / RIGHT                                                     |
| EQ-CH181NPA | 180    | 3.0   | 1988 - 1995 | 3VZE SOHC PASSENGER / RIGHT – ASSEMBLED – NO CAM                                |

## INDUSTRIAL / FORKLIFT CYLINDER HEADS

EQ-CH136N



EQ-CH143AA

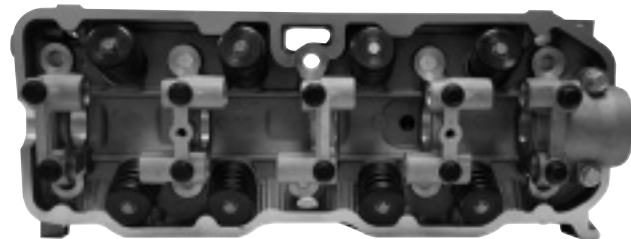

| MFG       | PART #      | CID | LITER | YEARS       | NOTES                                                                             |
|-----------|-------------|-----|-------|-------------|-----------------------------------------------------------------------------------|
| CHEVROLET | EQ-CH181M   | 181 | 3.0   |             | REPLACES CASTING # 14096620                                                       |
| CHEVROLET | EQ-CH181MA  | 181 | 3.0   |             | REPLACES CASTING # 14096620 – ASSEMBLED                                           |
| CHEVROLET | EQ-CH262NC  | 262 | 4.3   | 1992 - 2014 | VORTEC DESIGN 8 BOLT INTAKE<br>REPLACES CASTING # 12557113 & 1257114              |
| CHEVROLET | EQ-CH262NO  | 262 | 4.3   | 1992 - 2014 | VORTEC DESIGN 8 BOLT INTAKE<br>REPLACES CASTING # 12557113 & 12557114             |
| CHEVROLET | EQ-CH262NOA | 262 | 4.3   | 1992 - 2014 | VORTEC DESIGN 8 BOLT INTAKE<br>REPLACES CASTING # 12557113 & 12557114 – ASSEMBLED |

INDUSTRIAL / FORKLIFT CYLINDER HEADS CONTINUED ON PAGE 13

# THE NAME YOU TRUST FOR ENGINE PARTS

## INDUSTRIAL / FORKLIFT CYLINDER HEADS (continued)

| MFG       | PART #     | CID     | LITER   | YEARS       | NOTES                                                                                     |
|-----------|------------|---------|---------|-------------|-------------------------------------------------------------------------------------------|
| FORD      | EQ-CH140A  | 140     | 2.3     | 1995 - 1997 | REPLACES CASTING NUMBERS: F57E, F87E, F5JL - DUAL SPARK PLUG                              |
| FORD      | EQ-CH140AA | 140     | 2.3     | 1995 - 1997 | REPLACES CASTING NUMBERS: F57E, F87E, F5JL - DUAL SPARK PLUG<br><b>ASSEMBLED – NO CAM</b> |
| FORD      | EQ-CH140A  | 153     | 2.5     | 1998 - 2001 | REPLACES CASTING NUMBERS: F57E, F87E, F5JL - DUAL SPARK PLUG                              |
| FORD      | EQ-CH140AA | 153     | 2.5     | 1998 - 2001 | REPLACES CASTING NUMBERS: F57E, F87E, F5JL - DUAL SPARK PLUG<br><b>ASSEMBLED – NO CAM</b> |
| FORD      | EQ-CH300A  | 300     | 4.9     | 1987 - 1996 | E77E, E67E, E57E - WITH SMOG - WITH EXHAUST SEATS                                         |
| FORD      | EQ-CH300AA | 300     | 4.9     | 1987 - 1996 | E77E, E67E, E57E - WITH SMOG - WITH EXHAUST SEATS – <b>ASSEMBLED</b>                      |
| FORD      | EQ-CH300B  | 300     | 4.9     | 1987 - 1996 | E77E, E67E, E57E - NO SEATS                                                               |
| MAZDA     | EQ-CH122A  | 1998CC  | 2.0     | 1983 - 1987 | FE - SOHC                                                                                 |
| MAZDA     | EQ-CH122AA | 1998CC  | 2.0     | 1983 - 1987 | FE – <b>ASSEMBLED – NO CAM</b>                                                            |
| MAZDA     | EQ-CH122A  | 2184CC  | 2.2     | 1987 - 1993 | F2 - SOHC                                                                                 |
| MAZDA     | EQ-CH122AA | 2184CC  | 2.2     | 1987 - 1993 | F2 – <b>ASSEMBLED – NO CAM</b>                                                            |
| MINIBISHI | EQ-CH124N  | 1997CC  | 2.0     | 1990 - 1992 | 4G63 - 8 VALVE WITH FUEL PUMP HOLE                                                        |
| MINIBISHI | EQ-CH124NA | 1997CC  | 2.0     | 1990 - 1992 | 4G63 - 8 VALVE WITH FUEL PUMP HOLE – <b>ASSEMBLED – NO CAM</b>                            |
| MINIBISHI | EQ-CH143A  | 2350CC  | 2.4     | 1993 - 1999 | 4G64 - 8 VALVE - SOHC                                                                     |
| MINIBISHI | EQ-CH143AA | 2350CC  | 2.4     | 1993 - 1999 | 4G64 - 8 VALVE - SOHC – <b>ASSEMBLED – NO CAM</b>                                         |
| MINIBISHI | EQ-CH154N  | 2555CC  | 2.6     | 1981 - 1990 | 4G54B 8 VALVE - SOHC                                                                      |
| MINIBISHI | EQ-CH154NA | 2555CC  | 2.6     | 1981 - 1990 | 4G54B 8 VALVE - SOHC – <b>ASSEMBLED – NO CAM</b>                                          |
| NISSAN    | EQ-CH152N  | 126/152 | 2.1/2.5 | INDUSTRIAL  | K21 / K25                                                                                 |
| NISSAN    | EQ-CH152NA | 126/152 | 2.1/2.5 | INDUSTRIAL  | K21 / K25 – <b>ASSEMBLED – NO CAM</b>                                                     |
| TOYOTA    | EQ-CH136N  | 1998CC  | 2.0     | 1984 - 1985 | 3YEC - 8 VALVE OHV                                                                        |
| TOYOTA    | EQ-CH136NA | 1998CC  | 2.0     | 1984 - 1985 | 3YEC - 8 VALVE OHV – <b>ASSEMBLED</b>                                                     |
| TOYOTA    | EQ-CH136N  | 2237CC  | 2.2     | 1986 - 1989 | 4YEC                                                                                      |
| TOYOTA    | EQ-CH136NA | 2237CC  | 2.2     | 1986 - 1989 | 4YEC – <b>ASSEMBLED</b>                                                                   |

## 23 DEGREE CAST IRON PERFORMANCE HEAD



- AS CAST combustion chambers and ports
- DuraBond Exhaust Seats
- 3-angle valve job
- Thick deck faces for angle milling
- Phosphor bronze intake and exhaust guide
- Machined for guide plates and screw in studs
- Raised intake runner ports for increased performance

| PART #     | INTAKE RUNNER VOLUME | COMBUSTION CHAMBER VOLUME | SPARK PLUG HOLE | INTAKE VALVE | EXHAUST VALVE | GUIDE I.D. | GUIDE O.D. | INTAKE PORT WIDTH | INTAKE PORT HEIGHT | EXHAUST PORT WIDTH | EXHAUST PORT HEIGHT |
|------------|----------------------|---------------------------|-----------------|--------------|---------------|------------|------------|-------------------|--------------------|--------------------|---------------------|
| EQ-CC200BA | 200CC                | 64CC                      | ANGLE           | 2.02"        | 1.60"         | .343"      | .530/.531" | 1.23"             | 2.12"              | 1.35"              | 1.35"               |

## SCREW IN STUDS



EQ-SIS350

Small Block Chevrolet & 3.0L 181 4-Cylinder Marine Industrial

Each Cylinder Head Requires The Use Of A Screw-In Rocker Arm Stud

PART# EQ-SIS350 (8 pcs. per set, enough for 1 cylinder head)

- STUDS MEASURE 7/16-14 X 3/8-24 X 2.375" OVERALL
- HEAT TREATED TO RC 33-39 AND ARE OXIDE

## HEAD GASKET SETS

| PART #     | MFG    | DISPLACEMENT | ENGINE             | YEARS       |
|------------|--------|--------------|--------------------|-------------|
| EQ-GS4ZE1  | ISUZU  | 2559CC       | 4ZE1 - 2.6L        | 1988 - 1997 |
| EQ-GSFE-F2 | MAZDA  | 1998         | FE - 2.0L          | 1983 - 1987 |
| EQ-GSFE-F2 | MAZDA  | 2184         | F2 - 2.2L          | 1987 - 1993 |
| EQ-GSG6    | MAZDA  | 2606CC       | G6 - 2.6L          | 1989 - 1994 |
| EQ-GSG64   | MAZDA  | 2350CC       | 4G64 - 2.4L        | 1993 - 1999 |
| EQ-GSK21N  | NISSAN | 126          | K21 / K25 - 2.1L   | INDUSTRIAL  |
| EQ-GS4Y    | TOYOTA | 1998         | 3Y/3YE 2.0L        | 1984 - 1985 |
| EQ-GS4Y    | TOYOTA | 2237CC       | 4Y / 4YEC 2.2L     | 1986 - 1989 |
| EQ-GS22R   | TOYOTA | 144          | 22R , 22REC - 2.4L | 1985 - 1995 |

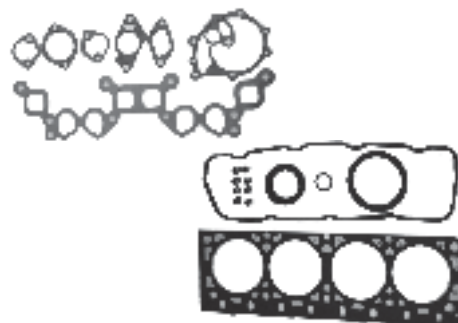

## ROCKER ARM GUIDE PLATE CONVERSION KIT

### 3/8" Rocker Arm Guide Plate Conversion Kit for Dodge/Ford

Features premium heat treated studs and exclusive guide plates along with an adjustable configuration without machining. This conversion kit provides an easy way to convert net lash cylinder heads.

- Guide plate pushrod size 5/16"
- Guide plates included Yes
- Rocker arm nuts included No
- Rocker arm studs included Yes
- Rocker arms included No
- Rocker stud thread diameter 3/8" - 24"

#### EQ-GPK4

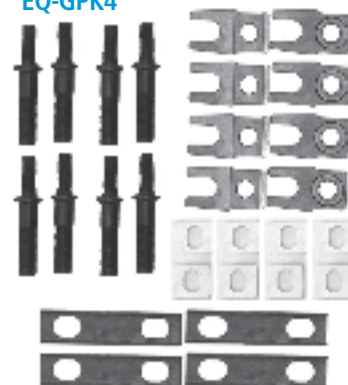

| PART #   | QTY        | APPLICATIONS                  |
|----------|------------|-------------------------------|
| EQ-GPK4  | SET OF 4   | FORD 140, 153, 302, 351W, 300 |
| EQ-GPK6  | SET OF 6   | & DODGE 318, 360              |
| EQ-GPKIT | INDIVIDUAL |                               |

## ROCKER ARM GUIDE & PLATES

### Steel Guide That Goes Below The Rocker Arm Fulcrum

Replaces FORD # E5TZ6A588A

| PART #     | QTY      | APPLICATION                                                                                                                                                                                                                                                                                 |
|------------|----------|---------------------------------------------------------------------------------------------------------------------------------------------------------------------------------------------------------------------------------------------------------------------------------------------|
| EQ-RGFO    | 24       | 2.5 HSC / 300 L6 / 302 / 351C / 351M / 351W / 400 / 460                                                                                                                                                                                                                                     |
| EQ-RGFOBLK | 240      |                                                                                                                                                                                                                                                                                             |
| EQ-RB302N  | 10       | ROCKER BOLT FOR EQ-RGFO<br>2.5 HSC / 300 L6 / 302 / 351C / 351M / 351W / 400 / 460                                                                                                                                                                                                          |
| EQ-GP181M* | SET OF 4 | ORDER EQ-SIS350 SEPARATELY.<br>KEEPS ROCKER ARM FROM WALKING OFF THE VALVE TIP.<br>*USE WITH THE FOLLOWING CYLINDER HEAD PART NUMBERS:<br>EQ-CH181M / EQ-CH181MA      EQ-CH350I<br>EQ-CH305B / EQ-CH305BA      EQ-CH350G / EQ-CH350GA<br>EQ-CH350C / EQ-CH350CA      EQ-CH350A / EQ-CH350AA |



## TRUNNION STYLE ROCKER ARM SET

| PART #    | DESCRIPTION                                                                                               |
|-----------|-----------------------------------------------------------------------------------------------------------|
| EQ-RA294P | UPGRADED TRUNNION STYLE ROCKER ARM SET FOR ALL LS3 AND LATER ENGINES, 1.7 ROCKER RATIO, 16 PIECES PER SET |



# THE NAME YOU TRUST FOR ENGINE PARTS

## ROCKER SHAFT ASSEMBLY

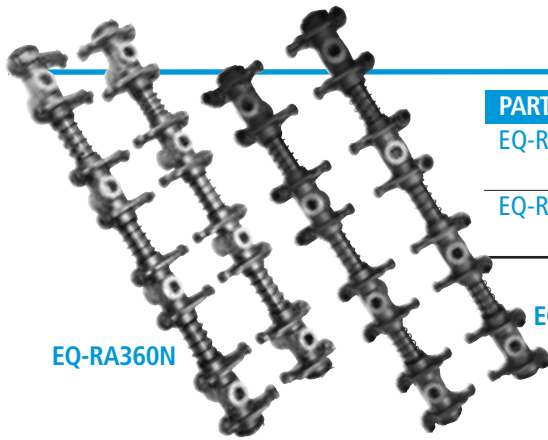

EQ-RA360N

EQ-RA360NA

| PART #     | MFG  | VEHICLE     | ENGINE                                      | NOTES                     |
|------------|------|-------------|---------------------------------------------|---------------------------|
| EQ-RA360N  | FORD | CAR & TRUCK | 330, 352, 360, 361, 390, 391, 410, 427, 428 | ALL NEW<br>NON-ADJUSTABLE |
| EQ-RA360NA | FORD | CAR & TRUCK | 330, 352, 360, 361, 390, 391, 410, 427, 429 | ALL NEW<br>ADJUSTABLE     |

## ROLLER LIFTER GUIDES & RETAINERS

EQ-RLR294N



EQ-RLG350



EQ-RLG454



EQ-RLR350N



| PART #        | ENG MFG   | CID   | LITERS             | YEARS       | NOTES                                                                                                |
|---------------|-----------|-------|--------------------|-------------|------------------------------------------------------------------------------------------------------|
| EQ-RLR294N    | CHEVROLET | LS V8 | 4.8, 5.3, 6.0, 6.2 | 2001 - 2020 | COMPLETE SET OF 4 WITH BOLTS                                                                         |
| EQ-RLB294N    | CHEVROLET | LS V8 | 4.8, 5.3, 6.0, 6.2 | 2001 - 2020 | LIFTER GUIDE BOLTS                                                                                   |
| EQ-RLB294NBLK | CHEVROLET | LS V8 | 4.8, 5.3, 6.0, 6.2 | 2001 - 2020 | LIFTER GUIDE BOLTS, PACK OF 480                                                                      |
| EQ-RLG350     | CHEVROLET | 350   | 5.7                | 1986 - UP   | ALSO KNOWN AS CLIPS                                                                                  |
| EQ-RLG454     | CHEVROLET | 454   | 7.4                | 1986 - UP   | ALSO KNOWN AS CLIPS                                                                                  |
| EQ-RLR350N    | CHEVROLET | 305   | 5.0                | 1986 - 1997 | ALSO KNOWN AS SPIDER                                                                                 |
| EQ-RLR350N    | CHEVROLET | 350   | 5.7                | 1986 - 1997 | ALSO KNOWN AS SPIDER                                                                                 |
| EQ-RLR350KIT  | CHEVROLET | 305   | 5.0                | 1986 - 1997 | RETAINER, 3 MOUNTING BOLTS, 8 CLIPS                                                                  |
| EQ-RLR350KIT  | CHEVROLET | 350   | 5.7                | 1986 - 1997 | RETAINER, 3 MOUNTING BOLTS, 8 CLIPS                                                                  |
| EQ-RLRDLXA    | CHEVROLET | 305   | 5.0                | 1986 - 1990 | RETAINER, 3 MOUNTING BOLTS, 8 CLIPS,<br>CAM THRUST PLATE (4.23" T2T)<br>CAM PLATE MOUNTING BOLTS (2) |
| EQ-RLRDLXA    | CHEVROLET | 350   | 5.7                | 1986 - 1990 | RETAINER, 3 MOUNTING BOLTS, 8 CLIPS,<br>CAM THRUST PLATE (4.23" T2T)<br>CAM PLATE MOUNTING BOLTS (2) |
| EQ-RLRDLXB    | CHEVROLET | 305   | 5.0                | 1991 - 2002 | RETAINER, 3 MOUNTING BOLTS, 8 CLIPS,<br>CAM THRUST PLATE (3.90" T2T)<br>CAM PLATE MOUNTING BOLTS (2) |
| EQ-RLRDLXB    | CHEVROLET | 350   | 5.7                | 1991 - 2002 | RETAINER, 3 MOUNTING BOLTS, 8 CLIPS,<br>CAM THRUST PLATE (3.90" T2T)<br>CAM PLATE MOUNTING BOLTS (2) |

## DOWEL PINS

EQ-HD454



EQ-BDV8F



| PART #   | DESCRIPTION                              |
|----------|------------------------------------------|
| EQ-HD454 | CHEVROLET BIG BLOCK CYLINDER HEAD DOWEL  |
| EQ-BDV8F | FORD V8 BLOCK TO TRANS DOWEL HEAD 6397AB |

## OIL GALLEY PLUGS

### Chevrolet LS

| PART #        | QTY | ITEM/NOTES                                                         |
|---------------|-----|--------------------------------------------------------------------|
| EQ-OGP294N    | 5   | CHEVROLET LS OIL GALLEY PLUG                                       |
| EQ-OGP294NBLK | 50  | OIL GALLEY PLUG LS1 LS3 LS4 LS7 L99 LSA<br>REPLACES OEM # 12573460 |



EQ-OGP294N

## SYSTEM COOLANT PLUGS

### Chevrolet LS

All cooling systems need high-quality components to function well and provide maximum cooling ability. EngineQuest coolant system air bleed plugs are made of steel and are designed to bleed air from cooling systems to avoid any major issues. It's highly recommended that two air bleed plugs be used per engine to complete the bleeding process, for the very best results.

| PART #       | QTY | NOTES                                            |
|--------------|-----|--------------------------------------------------|
| EQ-BP085N    | 5   | CHEVROLET LS COOLANT SYSTEM AIR BLEED PLUG       |
| EQ-BP085NBLK | 50  | 1997-2003 GM LS SERIES<br>REPLACES GM # 12602540 |



EQ-BP085N

## VALVE COVER BOLT SET

| PART #        | DESCRIPTION                                     |
|---------------|-------------------------------------------------|
| EQ-VCB294N    | FITS ALL LS3 AND LATER ENGINES, SET OF 8        |
| EQ-VCB294NBLK | FITS ALL LS3 AND LATER ENGINES, BULK PACK OF 80 |

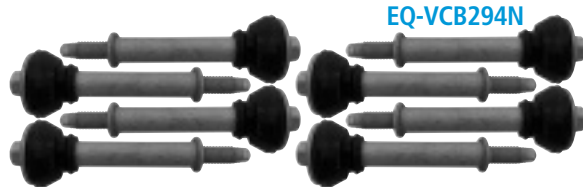

EQ-VCB294N

## WATER OUTLET TUBE

| PART #   | DESCRIPTION                                                |
|----------|------------------------------------------------------------|
| EQ-WPH20 | H20 NISSAN FORKLIFT WATER PIPE FROM RADIATOR TO THERMOSTAT |

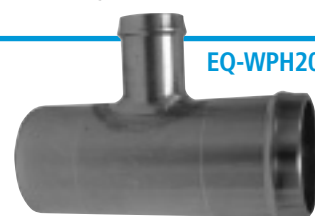

EQ-WPH20

## CAM ECCENTRICS



| PART #    | DESCRIPTION                                                      |
|-----------|------------------------------------------------------------------|
| EQ-CE120I | FORD V8 255, 302, 351W, 400, 460 INNER CAM ECCENTRIC (UP TO 85)  |
| EQ-CE1200 | FORD V8 255, 302, 351W, 400, 460 OUTER CAM ECCENTRIC (UP TO 85)  |
| EQ-CE121N | FORD V8 255, 302, 351W, 400 CAM ECCENTRIC (85 & UP) WASHER       |
| EQ-CE124N | AMC V8 (INCL. DIST. GEAR, SPACER, WASHER & BOLT)                 |
| EQ-CE129N | TOYOTA 20R, 21R, 22R, 22REC (INCLUDES DRIVE GEAR, BOLT & WASHER) |
| EQ-CE390N | FORD 360/390 2 PIECE CAM ECCENTRIC                               |



# THE NAME YOU TRUST FOR ENGINE PARTS

## AMC CAMSHAFT BOLT

EQ-CB243N



| PART #    | MFG      | APPLICATION           | DESCRIPTION       | OEM #    |
|-----------|----------|-----------------------|-------------------|----------|
| EQ-CB243N | AMC/JEEP | LATE MODEL 4.0 & 4.2L | NEW CAM GEAR BOLT | 83502890 |

## FUEL PUMP BLOCK OFF PLATES

EQ-BOP076



EQ-BOP087



| PART #    | QTY       | ITEM/NOTES                                                                                                                                                                                              |
|-----------|-----------|---------------------------------------------------------------------------------------------------------------------------------------------------------------------------------------------------------|
| EQ-BOP076 | PACK OF 5 | UNIVERSAL STYLE PLATE WITH GASKET<br>FITS: FORDS - ALL EXCEPT 2.8L, 351C, 351M, 400<br>DODGE - ALL DOMESTIC<br>PONTIAC - ALL V8<br>CHEVROLET - BIG BLOCK, 250, 292<br>AMC - 6 CYL, V8<br>BUICK - V6, V8 |
| EQ-BOP087 | PACK OF 5 | SMALL BLOCK CHEVROLET WITH GASKET<br>GASKET FITS CHEVROLET - ALL SMALL BLOCK (4 HOLE)                                                                                                                   |

## CRANKSHAFTS

EQ-CSK21N



K21 Nissan Forklift Crankshaft

| PART #    | DESCRIPTION                                                                                                                                                                                                                                                                       |
|-----------|-----------------------------------------------------------------------------------------------------------------------------------------------------------------------------------------------------------------------------------------------------------------------------------|
| EQ-CSK21N | K21 NISSAN FORKLIFT CRANKSHAFT<br>REPLACES PART NUMBER: 91H20-00990 N-12201-FU400<br>INCLUDES: 1PC ONLY - NO BEARINGS<br>STANDARD SIZE ROD AND MAIN JOURNALS<br>ROD JOURNAL DIAMETER 1.7701-1.7706" (44.961-44.974 MM)<br>MAIN JOURNAL DIAMETER 2.4780-2.4785" (62.942-62.955 MM) |

## HARMONIC BALANCERS & REPLACEMENT SLEEVES

EQ-BA289N



EQ-BA390N



EQ-BA460A



EQ-SLF460



EQ-SLFE



| PART #    | MFG  | LITERS        | CID                                | YEARS       | NOTES                       |
|-----------|------|---------------|------------------------------------|-------------|-----------------------------|
| EQ-BA289N | FORD | 4.7           | 289                                | 1965 - 1969 | 3 BOLT                      |
| EQ-BA390N | FORD | 5.9, 6.4, 7.0 | 330MD, 352, 360, 390, 410, 427,428 | 1964 - 1978 | ALL FE ENGINES, EXCEPT HD   |
| EQ-BA460A | FORD | 7.0, 7.5      | 429, 460                           | 1968 - 1997 |                             |
| EQ-SLF460 | FORD | 7.0, 7.5      | 429, 460                           | 1968 - 1978 | INTERNALLY BALANCED ENGINES |
| EQ-SLFE   | FORD | 5.9, 6.4, 7.0 | 330MD, 352, 360, 390, 410, 427,428 | 1964 - 1978 | ALL FE ENGINES, EXCEPT HD   |

## OIL FILTER ADAPTERS

EQ-OFA142



EQ-OFA173



EQ-OFA183



EQ-OFA244



EQ-OFA258



EQ-OFA262



EQ-OFA294A



EQ-OFA294B



EQ-OFA302



EQ-OFA305



EQ-OFA345

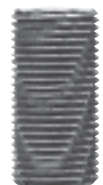

EQ-OFA346



EQ-OFA454



EQ-OFA460



| PART #        | MFG      | APPLICATION                 | YEARS       | OEM#      | QTY  |
|---------------|----------|-----------------------------|-------------|-----------|------|
| EQ-OFA258     | AMC/JEEP | 4.0L 244 CID                | 1981 - 1986 | J3173226  | 5    |
| EQ-OFA258     | AMC/JEEP | 4.2L 258 CID                | 1981 - 1986 | J3173226  | 5    |
| EQ-OFA258     | AMC/JEEP | 5.0L 304 CID                | 1970 - 1981 |           | 5    |
| EQ-OFA258     | AMC/JEEP | 5.9L 360 CID                | 1970 - 1991 |           | 5    |
| EQ-OFA258     | AMC/JEEP | 6.6L 401 CID                | 1970 - 1978 |           | 5    |
| EQ-OFA173     | CHEVY    | 1.8L                        | 1982 - UP   | 466383    | 5    |
| EQ-OFA173     | CHEVY    | 2.0L                        | 1982 - UP   | 466383    | 5    |
| EQ-OFA173     | CHEVY    | 2.8L 173 CID                | 1982 - UP   | 466383    | 5    |
| EQ-OFA262     | CHEVY    | 4.3L 262 CID                | 1986 - UP   | 14081300  | 10   |
| EQ-OFA305     | CHEVY    | SMALL BLOCK                 | 1967 - UP   | 3952301   | EACH |
| EQ-OFA294A    | CHEVY    | 4.8, 5.3, 6.0, 6.2L         | 2006 - 2019 | 12600225  | 5    |
| EQ-OFA294ABLK | CHEVY    | 4.8, 5.3, 6.0, 6.2L         | 2006 - 2019 | 12600225  | 50   |
| EQ-OFA294B    | CHEVY    | 4.8, 5.3, 6.0, 6.2L         | 1998 - 2009 | 12552357  | 5    |
| EQ-OFA294BBLK | CHEVY    | 4.8, 5.3, 6.0, 6.2L         | 1998 - 2009 | 12552357  | 50   |
| EQ-OFA454     | CHEVY    | 7.4, 8.1L BIG BLOCK GEN 5/6 | 1991 - 2000 | 3853870   | 5    |
| EQ-OFA454BLK  | CHEVY    | 7.4, 8.1L BIG BLOCK GEN 5/6 | 1991 - 2000 | 3853870   | 50   |
| EQ-OFA345     | CHRY     | 5.7L HEMI                   | 2003 - 2008 | 4104511A  | 10   |
| EQ-OFA345BLK  | CHRY     | 5.7L HEMI                   | 2003 - 2008 | 4104511A  | 50   |
| EQ-OFA346     | CHRY     | 5.7L HEMI                   | 2009 - UP   | 4892338AB | 5    |
| EQ-OFA346BLK  | CHRY     | 5.7L HEMI                   | 2010 - UP   | 4892338AB | 50   |
| EQ-OFA098     | FORD     | 1.6L 98 CID                 | 1981 - 1985 | F4FZ6890A | 5    |
| EQ-OFA183     | FORD     | 3.0L 183 CID                | 1986 - 1991 | E6DZ6890A | 5    |
| EQ-OFA244     | FORD     | 4.0L 244 CID                | 1992 - 1998 | FOTZ6890A | 5    |
| EQ-OFA302     | FORD     | 3.8L 232 CID                | 1970 - 1996 | D7AZ6890A | 10   |
| EQ-OFA302     | FORD     | 4.9L 300 CID                | 1970 - 1996 | D7AZ6890A | 10   |
| EQ-OFA302     | FORD     | 5.0L 302 CID                | 1970 - 1996 | D7AZ6890A | 10   |
| EQ-OFA302     | FORD     | 5.8L 351W CID               | 1970 - 1996 | D7AZ6890A | 10   |
| EQ-OFA302     | FORD     | 5.8L 351M CID               | 1970 - 1981 | D7AZ6890A | 10   |
| EQ-OFA302     | FORD     | 6.6L 400 CID                | 1970 - 1981 | D7AZ6890A | 10   |
| EQ-OFA302BLK  | FORD     | 3.8, 4.9, 5.0, 5.8, 6.6L    | 1970 - 1996 | D7AZ6890A | 100  |
| EQ-OFA460     | FORD     | 7.5L 460 CID                | 1969 - 1996 | C9AE6890A | 5    |
| EQ-OFA142     | OLDS     | 2.3L QUAD 4                 | 1987 - 2002 | 22538711  | 5    |

# THE NAME YOU TRUST FOR ENGINE PARTS

## OIL PANS

| PART #    | MFG   | APPLICATION        | ENGINE    | LITERS | YEARS       | NOTES                                           |
|-----------|-------|--------------------|-----------|--------|-------------|-------------------------------------------------|
| EQ-OP134N | CHEVY | S10 / SONOMA       | 134       | 2.2    | 1997 - 2003 | WITHOUT SENSOR                                  |
| EQ-OP262M | CHEVY | MARINE             | 262       | 4.3    | 1986 - 1993 | 1 PIECE REAR SEAL APPLICATION                   |
| EQ-OP350E | CHEVY | CAR, PICKUP & VAN  | 305       | 5.0    | 1970 - 1979 | LEFT DIP, 2 PIECE SEAL                          |
| EQ-OP305L | CHEVY | CAR, PICKUP & VAN  | 305       | 5.0    | 1980 - 1985 | RIGHT DIP, 2 PIECE SEAL                         |
| EQ-OP350L | CHEVY | CAR, PICKUP & VAN  | 305       | 5.0    | 1986 - 2000 | 5 QUART PAN, 1 PIECE SEAL                       |
| EQ-OP350M | CHEVY | MARINE             | 305       | 5.0    | 1986 - 1996 | 5 QUART W/OUT BAFFLE 1/2" DRAIN PLUG, 1 PC SEAL |
| EQ-OP350N | CHEVY | MARINE             | 305       | 5.0    | 1989 - 1996 | 5 QUART W/OUT BAFFLE 12MM DRAIN PLUG, 1 PC SEAL |
| EQ-OP350E | CHEVY | CAR, PICKUP & VAN  | 350       | 5.7    | 1970 - 1979 | LEFT DIP, 2 PIECE SEAL                          |
| EQ-OP305L | CHEVY | CAR, PICKUP & VAN  | 350       | 5.7    | 1980 - 1985 | RIGHT DIP, 2 PIECE SEAL                         |
| EQ-OP350L | CHEVY | CAR, PICKUP & VAN  | 350       | 5.7    | 1986 - 2000 | 5 QUART PAN, 1 PIECE SEAL                       |
| EQ-OP350M | CHEVY | MARINE             | 350       | 5.7    | 1986 - 2000 | 5 QUART W/OUT BAFFLE 1/2" DRAIN PLUG, 1 PC SEAL |
| EQ-OP350N | CHEVY | MARINE             | 350       | 5.7    | 1986 - 1996 | 5 QUART W/OUT BAFFLE 12MM DRAIN PLUG, 1 PC SEAL |
| EQ-OP454  | CHEVY | CAR & TRUCK        | 396       | 6.5    | 1965 - 1990 | 2 PIECE REAR SEAL APPLICATION                   |
| EQ-OP350E | CHEVY | CAR, PICKUP & VAN  | 400       | 6.6    | 1970 - 1979 | LEFT DIP, 2 PIECE SEAL                          |
| EQ-OP454  | CHEVY | CAR & TRUCK        | 402       | 6.6    | 1970 - 1979 | 2 PIECE REAR SEAL APPLICATION                   |
| EQ-OP454  | CHEVY | CAR & TRUCK        | 454       | 7.4    | 1965 - 1990 | 2 PIECE REAR SEAL APPLICATION                   |
| EQ-OP302A | FORD  | BRONCO, P/UP / VAN | 302       | 5.0    | 1980 - 1996 |                                                 |
| EQ-OP400N | FORD  | BRONCO, P/UP / VAN | 351C/351M | 5.8    | 1974 - 1980 | FRONT SUMP                                      |
| EQ-OP400N | FORD  | BRONCO, P/UP / VAN | 400       | 6.6    | 1974 - 1980 | FRONT SUMP                                      |

## OIL PAN RAIL SET

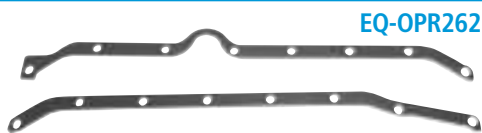

| PART #    | MFG   | CID | LITERS | YEARS       | NOTES                                                                 |
|-----------|-------|-----|--------|-------------|-----------------------------------------------------------------------|
| EQ-OPR262 | CHEVY | 262 | 4.3    | 1986 - 1993 | FOR USE ON 1 PIECE REAR SEAL ENGINE AND WITH OIL PAN PART # EQ-OP262M |
| EQ-OPR350 | CHEVY | 305 | 5.0    | 1985 - 2002 | FOR USE ON 1 PIECE REAR SEAL ENGINE                                   |
| EQ-OPR350 | CHEVY | 350 | 5.7    | 1985 - 2002 | FOR USE ON 1 PIECE REAR SEAL ENGINE                                   |

## WINDAGE TRAY/OIL BAFFLE

EQ-WTC350N



EQ-WTC403N

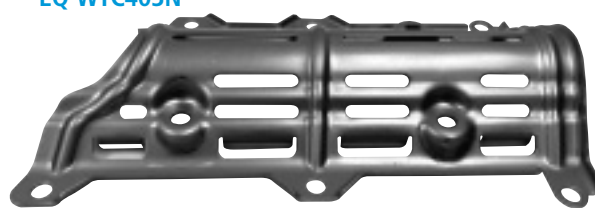

EQ-SBM350



| PART #     | MFG       | CID | LITERS | YEARS       | NOTES                                          |
|------------|-----------|-----|--------|-------------|------------------------------------------------|
| EQ-WTC350N | CHEVROLET | 305 | 5.0    | 1979 - 2000 | WINDAGE TRAY / OIL BAFFLE                      |
| EQ-WTC350N | CHEVROLET | 350 | 5.7    | 1979 - 2000 | WINDAGE TRAY / OIL BAFFLE                      |
| EQ-SBM350  | CHEVROLET | 262 | 4.3    | 1986 - 1993 | STUDDED MAIN BOLT / WINDAGE TRAY MOUNTING BOLT |
| EQ-SBM350  | CHEVROLET | 305 | 5.0    | 1979 - 2000 | STUDDED MAIN BOLT / WINDAGE TRAY MOUNTING BOLT |
| EQ-SBM350  | CHEVROLET | 350 | 5.7    | 1979 - 2000 | STUDDED MAIN BOLT / WINDAGE TRAY MOUNTING BOLT |
| EQ-WTC403N | CHEVROLET | 403 | 6.6    | 2011 - 2016 | DURAMAX DIESEL                                 |

## NEW OEM TYPE TINWARE

EQ-VC134N

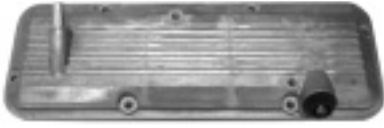

EQ-VC262

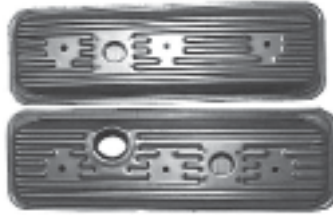

EQ-VC350M

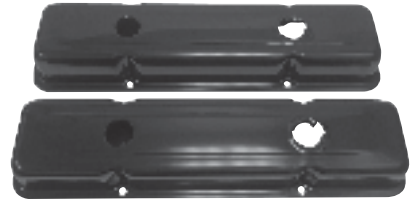

EQ-VC351L

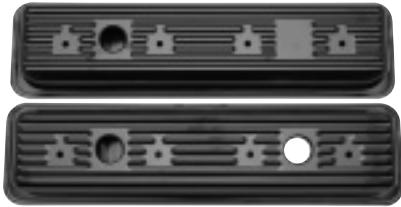

EQ-TCC305



EQ-TCC349



EQ-TCC350



EQ-TCC454



EQ-TM351A



EQ-TM454C



EQ-DT454C



EQ-DT460



EQ-PCV350



EQ-OC350N



| PART #    | DESCRIPTION                     | APPLICATION               | YEARS/NOTES                                                                       |
|-----------|---------------------------------|---------------------------|-----------------------------------------------------------------------------------|
| EQ-VC134N | VALVE COVER                     | GM 2.2L                   | 1995 - 1997                                                                       |
| EQ-VC262  | VALVE COVER SET                 | CHEVROLET 4.3L 262        | 1986 & UP - METAL                                                                 |
| EQ-VC350L | VALVE COVER SET                 | CHEVROLET SMALL BLOCK     | 1986 & UP - 1 BREATHER & 1 FILLER PER SIDE                                        |
| EQ-VC350M | VALVE COVER SET                 | CHEVY 305 5.0L/350 5.7    | 1970 - 1985 - METAL, OUTER BOLT DOWN HOLES<br>1 PUSH-IN HOLE & 1 TURN-IN CAP HOLE |
| EQ-VC351L | VALVE COVER SET                 | CHEVROLET SMALL BLOCK     | 1986 & UP 1 PUSH IN / 1 SCREW IN 1 PUSH IN                                        |
| EQ-VC352L | VALVE COVER SET                 | CHEVROLET SMALL BLOCK     | 1986 & UP 1 PUSH IN & 1 SCREW IN BOTH SIDES                                       |
| EQ-VC300N | VALVE COVER                     | FORD 4.9L 300 CID         | TALL FILLER NECK                                                                  |
| EQ-TCC305 | TIMING COVER BLK PAINTED        | CHEVROLET SMALL BLOCK     | 6-3/4" BALANCER TIMING MARK AT 12 O'CLOCK                                         |
| EQ-TCC349 | TIMING COVER BLK PAINTED        | CHEVROLET SMALL BLOCK     | NO TIMING MARK                                                                    |
| EQ-TCC350 | TIMING COVER BLK PAINTED        | CHEVROLET SMALL BLOCK     | 8" BALANCER TIMING MARK AT 12 O'CLOCK                                             |
| EQ-TM350  | TIMING COVER BLK PAINTED        | CHEVROLET SMALL BLOCK     | BOLT-ON TIMING MARKER                                                             |
| EQ-TM350C | TIMING COVER MARKER CHROMED     | CHEVROLET SMALL BLOCK     | BOLT-ON TIMING MARKER                                                             |
| EQ-TC350M | TIMING COVER BLK PAINTED        | CHEVROLET SMALL BLOCK     | 6-3/4" BALANCER TIMING MARK AT 2 O'CLOCK                                          |
| EQ-TC262P | TIMING COVER PLASTIC            | CHEVROLET 4.3L            | MARINE AND 96 & UP                                                                |
| EQ-TC350P | TIMING COVER PLASTIC            | CHEVROLET SMALL BLOCK     | 1996 - 2000 INCLUDES SENSOR HOLE PLUG                                             |
| EQ-TCC454 | TIMING COVER BLK PAINTED        | CHEVROLET BIG BLOCK       | 1968 - 1990                                                                       |
| EQ-TM351A | TIMING COVER MARKER             | FORD 302 5.0L / 351W 5.8L | 1969 - 1984 BOLT ON TIMING MARKER<br>USE WITH EQ-TC351 SERIES TIMING COVERS       |
| EQ-TM454C | TIMING COVER MARKER CHROMED     | CHEVROLET BIG BLOCK       | 1968 - 1990                                                                       |
| EQ-DT454C | DIPSTICK & TUBE CHROMED         | CHEVROLET BIG BLOCK       | 1968 - 1990                                                                       |
| EQ-DT460  | DIPSTICK TUBE                   | FORD 429 7.0L / 460 7.5L  | 1969 - 1997                                                                       |
| EQ-PCV350 | PCV GROMMET RUBBER              | PCV GROMMET RUBBER        | 1968 - 1990                                                                       |
| EQ-OC350N | SCREW IN OIL CAP SM BLOCK CHEVY | UNIVERSAL                 | 1986 & UP                                                                         |

# THE NAME YOU TRUST FOR ENGINE PARTS

## JAPANESE THREAD PIPE PLUGS

**EQ-JPP05A - Assortment Pack**  
Contains: 5 of each Size



**A "Must Have" For Toyota Crankshafts!**

Japanese Threads for Toyota & Mitsubishi Pipe Plugs Have Sealant On Threads.

| PART #       | SIZE      | STD PACK |
|--------------|-----------|----------|
| EQ-JPP001    | 1/8" - 28 | 25       |
| EQ-JPP002    | 1/4" - 19 | 25       |
| EQ-JPP002BLK | 1/4" - 19 | 500      |
| EQ-JPP003    | 3/8" - 19 | 25       |
| EQ-JPP003BLK | 3/8" - 19 | 500      |
| EQ-JPP004    | 1/2" - 14 | 25       |
| EQ-JPP005    | 3/4" - 14 | 25       |

## METRIC PIPE PLUGS

**EQ-MPP05A - Assortment Pack**  
Contains: 5 of each Size



**With Vibra-Seal Coating On Threads**

| PART #    | THREAD SIZE | HEIGHT | SOCKET DRIVE | SOCKET DEPTH | STD PACK |
|-----------|-------------|--------|--------------|--------------|----------|
| EQ-MPP001 | 8MM -1.0    | 8MM    | 4MM          | 4MM          | 25       |
| EQ-MPP002 | 10MM-1.0    | 8MM    | 5MM          | 4MM          | 25       |
| EQ-MPP003 | 12MM-1.5    | 10MM   | 6MM          | 5MM          | 25       |
| EQ-MPP004 | 14MM-1.5    | 10MM   | 7MM          | 5MM          | 25       |
| EQ-MPP005 | 16MM-1.5    | 10MM   | 8MM          | 5MM          | 25       |
| EQ-MPP006 | 18MM-1.5    | 10MM   | 8MM          | 5MM          | 25       |
| EQ-MPP007 | 20MM-1.5    | 10MM   | 10MM         | 5MM          | 25       |
| EQ-MPP008 | 22MM-1.5    | 10MM   | 10MM         | 5MM          | 25       |
| EQ-MPP009 | 24MM-1.5    | 12MM   | 12MM         | 6MM          | 25       |

## STANDARD PIPE PLUGS

**EQ-SPP25A - Assortment Pack**  
Contains: 25 of each Size



**With Vibra-Seal Coating On Threads**

| PART #    | SIZE          | STD PACK |
|-----------|---------------|----------|
| EQ-SPP062 | 1/16" X .300" | 50       |
| EQ-SPM062 | 1/16" X .300" | 1000     |
| EQ-SPP125 | 1/8" X .300"  | 50       |
| EQ-SPM125 | 1/8" X .300"  | 1000     |
| EQ-SPP250 | 1/4" X .375"  | 50       |
| EQ-SPM250 | 1/4" X .375"  | 1000     |
| EQ-SPP251 | 1/4" X .460"  | 50       |
| EQ-SPM251 | 1/4" X .460"  | 1000     |
| EQ-SPP375 | 3/8" X .375   | 50       |
| EQ-SPM375 | 3/8" X .375   | 1000     |
| EQ-SPP500 | 1/2" X .550"  | 25       |
| EQ-SPM500 | 1/2" X .550"  | 1000     |
| EQ-SPP750 | 3/4" X .550"  | 25       |

## SMOG PLUGS

| PART #    | DESCRIPTION                                                                         | STD PACK | EQ-FTP034 | EQ-SP300L |
|-----------|-------------------------------------------------------------------------------------|----------|-----------|-----------|
| EQ-SP300E | FORD 300 CID SMOG PLUG PRE '84-V8, 330, 360, 361HD, 390, 391HD-1/2"X20"X.55"        | 10       |           |           |
| EQ-SP300L | FORD 300 CID SMOG PLUG '84 AND UP-9/16" X 18 X .55"                                 | 10       |           |           |
| EQ-FTP034 | FORD V8 255, 302, 351C, 351M, 351W, 400 THERMALACTOR PLUG 5/8"-11" OD X 7/16"-14 ID | 25       |           |           |
| EQ-FTPBLK | FORD V8 255, 302, 351C, 351M, 351W, 400 THERMALACTOR PLUG 5/8"-11" OD X 7/16"-14 ID | 500      |           |           |

## OEM CONNECTING ROD

6.7L Ford Diesel OEM Connecting Rod  
OEM #HC3Q 6200AA

| PART #     | DESCRIPTION                                                          |
|------------|----------------------------------------------------------------------|
| EQ-CRF409D | FITS FORD DIESEL "F" SERIES TRUCKS FROM 2017 - 2019<br>35MM PIN BORE |

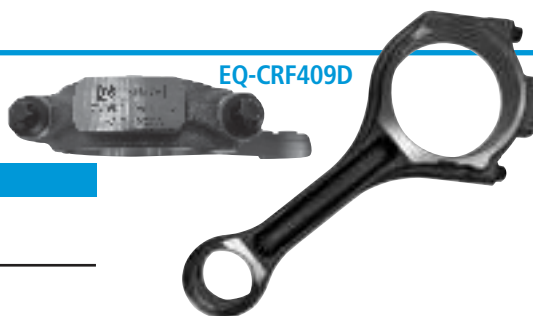

**Call Customer Service For Additional Applications!**

## DIPSTICK TUBE ADAPTORS

Chevrolet Adaptors Make Your Early Blocks Late!

*Opposite side dipstick adaptors convert Pre-1980 Chevy Small Blocks to 1980 thru 1985*

| PART #    | DESCRIPTION                               |
|-----------|-------------------------------------------|
| EQ-DA026P | BOLT-ON PAN RAIL (HAS ANGLED BOLT HOLES)  |
| EQ-DA027  | WELD-ON (WITH DIPSTICK TUBE HOLE DRILLED) |

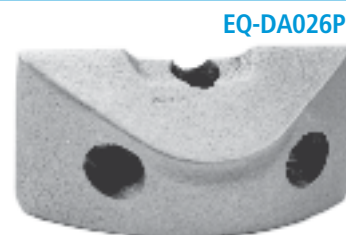

## CONVERSION REAR MAIN SEAL HOLDERS

Chevrolet 1986 - Up, V6 262 CID & V8 Small Block

*The choice is yours - use early or late style oil pan!*

**BEST ADAPTORS AVAILABLE!**



| PART #    | APPLICATION    | DESCRIPTION                                                                                                                     |
|-----------|----------------|---------------------------------------------------------------------------------------------------------------------------------|
| EQ-RSH349 | EARLY PAN      | ENABLES A REBUILDER TO INSTALL A 2-PC. DESIGN CRANKSHAFT IN A 1-PC. SEAL DESIGN APPLICATION. MANUFACTURED FROM BILLET ALUMINUM. |
| EQ-RSH350 | LATE PAN       | ENABLES A REBUILDER TO INSTALL A 2-PC. DESIGN CRANKSHAFT IN A 1-PC. SEAL DESIGN APPLICATION. MANUFACTURED FROM BILLET ALUMINUM. |
| EQ-AT350  | ALIGNMENT TOOL | FOR USE WITH EQ-RSH349 & EQ-RSH350 CONVERSION SEAL HOLDERS                                                                      |

# THE NAME YOU TRUST FOR ENGINE PARTS

## CAM THRUST PLATES

EQ-CP250N



EQ-CP301N



EQ-CP302N



EQ-CP349N



EQ-CP350N



EQ-CP460N



| PART #    | APPLICATION                                           | OEM #     | QTY       |
|-----------|-------------------------------------------------------|-----------|-----------|
| EQ-CP250N | CHEVROLET 230, 250, 292 (63-93), PONTIAC 151 (R CODE) | 10000568  | PACK OF 5 |
| EQ-CP301N | PONTIAC 301, 400, 455                                 |           | PACK OF 5 |
| EQ-CP302N | FORD 289, 302, 351W (67-86)                           | C90Z6269A | PACK OF 5 |
| EQ-CP349N | CHEVROLET 305, 350 3.90" TIP TO TIP                   |           | PACK OF 5 |
| EQ-CP350N | CHEVROLET 305, 350 4.23" TIP TO TIP ROLLER CAM        | 10168501  | PACK OF 5 |
| EQ-CP349N | 454 BIG BLOCK WITH ROLLER CAM                         |           | PACK OF 5 |
| EQ-CP460N | FORD 351M, 400, 429, 460 (68-91)                      | C8SZ6269A | PACK OF 5 |

## BLOCK & HEAD CONVERSION JIGS

EQ-CJ262

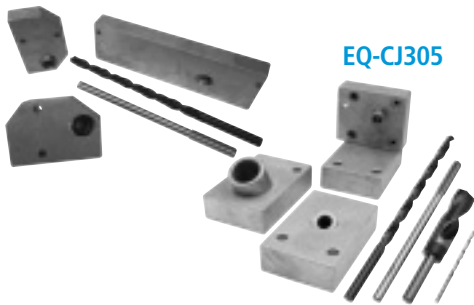

NOTE: ALL TOOLING NON-RETURNABLE

| PART #   | DESCRIPTION                                                                                                                  |
|----------|------------------------------------------------------------------------------------------------------------------------------|
| EQ-CJ262 | CONVERT CHEVROLET 4.3L 262 CID BLOCKS W/ELECTRIC FUEL PUMPS TO ACCEPT MECHANICAL FUEL PUMP (INCLUDES DRILL BITS AND REAMERS) |
| EQ-CJ305 | CONVERT CHEVROLET SMALL BLOCKS W/ELECTRIC FUEL PUMPS TO ACCEPT MECHANICAL FUEL PUMP (INCLUDES DRILL BITS AND REAMERS)        |

## ELIMINATION KITS

EQ-BEK122



EQ-JVE156



| PART #    | DESCRIPTION                                                                                                                                                                                                     |
|-----------|-----------------------------------------------------------------------------------------------------------------------------------------------------------------------------------------------------------------|
| EQ-BEK122 | BALANCE SHAFT CHRYSLER/MITSUBISHI 1.8L, 2.0L, 2.4L, G62B, G63B, 4G63B, G64B, 4G64B (BELT DRIVE APPLICATIONS)<br>KIT INCLUDES: UPPER & LOWER BUSHINGS, BALANCE SHAFT REPLACEMENT PIN, OIL GALLEY BLOCK-OFF PLUG. |
| EQ-JVE156 | JET VALVE CHRYSLER/MITSUBISHI 2.6L REPLACES JET VALVES IN CYLINDER HEADS FOR USE IN NON JET VALVE APPLICATIONS. FITS MANY OTHER APPLICATIONS WHERE OEM JET VALVE #MD009440 IS USED.                             |

## CYLINDER HEAD ADAPTORS

EQ-AH034  
Add a 7th Hole

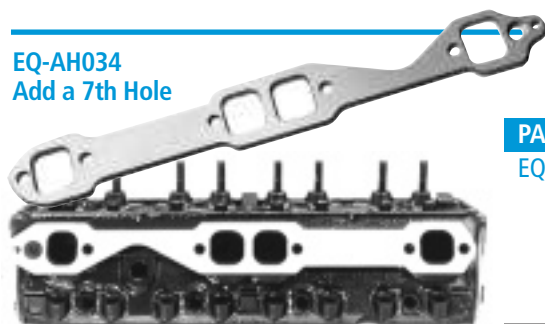

One Of The First Items We Designed To Help Rebuilders Solve Their Problems!

| PART #   | DESCRIPTION                                                                                                                                                                         |
|----------|-------------------------------------------------------------------------------------------------------------------------------------------------------------------------------------|
| EQ-AH034 | CYLINDER HEAD ADAPTOR<br>USE EARLY SMALL BLOCK CHEVROLET HEADS WITH 6 EXHAUST BOLT HOLES IN PLACE OF 7 BOLT HOLE HEADS. NO NEED TO SELL YOUR CUSTOMER A DIFFERENT HEAD OR MANIFOLD. |

## INTAKE MANIFOLD

- 4 Barrel Universal Carburetor mounting
- 15 degree carb flange
- All required mounting & accessories holes are tapped
- Superior runner finish for increased air flow
- CNC machined for exact fit & bolt hole location
- Manufactured of the highest grade of cast iron to resist salt water corrosion that aluminum intakes experience & corrosion caused by Natural gas and other dry fuels
- Electric Choke



| PART #     | MFG       | CID | LITER | YEARS       | CROSS REFERENCE |
|------------|-----------|-----|-------|-------------|-----------------|
| EQ-IN350MB | CHEVROLET | 305 | 5.0   | 1987 - 1995 |                 |
| EQ-IN350MB | CHEVROLET | 350 | 5.7   | 1987 - 1995 |                 |
| EQ-IN350MA | CHEVROLET | 305 | 5.0   | 1996 - 2002 | 17618T          |
| EQ-IN350MA | CHEVROLET | 350 | 5.7   | 1996 - 2002 | 17618T          |

## INTAKE MANIFOLD PLUG KIT

All The Pipe Plugs Needed To Block The Threaded Holes  
In IN350MA & IN350MB

PKIN350

| PART #     | MFG       | CID | LITER | YEARS | ITEM          |
|------------|-----------|-----|-------|-------|---------------|
| EQ-PKIN350 | CHEVROLET | 350 | 5.7   | ALL   | PIPE PLUG KIT |



## EXHAUST MANIFOLDS

| PART #    | MFG  | VEHICLE | ENGINE | LITER | YEARS       | SIDE  | EQ-EN1698 | EQ-EN1699 |
|-----------|------|---------|--------|-------|-------------|-------|-----------|-----------|
| EQ-EN1698 | FORD | TRUCK   | 460    | 7.5   | 1988 - 1997 | RIGHT |           |           |
| EQ-EN1699 | FORD | TRUCK   | 460    | 7.5   | 1988 - 1997 | LEFT  |           |           |



## SIDE COVER - PUSH ROD

EQ-SP181N

EQ-FSP300N



| PART #     | MFG   | VEHICLE                        | ENG | LITERS | YEARS       | CASTING/OEM#                                       |
|------------|-------|--------------------------------|-----|--------|-------------|----------------------------------------------------|
| EQ-SP181N  | CHEVY | CAR, TRUCK, MARINE, INDUSTRIAL | 153 | 2.5    | ALL         | 93423830 / 59341A1                                 |
| EQ-SP181N  | CHEVY | CAR, TRUCK, MARINE, INDUSTRIAL | 181 | 3.0    | ALL         | 93423830 / 59341A1                                 |
| EQ-FSP300N | FORD  | TRUCK & INDUSTRIAL             | 240 | 4.9    | 1965 - 1974 | E7TZ-6519-A, E5TZ-6519-B, C5AZ-6519-C, C5AZ-6519-B |
| EQ-FSP300N | FORD  | TRUCK & INDUSTRIAL             | 300 | 4.9    | 1965 - 1996 | E7TZ-6519-A, E5TZ-6519-B, C5AZ-6519-C, C5AZ-6519-B |



# THE NAME YOU TRUST FOR ENGINE PARTS

## TIMING COVERS

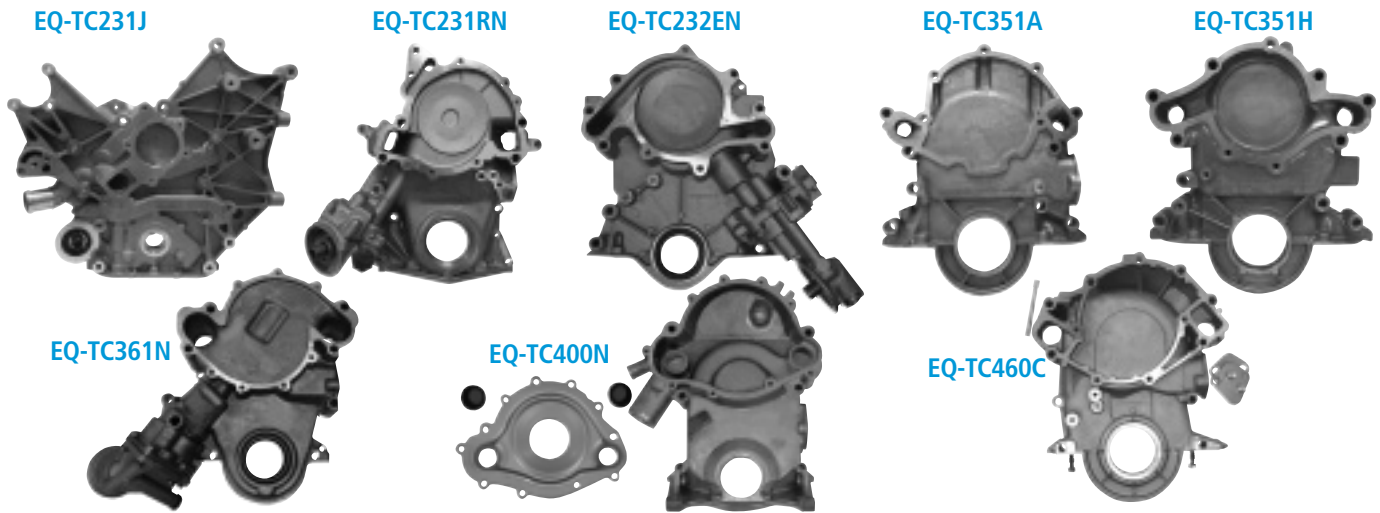

## AMC / JEEP TIMING COVERS

| PART #    | MFG      | VEHICLE  | ENG | LITERS | YEARS | CASTING / OEM     | NOTES                                          | HOLLANDER         |
|-----------|----------|----------|-----|--------|-------|-------------------|------------------------------------------------|-------------------|
| EQ-TC231J | CHRYSLER | WRANGLER | 230 | 3.8    | 07-11 | 04666020AA        | OEM # 68003438AC,<br>68003438AA,<br>68003438AB | 308-640           |
| EQ-TC361N | AMC      |          | 290 | 4.7    | 66-69 | J8129373, 3226242 |                                                | 308-214A, B, C, D |
| EQ-TC361N | AMC      |          | 304 | 5.0    | 70-81 | J8129373, 3226242 |                                                | 308-214A, B, C, D |
| EQ-TC361N | AMC      |          | 343 | 5.6    | 67-69 | J8129373, 3226242 |                                                | 308-214A, B, C, D |
| EQ-TC361N | AMC      |          | 360 | 5.9    | 70-91 | J8129373, 3226242 |                                                | 308-214A, B, C, D |
| EQ-TC361N | AMC      |          | 390 | 6.4    | 68-70 | J8129373, 3226242 |                                                | 308-214A, B, C, D |
| EQ-TC361N | AMC      |          | 401 | 6.6    | 70-78 | J8129373, 3226242 |                                                | 308-214A, B, C, D |

## BUICK TIMING COVERS

| PART #     | MFG   | VEHICLE | ENG | LITERS | YEARS | CASTING / OEM | NOTES           | HOLLANDER |
|------------|-------|---------|-----|--------|-------|---------------|-----------------|-----------|
| EQ-TC231RN | BUICK | RWD CAR | 231 | 3.8    | 78-84 |               | 14 BOLT OIL PAN | 308-208   |
| EQ-TC231RN | BUICK | RWD CAR | 231 | 3.8    | 85-87 | 25522651      | 20 BOLT OIL PAN | 308-209   |
| EQ-TC231RN | BUICK | RWD CAR | 252 | 4.1    | 80-84 |               | 14 BOLT OIL PAN | 308-208   |

## CHEVROLET TIMING COVERS

| PART #    | MFG   | VEHICLE                             | ENG | LITERS | YEARS | CASTING / OEM                   | NOTES               | HOLLANDER |
|-----------|-------|-------------------------------------|-----|--------|-------|---------------------------------|---------------------|-----------|
| EQ-TC173A | CHEVY | S10                                 | 173 | 2.8    | 82-86 | 14100617, 12509037              |                     |           |
| EQ-TC173B | CHEVY | S10, BLAZER,<br>CAMARO,<br>FIREBIRD | 173 | 2.8    | 87-92 | 14090537, 10049009              |                     | 308-137   |
| EQ-TC173C | CHEVY | BLAZER, S10,<br>CAMARO,<br>FIREBIRD | 173 | 2.8    | 82-86 | 14024263, 14033526,<br>14048323 |                     | 308-136   |
| EQ-TC181N | CHEVY | MARINE -<br>INDUSTRIAL              | 181 | 3.0    | 63-89 | 3923456, 5934141A1,<br>49951    | INDUSTRIAL & MARINE |           |
| EQ-TC173B | CHEVY | CAMARO,<br>FIREBIRD                 | 189 | 3.1    | 90-92 | 14090537, 10049009              |                     | 308-137   |

CHEVROLET TIMING COVERS CONTINUED ON PAGE 26



## CHEVROLET TIMING COVERS (continued)

| PART #    | MFG   | VEHICLE     | ENG | LITERS | YEARS | CASTING / OEM      | NOTES                                              | HOLLANDER    |
|-----------|-------|-------------|-----|--------|-------|--------------------|----------------------------------------------------|--------------|
| EQ-TC262P | CHEVY | CAR & TRUCK | 262 | 4.3    | 96-03 | 12554555, 12554557 | WITH OPEN SENSOR HOLE (INCLUDES PLUG)              | 308-434      |
| EQ-TC262P | CHEVY | MARINE      | 262 | 4.3    | 96-UP | 12554555, 12554557 | WITH OPEN SENSOR HOLE (INCLUDES PLUG)              | 308-434      |
| EQ-TCC305 | CHEVY | CAR & TRUCK | 305 | 5.0    | 69-95 | 12531283, 12523974 | METAL FOR 6-3/4" BALANCER                          | 305-130, 131 |
| EQ-TCC349 | CHEVY | CAR & TRUCK | 305 | 5.0    | 69-95 | 10243967           | METAL - BLACK PAINTED TIMING COVER, BOLT-ON MARKER |              |
| EQ-TC350M | CHEVY | MARINE      | 305 | 5.0    | 69-UP |                    | METAL FOR 6-3/4" BALANCER                          |              |
| EQ-TC350P | CHEVY | CAR & TRUCK | 305 | 5.0    | 96-02 | 12558343, 12562818 | WITH OPEN SENSOR HOLE (INCLUDES PLUG)              | 308-436      |
| EQ-TC350P | CHEVY | MARINE      | 305 | 5.0    | 96-UP | 12558343, 12562818 | WITH OPEN SENSOR HOLE (INCLUDES PLUG)              | 308-436      |
| EQ-TM350  | CHEVY | CAR & TRUCK | 305 | 5.0    | 67-95 |                    | TIMING MARKER - BLACK PAINTED                      |              |
| EQ-TM350  | CHEVY | MARINE      | 305 | 5.0    | 67-95 |                    | TIMING MARKER - BLACK PAINTED                      |              |
| EQ-TM350C | CHEVY | CAR & TRUCK | 350 | 5.7    | 67-95 |                    | TIMING MARKER CHROME                               |              |
| EQ-TM350C | CHEVY | MARINE      | 350 | 5.7    | 67-95 |                    | TIMING MARKER CHROME                               |              |
| EQ-TCC305 | CHEVY | CAR & TRUCK | 350 | 5.7    | 69-96 | 12531283, 12523974 | METAL FOR 6-3/4" BALANCER                          | 305-130, 131 |
| EQ-TCC349 | CHEVY | CAR & TRUCK | 350 | 5.7    | 69-95 | 10243967           | METAL - BLACK PAINTED TIMING COVER, BOLT-ON MARKER |              |
| EQ-TCC350 | CHEVY | CAR & TRUCK | 350 | 5.7    | 67-95 | 10243963           | METAL FOR 8" BALANCER BLACK PAINTED                | 308-128      |
| EQ-TC350M | CHEVY | MARINE      | 350 | 5.7    | 69-UP |                    | TIMING MARKER - METAL FOR 6-3/4" BALANCER          |              |
| EQ-TC350P | CHEVY | CAR & TRUCK | 350 | 5.7    | 96-02 | 12558343, 12562818 | WITH OPEN SENSOR HOLE (INCLUDES PLUG)              | 308-436      |
| EQ-TC350P | CHEVY | MARINE      | 350 | 5.7    | 96-UP | 12558343, 12562818 | WITH OPEN SENSOR HOLE (INCLUDES PLUG)              | 308-436      |
| EQ-TM350  | CHEVY | CAR & TRUCK | 350 | 5.7    | 67-95 |                    | TIMING MARKER - BLACK PAINTED                      |              |
| EQ-TM350  | CHEVY | MARINE      | 350 | 5.7    | 67-95 |                    | TIMING MARKER - BLACK PAINTED                      |              |
| EQ-TM350C | CHEVY | CAR & TRUCK | 350 | 5.7    | 67-95 |                    | TIMING MARKER CHROME                               |              |
| EQ-TM350C | CHEVY | MARINE      | 350 | 5.7    | 67-95 |                    | TIMING MARKER CHROME                               |              |
| EQ-TCC350 | CHEVY | CAR & TRUCK | 400 | 6.6    | 70-80 | 10243963           | METAL FOR 8" BALANCER                              | 308-128      |
| EQ-TCC454 | CHEVY | CAR & TRUCK | 396 | 6.5    | 65-70 | 3885048, 330850    | METAL - BLACK PAINTED                              | 308-158A, B  |
| EQ-TM454C | CHEVY | CAR & TRUCK | 396 | 6.5    | 65-70 | 3885048, 330850    | TIMING MARKER CHROME                               |              |
| EQ-TCC454 | CHEVY | CAR & TRUCK | 427 | 7.0    | 68-90 | 3885048, 330850    | METAL - BLACK PAINTED                              | 308-158A, B  |
| EQ-TM454C | CHEVY | CAR & TRUCK | 427 | 7.0    | 68-90 | 3885048, 330850    | TIMING MARKER CHROME                               |              |
| EQ-TCC454 | CHEVY | CAR & TRUCK | 454 | 7.4    | 68-90 | 3885048, 330850    | METAL - BLACK PAINTED                              | 308-158A, B  |
| EQ-TM454C | CHEVY | CAR & TRUCK | 454 | 7.4    | 68-90 | 3885048, 330850    | TIMING MARKER CHROME                               |              |

## CHRYSLER, DODGE, MOPAR TIMING COVERS

| PART #    | MFG      | VEHICLE          | ENG | LITERS | YEARS | CASTING / OEM    | NOTES                                    | HOLLANDER   |
|-----------|----------|------------------|-----|--------|-------|------------------|------------------------------------------|-------------|
| EQ-TC231J | CHRYSLER | WRANGLER         | 230 | 3.8    | 07-11 | 04666020AA       | OEM # 68003438AC, 68003438AA, 68003438AB | 308-640     |
| EQ-TC318N | CHRYSLER | TRUCK            | 239 | 3.9    | 87-91 | 2951698, 3769966 | 3-3/16" SEAL HOLE                        | 308-245A, B |
| EQ-TC318N | CHRYSLER | CAR, TRUCK & VAN | 318 | 5.2    | 70-91 | 2951698, 3769966 | 3-3/16" SEAL HOLE                        | 308-245A, B |
| EQ-TC318N | CHRYSLER | CAR              | 340 | 5.6    | 70-73 | 2951698, 3769966 | 3-3/16" SEAL HOLE                        | 308-245A, B |
| EQ-TC318N | CHRYSLER | CAR, TRUCK & VAN | 360 | 5.9    | 70-91 | 2951698, 3769966 | 3-3/16" SEAL HOLE                        | 308-245A, B |

# THE NAME YOU TRUST FOR ENGINE PARTS

## FORD TIMING COVERS

| PART #     | MFG  | VEHICLE                  | ENG  | LITERS | YEARS | CASTING / OEM                                             | NOTES                                                          | HOLLANDER         |
|------------|------|--------------------------|------|--------|-------|-----------------------------------------------------------|----------------------------------------------------------------|-------------------|
| EQ-TC141I  | FORD | CAR & TRUCK              | 122  | 2.0    | 74-88 | D4FZ6019C, E3ZZ6019B                                      | PLASTIC - INNER                                                | 308-274           |
| EQ-TC141I  | FORD | CAR & TRUCK              | 140  | 2.3    | 74-88 | D4FZ6019C, E3ZZ6019B                                      | PLASTIC - INNER                                                | 308-274           |
| EQ-TC142I  | FORD | CAR & TRUCK              | 140  | 2.3    | 89-94 | F3ZZ6019B,<br>F8DZ6019AA                                  | PLASTIC - INNER /<br>SENSOR LOWER LEFT,<br>BELT TENSIONER LEFT | 308-327           |
| EQ-TC232DN | FORD | CAR & TRUCK              | 232  | 3.8    | 88-93 | E7DE6059FA,<br>D9DE6059BB                                 |                                                                | 308-350A          |
| EQ-TC232DN | FORD | CAR & TRUCK              | 232  | 3.8    | 94-95 | F46E6059BA                                                | WITH ECC MOUNT                                                 | 308-350B          |
| EQ-TC232EN | FORD | CAR & TRUCK              | 232  | 3.8    | 96-99 | F65E6059AE,<br>F65E6E008AD, F65AD,<br>F75E6F008AA, F75AED | COMPLETE WITH OIL PUMP                                         | 308-451           |
| EQ-TC300N  | FORD | TRUCK & VAN              | 240  | 3.9    | 65-97 | E5TE6019H                                                 |                                                                | 308-296           |
| EQ-TC232EN | FORD | CAR & TRUCK              | 256  | 4.2    | 97-05 | F65E6059AE,<br>F65E6E008AD, F65AD,<br>F75E6F008AA, F75AED | COMPLETE WITH OIL PUMP                                         | 308-451           |
| EQ-TC300N  | FORD | TRUCK & VAN              | 300  | 4.9    | 65-97 | E5TE6019H                                                 |                                                                | 308-296           |
| EQ-TM351A  | FORD | CAR, TRUCK<br>& VAN      | 302  | 5.0    | 69-84 | F1TZ6023A                                                 | BOLT ON TIMING MARKER                                          |                   |
| EQ-TC351A  | FORD | CAR, TRUCK<br>& VAN      | 302  | 5.0    | 69-84 | D4OE, D7AE, D9TE                                          |                                                                | 308-302A, B       |
| EQ-TC351C  | FORD | CAR, TRUCK<br>& VAN      | 302  | 5.0    | 83-86 | E0AE, E3AE6059CA                                          | WITH ECC MOUNT                                                 | 308-460A          |
| EQ-TC351E  | FORD | COUGAR,<br>THUNDERBIRD   | 302  | 5.0    | 91-93 | E5AE, E8AE                                                | WITH ELECTRIC FUEL<br>PUMP MOUNT                               | 308-323           |
| EQ-TC351F  | FORD | TRUCK & VAN              | 302  | 5.0    | 87-97 | E7TE6059BA, F6TE6059NA                                    |                                                                | 308-313A, B       |
| EQ-TC351H  | FORD | EXPLORER,<br>MOUNTAINEER | 302  | 5.0    | 96-01 | F67Z6019AA, F1SE6059BC,<br>F87E6059AA                     |                                                                | 308-457           |
| EQ-TC351H  | FORD | MUSTANG                  | 302  | 5.0    | 94-95 | F67Z6019AA, F1SE6059BC,<br>F87E6059AA                     |                                                                | 308-457           |
| EQ-TM351A  | FORD | CAR, TRUCK<br>& VAN      | 351W | 5.8    | 69-84 | F1TZ6023A                                                 | BOLT ON TIMING MARKER                                          |                   |
| EQ-TC351A  | FORD | CAR, TRUCK<br>& VAN      | 351W | 5.8    | 69-84 | D4OE, D7AE, D9TE                                          |                                                                | 308-302A, B       |
| EQ-TC351C  | FORD | CAR, TRUCK<br>& VAN      | 351W | 5.8    | 83-86 | E0AE, E3AE6059CA                                          | WITH ECC MOUNT                                                 | 308-460A          |
| EQ-TC351F  | FORD | TRUCK & VAN              | 351W | 5.8    | 87-97 | E7TE6059BA, F6TE6059NA                                    |                                                                | 308-313A, B       |
| EQ-DT460   | FORD | CAR, TRUCK<br>& VAN      | 429  | 7.0    | 69-78 | C8SZ6754A                                                 | DIPSTICK TUBE                                                  |                   |
| EQ-TC460N  | FORD | CAR, TRUCK<br>& VAN      | 429  | 7.0    | 69-78 | E8TE6059AA                                                |                                                                | 308-309, 312, 410 |
| EQ-TC460N  | FORD | TRUCK & VAN              | 460  | 7.5    | 69-97 | E8TE6059AA                                                |                                                                | 308-309, 312, 410 |
| EQ-DT460   | FORD | TRUCK & VAN              | 460  | 7.5    | 69-97 | C8SZ6754A                                                 | DIPSTICK TUBE                                                  |                   |
| EQ-TC460C  | FORD | TRUCK & VAN              | 460  | 7.5    | 69-97 | F6TZ6019MA                                                | CALIFORNIA EMISSIONS                                           |                   |

## ISUZU TIMING COVERS

| PART #    | MFG   | VEHICLE | ENG | LITERS | YEARS | CASTING / OEM      | NOTES | HOLLANDER |
|-----------|-------|---------|-----|--------|-------|--------------------|-------|-----------|
| EQ-TC173B | ISUZU | TROOPER | 173 | 2.8    | 89-91 | 14090537, 10049009 |       | 308-137   |
| EQ-TC173B | ISUZU | RODEO   | 173 | 2.8    | 89-91 | 14090537, 10049009 |       | 308-137   |
| EQ-TC173B | ISUZU | RODEO   | 189 | 3.1    | 91-92 | 14090537, 10049009 |       | 308-137   |
| EQ-TC173B | ISUZU | PICKUP  | 189 | 3.1    | 91-94 | 14090537, 10049009 |       | 308-137   |
| EQ-TC173B | ISUZU | TROOPER | 189 | 3.1    | 91-94 | 14090537, 10049009 |       | 308-137   |

## PONTIAC TIMING COVERS

| PART #    | MFG     | VEHICLE | ENG       | LITERS    | YEARS | NOTES                                                  | HOLLANDER |
|-----------|---------|---------|-----------|-----------|-------|--------------------------------------------------------|-----------|
| EQ-TC400N | PONTIAC | CAR     | 301       | 4.9       | 69-77 | WITH WATER PUMP BACKING PLATE & (2) WATER TUBE INSERTS | 308-141   |
| EQ-TC400N | PONTIAC | CAR     | 350       | 5.7       | 69-77 | WITH WATER PUMP BACKING PLATE & (2) WATER TUBE INSERTS | 308-141   |
| EQ-TC400N | PONTIAC | CAR     | 400       | 6.6       | 69-77 | WITH WATER PUMP BACKING PLATE & (2) WATER TUBE INSERTS | 308-141   |
| EQ-TC400N | PONTIAC | CAR     | 455       | 7.5       | 70-76 | WITH WATER PUMP BACKING PLATE & (2) WATER TUBE INSERTS | 308-141   |
| EQ-WP400P | PONTIAC | CAR     | ALL ABOVE | ALL ABOVE | 69-77 | WATER PUMP BACKING PLATE                               |           |
| EQ-WP400S | PONTIAC | CAR     | ALL ABOVE | ALL ABOVE | 69-77 | WATER TUBE INSERT (SOLD EACH)                          |           |

## TOYOTA TIMING COVERS

| PART #    | MFG    | VEHICLE | ENG   | LITERS | YEARS | CASTING / OEM | NOTES        | HOLLANDER |
|-----------|--------|---------|-------|--------|-------|---------------|--------------|-----------|
| EQ-TC22RN | TOYOTA | TRUCK   | 22REC | 2.4    | 85-96 | 11302-35010   | 11-1/8" TALL | 308-58033 |

## HEAD BOLT SETS

### SET DOES ENTIRE ENGINE

EQ-HB121N



EQ-HB144N



EQ-HB259N



EQ-HB349NA



EQ-HB350P



EQ-HB454N



# THE NAME YOU TRUST FOR ENGINE PARTS

## HEAD BOLT SETS: SET DOES ENTIRE ENGINE

## CHEVROLET HEAD BOLTS

| PART #     | TTY | MFG       | LITERS | CID | YEARS | NOTES                            |
|------------|-----|-----------|--------|-----|-------|----------------------------------|
| EQ-HB262N  |     | CHEVROLET | 4.3    | 262 | 85-97 | WITHOUT SHOULDER                 |
| EQ-HB263N  |     | CHEVROLET | 4.3    | 262 | 97-06 | WITH SHOULDER                    |
| EQ-HB350N  |     | CHEVROLET | 4.6    | 283 | 57-67 | SMALL BLOCK V8                   |
| EQ-HB349NA | Y   | CHEVROLET | 4.8    | 294 | 98-18 | TRUCK                            |
| EQ-HB349NB | Y   | CHEVROLET | 4.8    | 294 | 04-09 | FULL THREAD BOLTS                |
| EQ-HB349NC | Y   | CHEVROLET | 4.8    | 294 | 04-14 |                                  |
| EQ-HB350N  |     | CHEVROLET | 5.0    | 305 | 80-97 | SMALL BLOCK V8                   |
| EQ-HB350P  |     | CHEVROLET | 5.0    | 305 | 80-97 | 180,000 PSI MATERIAL / 1/2" HEAD |
| EQ-HB349NA | Y   | CHEVROLET | 5.3    | 325 | 98-18 |                                  |
| EQ-HB349NB | Y   | CHEVROLET | 5.3    | 325 | 04-09 | FULL THREAD BOLTS                |
| EQ-HB349NC | Y   | CHEVROLET | 5.3    | 325 | 04-09 |                                  |
| EQ-HB350N  |     | CHEVROLET | 5.3    | 327 | 62-69 | SMALL BLOCK V8                   |
| EQ-HB349NA | Y   | CHEVROLET | 5.7    | 346 | 97-03 |                                  |
| EQ-HB350N  |     | CHEVROLET | 5.7    | 350 | 66-97 | SMALL BLOCK V8 - 5/8" HEX HEAD   |
| EQ-HB350P  |     | CHEVROLET | 5.7    | 350 | 66-97 | 180,000 PSI MATERIAL / 1/2" HEAD |
| EQ-HB349NA | Y   | CHEVROLET | 6.0    | 364 | 99-03 |                                  |
| EQ-HB349NB | Y   | CHEVROLET | 6.0    | 364 | 04-10 | FULL THREAD BOLTS                |
| EQ-HB349NC | Y   | CHEVROLET | 6.0    | 364 | 07-16 |                                  |
| EQ-HB454N  |     | CHEVROLET | 6.0    | 366 | 66-94 | BIG BLOCK V8                     |
| EQ-HB381N  |     | CHEVROLET | 6.2    | 381 | 82-93 | DIESEL                           |
| EQ-HB349NA | Y   | CHEVROLET | 6.2    | 381 | 98-18 |                                  |
| EQ-HB349NB | Y   | CHEVROLET | 6.2    | 381 | 04-09 | FULL THREAD BOLTS                |
| EQ-HB349NC | Y   | CHEVROLET | 6.2    | 381 | 04-14 |                                  |
| EQ-HB381N  |     | CHEVROLET | 6.5    | 395 | 92-01 | DIESEL                           |
| EQ-HB454N  |     | CHEVROLET | 6.5    | 396 | 70-72 | BIG BLOCK V8                     |
| EQ-HB350N  |     | CHEVROLET | 6.6    | 400 | 70-80 | SMALL BLOCK V8 - 5/8" HEX HEAD   |
| EQ-HB350N  |     | CHEVROLET | 6.6    | 400 | 70-80 | 180,000 PSI MATERIAL / 1/2" HEAD |
| EQ-HB454N  |     | CHEVROLET | 7.0    | 427 | 66-94 | BIG BLOCK V8                     |
| EQ-HB454N  |     | CHEVROLET | 7.4    | 454 | 70-98 | BIG BLOCK V8                     |
| EQ-HB454N  |     | CHEVROLET | 8.2    | 502 | 90-98 |                                  |
| EQ-HB496N  |     | CHEVROLET | 8.1    | 496 | 01-06 |                                  |

## CHRYSLER / DODGE HEAD BOLTS

| PART #    | TTY | MFG      | LITERS | CID    | YEARS | NOTES         |
|-----------|-----|----------|--------|--------|-------|---------------|
| EQ-HB121N |     | CHRYSLER | 2.0    | 1997CC | 90-92 | 4G63          |
| EQ-HB121N |     | CHRYSLER | 2.4    | 2350CC | 93-99 | 4G64          |
| EQ-HB156N |     | CHRYSLER | 2.6    | 2600CC | 81-90 | 5G54          |
| EQ-HB226N |     | CHRYSLER | 3.7    | 226    | 02-12 |               |
| EQ-HB239N |     | CHRYSLER | 3.9    | 239    | 92-03 | VIN. X MAGNUM |
| EQ-HB287N |     | CHRYSLER | 4.7    | 287    | 99-10 |               |
| EQ-HB318N |     | CHRYSLER | 5.2    | 318    | 92-04 | MAGNUM        |
| EQ-HB318N |     | CHRYSLER | 5.9    | 360    | 92-03 | MAGNUM        |



## FORD HEAD BOLTS

### HEAD BOLT SETS: SET DOES ENTIRE ENGINE

| PART #    | TTY | MFG  | LITERS | CID | YEARS | NOTES             |
|-----------|-----|------|--------|-----|-------|-------------------|
| EQ-HB140N |     | FORD | 2.3    | 140 | 74-97 | OHC               |
| EQ-HB171N |     | FORD | 2.8    | 171 | 76-87 | CAR & TRUCK       |
| EQ-HB177N | Y   | FORD | 2.9    | 177 | 86-90 |                   |
| EQ-HB177N | Y   | FORD | 4.0    | 244 | 90-01 |                   |
| EQ-HB280N | Y   | FORD | 4.6    | 250 | 91-04 | SOHC / DOHC       |
| EQ-HB302N | Y   | FORD | 5.0    | 302 | 70-01 |                   |
| EQ-HB280N | Y   | FORD | 5.4    | 330 | 97-04 | SOHC              |
| EQ-HB370N |     | FORD | 6.1    | 370 | 79-91 | TRUCK VIN. H      |
| EQ-HB413N |     | FORD | 6.8    | 413 | 97-03 | V10 VIN. S        |
| EQ-HB370N |     | FORD | 7.0    | 429 | 79-91 | TRUCK / PASSENGER |
| EQ-HB370N |     | FORD | 7.5    | 460 | 68-99 | VIN. L / G        |

## JEEP HEAD BOLTS

| PART #    | TTY | MFG  | LITERS | CID | YEARS | NOTES                                                  |
|-----------|-----|------|--------|-----|-------|--------------------------------------------------------|
| EQ-HB150N |     | JEEP | 2.5    | 150 | 83-96 | 1/2" BOLTS - HEAD CASTING 403 OR 117                   |
| EQ-HB226N |     | JEEP | 3.7    | 226 | 02-12 | LIBERTY, GRAND CHEROKEE                                |
| EQ-HB244N |     | JEEP | 4.0    | 244 | 96-06 | TJ, WRANGLER, GRAND CHEROKEE, CHEROKEE                 |
| EQ-HB259N |     | JEEP | 4.0    | 242 | 86-96 | 1/2" BOLTS                                             |
| EQ-HB259N |     | JEEP | 4.2    | 258 | 86-96 | 1/2" BOLTS                                             |
| EQ-HB287N |     | JEEP | 4.7    | 287 | 99-09 | DAKOTA, RAM, DURANGO, COMMANDER, GRAND CHEROKEE, ASPEN |

## MAZDA HEAD BOLTS

| PART #    | TTY | MFG   | LITERS | CID    | YEARS | NOTES                |
|-----------|-----|-------|--------|--------|-------|----------------------|
| EQ-HB177N |     | MAZDA | 4.0    | 4015CC | 91-00 | VIN. X, 8X, ZL (OHC) |

## MITSUBISHI HEAD BOLTS

| PART #    | TTY | MFG        | LITERS | CID | YEARS | NOTES                                      |
|-----------|-----|------------|--------|-----|-------|--------------------------------------------|
| EQ-HB121N |     | MITSUBISHI | 2.0    | 122 | 90-92 | M11 X 1.25 X 118 WITH CAPTURED WASHER 4G63 |
| EQ-HB121N |     | MITSUBISHI | 2.4    | 143 | 93-99 | M11 X 1.25 X 118 WITH CAPTURED WASHER 4G64 |
| EQ-HB156N |     | MITSUBISHI | 2.6    | 156 | 81-90 | 4G54                                       |

## TOYOTA HEAD BOLTS

| PART #    | TTY | MFG    | LITERS | CID    | YEARS | NOTES       |
|-----------|-----|--------|--------|--------|-------|-------------|
| EQ-HB144N |     | TOYOTA | 2.4    | 2366CC | 85-96 | 22REC       |
| EQ-HB179N | Y   | TOYOTA | 3.0    | 2959CC | 88-95 | 3VZE SOHC   |
| EQ-HB206N |     | TOYOTA | 3.4    | 3377CC | 95-01 | 5VZFE TRUCK |

# THE NAME YOU TRUST FOR ENGINE PARTS

## MARINE COMPONENTS

EQ-VC351L



EQ-CH262NO



EQ-TC350P



EQ-TCC350



EQ-TC350M



EQ-CH305BA



EQ-CH454CA



EQ-HB262N



EQ-WTC350N



EQ-OP350N

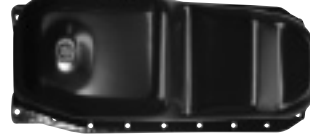

EQ-OP454



## ROCKER ARM VALVE COVERS

| PART #    | ENG MFG   | CID | LITERS | YEARS       | NOTES                                                                 | MERCUISER / QUICK SILVER CROSS REFERENCE |
|-----------|-----------|-----|--------|-------------|-----------------------------------------------------------------------|------------------------------------------|
| EQ-VC262  | CHEVROLET | 262 | 4.3    | 1985 - 1993 | METAL                                                                 | 14252, 814504                            |
| EQ-VC350M | CHEVROLET | 305 | 5.0    | 1970 - 1985 | METAL<br>OUTER BOLT DOWN HOLES<br>1 PUSH-IN HOLE & 1 TURN-IN CAP HOLE | 523331A1, 58211, 79961, 79961T1          |
| EQ-VC350M | CHEVROLET | 350 | 5.7    | 1970 - 1985 | METAL<br>OUTER BOLT DOWN HOLES<br>1 PUSH-IN HOLE & 1 TURN-IN CAP HOLE | 523331A1, 58211, 79961, 79961T1          |
| EQ-VC351L | CHEVROLET | 305 | 5.0    | 1986 - 1996 | METAL<br>CENTER BOLT DOWN HOLES<br>1 PUSH-IN & 1 SCREW-IN, 1 PUSH-IN  |                                          |
| EQ-VC351L | CHEVROLET | 350 | 5.7    | 1986 - 1996 | METAL<br>CENTER BOLT DOWN HOLES<br>1 PUSH-IN & 1 SCREW-IN, 1 PUSH-IN  |                                          |
| EQ-VC352L | CHEVROLET | 305 | 5.0    | 1986 - 1996 | METAL<br>CENTER BOLT DOWN HOLES<br>1 PUSH-IN & 1 SCREW-IN             | 809995                                   |
| EQ-VC352L | CHEVROLET | 350 | 5.7    | 1986 - 1996 | METAL<br>CENTER BOLT DOWN HOLES<br>1 PUSH-IN & 1 SCREW-IN             | 809995                                   |
| EQ-VC454  | CHEVROLET | 427 | 7.0    | 1969 - 1974 | METAL                                                                 | 17671                                    |
| EQ-VC454  | CHEVROLET | 454 | 7.4    | 1969 - 1990 | METAL                                                                 | 17671                                    |

## CAPS AND GROMMETS

EQ-OC350N



| PART #    | ENG MFG   | YEARS     | NOTES                                         | MERCUISER / QUICK SILVER CROSS REFERENCE |
|-----------|-----------|-----------|-----------------------------------------------|------------------------------------------|
| EQ-OC350N | CHEVROLET | UNIVERSAL | OIL FILLER CAP<br>UNIVERSAL SCREW-IN          | 36-18710002, 38-18710                    |
| EQ-PCV350 | CHEVROLET | UNIVERSAL | ROCKER COVER /<br>BREATHER GROMMET, UNIVERSAL | 23-8M0071559                             |



## MARINE COMPONENTS

### TIMING COVERS

| PART #    | ENG MFG   | CID  | LITERS | YEARS       | NOTES                                                                                                       | MERCUISER / QUICK SILVER CROSS REFERENCE |
|-----------|-----------|------|--------|-------------|-------------------------------------------------------------------------------------------------------------|------------------------------------------|
| EQ-TC181N | CHEVROLET | 153  | 2.5    | ALL         |                                                                                                             | 5934141A1, 49951                         |
| EQ-TC181N | CHEVROLET | 181  | 3.0    | 1963 - 1989 |                                                                                                             | 5934141A1, 49951                         |
| EQ-TC350M | CHEVROLET | 262  | 4.3    | 1986 - 1995 | METAL - 6-3/4" BALANCER TIMING MARK AT 2 O'CLOCK<br>NON-BALANCE SHAFT ENGINE                                | 14249A2, 60660A1                         |
| EQ-TC262P | CHEVROLET | 262  | 4.3    | 1996 - 2003 | PLASTIC<br>NON-BALANCE SHAFT ENGINE<br>INCLUDES PLUG KIT TO BLOCK CRANK POSITION SENSOR HOLE IN COVER       | 809893, 863396                           |
| EQ-TC351A | FORD      | 302  | 5.0    | 1970 - 1974 | ALUMINUM                                                                                                    | 56103                                    |
| EQ-TC350M | CHEVROLET | 305  | 5.0    | 1986 - 1995 | METAL - 6-3/4" BALANCER TIMING MARK AT 2 O'CLOCK                                                            | 14249A2, 60660A1                         |
| EQ-TCC349 | CHEVROLET | 305  | 5.0    | 1986 - 1995 | METAL - NO TIMING MARK<br>FOR USE WITH 8" O.D. BALANCER<br>ORDER <a href="#">EQ-TM350</a> MARKER SEPARATELY |                                          |
| EQ-TC350P | CHEVROLET | 305  | 5.0    | 1996 - 2002 | PLASTIC<br>INCLUDES PLUG KIT TO BLOCK CRANK POSITION SENSOR HOLE IN COVER                                   | 835005                                   |
| EQ-TC318N | CHRYSLER  | 318  | 5.2    | 1975 - 1985 | ALUMINUM, LM318 / LM360                                                                                     | 3619878, 4142252                         |
| EQ-TC350P | CHEVROLET | 350  | 5.7    | 1996 - 2003 | PLASTIC<br>INCLUDES PLUG KIT TO BLOCK CRANK POSITION SENSOR HOLE IN COVER                                   | 835005                                   |
| EQ-TC350M | CHEVROLET | 350  | 5.7    | 1986 - 1995 | METAL - 6-3/4" BALANCER TIMING MARK AT 2 O'CLOCK                                                            | 14249A2, 60660A1                         |
| EQ-TCC349 | CHEVROLET | 350  | 5.7    | 1986 - 1995 | METAL - NO TIMING MARK<br>FOR USE WITH 8" O.D. BALANCER<br>ORDER <a href="#">EQ-TM350</a> MARKER SEPARATELY |                                          |
| EQ-TC351A | FORD      | 351W | 5.8    | 1973 - 1977 | ALUMINUM                                                                                                    | 56103                                    |
| EQ-TC318N | CHRYSLER  | 360  | 5.9    | 1975 - 1985 | ALUMINUM, LM318 / LM360                                                                                     | 3619878, 4142252                         |
| EQ-TCC454 | CHEVROLET | 427  | 7.0    | 1969 - 1974 | METAL                                                                                                       | 66215                                    |
| EQ-TCC454 | CHEVROLET | 454  | 7.4    | 1968 - 1990 | METAL                                                                                                       | 66215                                    |
| EQ-TC460N | FORD      | 460  | 7.5    | 1968 - 1997 | ALUMINUM                                                                                                    |                                          |

### WINDAGE TRAY/OIL BAFFLE

| PART #     | ENG MFG   | CID | LITERS | YEARS       | NOTES                                          | MERCUISER / QUICK SILVER CROSS REFERENCE |
|------------|-----------|-----|--------|-------------|------------------------------------------------|------------------------------------------|
| EQ-WTC350N | CHEVROLET | 305 | 5.0    | 1979 - 1997 | WINDAGE TRAY / OIL BAFFLE                      | 98602, 986021                            |
| EQ-WTC350N | CHEVROLET | 350 | 5.7    | 1979 - 1997 | WINDAGE TRAY / OIL BAFFLE                      | 98602, 986021                            |
| EQ-SBM350  | CHEVROLET | 262 | 4.3    | 1986 - 1993 | STUDDER MAIN BOLT / WINDAGE TRAY MOUNTING BOLT | 16-54790                                 |
| EQ-SBM350  | CHEVROLET | 305 | 5.0    | 1979 - 1997 | STUDDER MAIN BOLT / WINDAGE TRAY MOUNTING BOLT | 16-54790                                 |
| EQ-SBM350  | CHEVROLET | 350 | 5.7    | 1979 - 1997 | STUDDER MAIN BOLT / WINDAGE TRAY MOUNTING BOLT | 16-54790                                 |



# THE NAME YOU TRUST FOR ENGINE PARTS

## MARINE COMPONENTS

### OIL FILTER ADAPTORS

| PART #    | ENG MFG   | CID  | LITERS | YEARS        | NOTES                        | MERCUISER / QUICK SILVER CROSS REFERENCE |
|-----------|-----------|------|--------|--------------|------------------------------|------------------------------------------|
| EQ-OFA454 | CHEVROLET | 181  | 3.0    |              | L4 – ALSO KNOWN AS CONNECTOR | 22-805632                                |
| EQ-OFA262 | CHEVROLET | 262  | 4.3    | 1986 - 1993  | V6 - ALSO KNOWN AS CONNECTOR | 11972                                    |
| EQ-OFA305 | CHEVROLET | 305  | 5.0    | 1986 - 2002  | V8 - ALSO KNOWN AS CONNECTOR | 71920                                    |
| EQ-OFA305 | CHEVROLET | 350  | 5.7    | 1986 - 2002  | V8 - ALSO KNOWN AS CONNECTOR | 71920                                    |
| EQ-OFA454 | CHEVROLET | 454  | 7.4    | 1965 & NEWER | V8 - ALSO KNOWN AS CONNECTOR | 22-805632                                |
| EQ-OFA454 | CHEVROLET | 502  | 8.2    | 1996 & NEWER | V8 - ALSO KNOWN AS CONNECTOR | 22-805632                                |
| EQ-OFA302 | FORD      | 302  | 5.0    | 1970 - 1990  | V8 - ALSO KNOWN AS CONNECTOR | 22-56876                                 |
| EQ-OFA302 | FORD      | 351W | 5.8    | 1970 - 1994  | V8 - ALSO KNOWN AS CONNECTOR | 22-56877                                 |
| EQ-OFA460 | FORD      | 460  | 7.5    | 1968 - 1997  | V8 - ALSO KNOWN AS CONNECTOR |                                          |

### OIL PANS

| PART #    | ENG MFG   | CID | LITERS | YEARS       | NOTES                                                                                         | MERCUISER / QUICK SILVER CROSS REFERENCE |
|-----------|-----------|-----|--------|-------------|-----------------------------------------------------------------------------------------------|------------------------------------------|
| EQ-OP262M | CHEVROLET | 262 | 4.3    | 1986 - 1993 | FOR USE ON 1 PIECE REAR SEAL ENGINE                                                           | 14244                                    |
| EQ-OP350M | CHEVROLET | 305 | 5.0    | 1986 - 1996 | FOR USE ON 1 PIECE REAR SEAL ENGINE<br>5 QUART. FOR USE WITH BOLT-IN<br>WINDAGE TRAY / BAFFLE | 13840A1, 805930A1                        |
| EQ-OP350N | CHEVROLET | 305 | 5.0    | 1989 - UP   | 12MM DRAIN PLUG<br>FOR USE WITH BOLT-IN<br>WINDAGE TRAY / BAFFLE                              | 808588, 809910, 88901T                   |
| EQ-OP350M | CHEVROLET | 350 | 5.7    | 1986 - 1996 | 5 QUART. FOR USE WITH BOLT-IN<br>WINDAGE TRAY / BAFFLE                                        | 3840A1, 805930A1                         |
| EQ-OP350N | CHEVROLET | 350 | 5.7    | 1989 - UP   | 12MM DRAIN PLUG<br>FOR USE WITH BOLT-IN<br>WINDAGE TRAY / BAFFLE                              | 808588, 889501T, 809910                  |
| EQ-OP454  | CHEVROLET | 427 | 7.0    | 1969 - 1974 | 2 REAR SEAL ENGINE APPLICATION                                                                | 47552A5, 47552                           |
| EQ-OP454  | CHEVROLET | 454 | 7.4    | 1965 - 1990 | 2 REAR SEAL ENGINE APPLICATION                                                                | 47552A5, 47552                           |

### OIL PAN RAILS

| PART #    | ENG MFG   | CID | LITERS | YEARS       | NOTES                                                                    | MERCUISER / QUICK SILVER CROSS REFERENCE    |
|-----------|-----------|-----|--------|-------------|--------------------------------------------------------------------------|---------------------------------------------|
| EQ-OPR262 | CHEVROLET | 262 | 4.3    | 1986 - 1993 | FOR USE ON 1 PIECE REAR SEAL ENGINE<br>AND WITH OIL PAN PART # EQ-OP262M | 14245 (RIGHT SIDE)<br>14246 (LEFT SIDE)     |
| EQ-OPR350 | CHEVROLET | 305 | 5.0    | 1985 - 2002 | FOR USE ON 1 PIECE REAR SEAL ENGINE                                      | 14257 (PORT SIDE)<br>14256 (STARBOARD SIDE) |
| EQ-OPR350 | CHEVROLET | 350 | 5.7    | 1985 - 2002 | FOR USE ON 1 PIECE REAR SEAL ENGINE                                      | 14257 (PORT SIDE)<br>14256 (STARBOARD SIDE) |



## MARINE COMPONENTS

### CYLINDER HEADS

| PART #      | ENG MFG   | CID | LITERS | YEARS       | NOTES                                                                                                                                                                                                  | MERCUISER / QUICK SILVER<br>CROSS REFERENCE |
|-------------|-----------|-----|--------|-------------|--------------------------------------------------------------------------------------------------------------------------------------------------------------------------------------------------------|---------------------------------------------|
| EQ-CH181M   | CHEVROLET | 181 | 3.0    |             | REPLACES CASTING # 14096620                                                                                                                                                                            | 936-81840, 936-8M0115135                    |
| EQ-CH181MA  | CHEVROLET | 181 | 3.0    |             | REPLACES CASTING # 14096620<br><b>ASSEMBLED</b>                                                                                                                                                        | 936-81840, 936-8M0115135                    |
| EQ-GP181M*  | CHEVROLET | 181 | 3.0    |             | SET OF 4 GUIDE PLATES<br>(EQ-SIS350 SCREW IN STUDS SOLD SEPARATELY)                                                                                                                                    |                                             |
| EQ-CH262NO  | CHEVROLET | 262 | 4.3    | 1992 - 2014 | VORTEC DESIGN 8 BOLT INTAKE<br>REPLACES CASTING # 12557113                                                                                                                                             |                                             |
| EQ-CH262NOA | CHEVROLET | 262 | 4.3    | 1992 - 2014 | VORTEC DESIGN 8 BOLT INTAKE<br>REPLACES CASTING # 12557113<br><b>ASSEMBLED</b>                                                                                                                         |                                             |
| EQ-CH262NC  | CHEVROLET | 262 | 4.3    | 1992 - 2014 | VORTEC DESIGN 8 BOLT INTAKE<br>REPLACES CASTING # 12557113<br><b>AFTERMARKET REPLACEMENT</b>                                                                                                           |                                             |
| EQ-CH305B   | CHEVROLET | 305 | 5.0    | 1996 - UP   | REPLACES CASTING NUMBER:<br>12552520, 12557113, 12558059<br>INTAKE RUNNER 170CC,<br>COMBUSTION CHAMBER 58CC                                                                                            | 938-802556                                  |
| EQ-CH305BA  | CHEVROLET | 305 | 5.0    | 1996 - UP   | REPLACES CASTING NUMBER:<br>12552520, 12557113, 12558059<br>INTAKE RUNNER 170CC,<br>COMBUSTION CHAMBER 58CC<br><b>ASSEMBLED</b>                                                                        | 938-802556                                  |
| EQ-CH350A   | CHEVROLET | 350 | 5.7    | 1969 - 1986 | UNIVERSAL / INTAKE RUNNER 178CC<br>COMBUSTION CHAMBER 76CC<br>WITH HEAT RISER<br>69-86 INTAKE MANIFOLD BOLT PATTERN<br>7 BOLT HOLE EXHAUST MOUNTING<br>PERIMETER VALVE COVER HOLES                     | 938-7499                                    |
| EQ-CH350AA  | CHEVROLET | 350 | 5.7    | 1969 - 1986 | UNIVERSAL / INTAKE RUNNER 178CC<br>COMBUSTION CHAMBER 76CC<br>WITH HEAT RISER<br>69-86 INTAKE MANIFOLD BOLT PATTERN<br>7 BOLT HOLE EXHAUST MOUNTING<br>PERIMETER VALVE COVER HOLES<br><b>ASSEMBLED</b> | 938-7499                                    |
| EQ-CH350G   | CHEVROLET | 350 | 5.7    | 1987-1995   | REPLACES CASTING NUMBER:<br>083, 191, 193, 217, 810,<br>WITH HEAT RISER<br>87-95 INTAKE MANIFOLD BOLT PATTERN<br>CENTER BOLT DOWN VALVE COVER HOLES<br>RECOMMENDED TO BE REPLACED IN PAIRS             | 938-883490 1                                |

CYLINDER HEADS CONTINUED ON PAGE 35

# THE NAME YOU TRUST FOR ENGINE PARTS

## MARINE COMPONENTS

### CYLINDER HEADS (continued)

| PART #     | ENG MFG   | CID | LITERS | YEARS                    | NOTES                                                                                                                                                                                                                                                                                                                   | MERCUISER / QUICK SILVER CROSS REFERENCE |
|------------|-----------|-----|--------|--------------------------|-------------------------------------------------------------------------------------------------------------------------------------------------------------------------------------------------------------------------------------------------------------------------------------------------------------------------|------------------------------------------|
| EQ-CH350GA | CHEVROLET | 350 | 5.7    | 1987-1995                | REPLACES CASTING NUMBER:<br>083, 191, 193, 217, 810,<br>WITH HEAT RISER<br>87-95 INTAKE MANIFOLD BOLT PATTERN<br>CENTER BOLT DOWN VALVE COVER HOLES<br>RECOMMENDED TO BE REPLACED IN PAIRS<br><b>ASSEMBLED</b>                                                                                                          | 938-883490 1                             |
| EQ-CH350C  | CHEVROLET | 350 | 5.7    | 1996-2006                | REPLACES CASTING NUMBERS:<br>12558062, 10239906<br>INTAKE RUNNER 170CC<br>COMBUSTION CHAMBER 64CC                                                                                                                                                                                                                       | 938-883297, 938-803860T                  |
| EQ-CH350CA | CHEVROLET | 350 | 5.7    | 1996-2006                | REPLACES CASTING NUMBERS:<br>12558062, 10239906<br>INTAKE RUNNER 170CC<br>COMBUSTION CHAMBER 64CC<br><b>ASSEMBLED</b>                                                                                                                                                                                                   | 938-883297, 938-803860T                  |
| EQ-CH454C  | CHEVROLET | 454 | 7.4    | 1996 - 2000<br>UNIVERSAL | REPLACES CASTING NUMBERS:<br>12560241, 10141279<br>246CC INTAKE RUNNER<br>100CC COMBUSTION CHAMBER<br>VORTEC CHAMBER (.370/.3716 VALVE ID)<br>DIRECT REPLACEMENT FOR 1996- 2000 /<br>WHEN INSTALLING ON 1996 AND EARLIER<br>MODELS, MUST USE BOLT DOWN ROCKER<br>ARMS AND HEAD GASKET BY FELPRO<br># 1017 OR EQUIVALENT | 938-883492R1                             |
| EQ-CH454CA | CHEVROLET | 454 | 7.4    | 1996 - 2000              | REPLACES CASTING NUMBERS:<br>12560241, 10141279<br>246CC INTAKE RUNNER<br>100CC COMBUSTION CHAMBER<br>VORTEC CHAMBER (.370/.3716 VALVE ID)<br><b>ASSEMBLED</b>                                                                                                                                                          | 938-883492R1                             |

\*EQ-GP181M\* USE GUIDE PLATES WITH THE FOLLOWING CYLINDER HEAD PART NUMBERS:

EQ-CH181M / EQ-CH181MA  
EQ-CH305B / EQ-CH305BA  
EQ-CH350C / EQ-CH350CA

EQ-CH350G / EQ-CH350GA  
EQ-CH350A / EQ-CH350AA



EQ-SIS350

### SCREW IN STUDS

**Small Block Chevrolet & 3.0L 181 4-Cylinder Marine Industrial**

**Each Cylinder Head Requires The Use Of A Screw-In Rocker Arm Stud**

PART# EQ-SIS350 (8 pcs. per set, enough for 1 cylinder head)

- STUDS MEASURE 7/16-14 X 3/8-24 X 2.375" OVERALL
- HEAT TREATED TO RC 33-39 AND ARE OXIDE

## MARINE COMPONENTS

### HEAD BOLTS

| PART #    | ENG MFG   | CID | LITERS | YEARS       | NOTES              | MERCUISER / QUICK SILVER CROSS REFERENCE                                         |
|-----------|-----------|-----|--------|-------------|--------------------|----------------------------------------------------------------------------------|
| EQ-HB262N | CHEVROLET | 262 | 4.3    | 1985 - 1997 | 5/8" HEX HEAD BOLT |                                                                                  |
| EQ-HB263N | CHEVROLET | 262 | 4.3    | 1997 - 2006 | 1/2" HEX HEAD      | 10-11966, 10-119671, 10-11968                                                    |
| EQ-HB350P | CHEVROLET | 305 | 5.0    | 1969 - 1997 | 1/2" HEX HEAD      | 10-11966, 10-119671, 10-11968                                                    |
| EQ-HB350P | CHEVROLET | 350 | 5.7    | 1969 - 1997 | 1/2" HEX HEAD      | 10-11966, 10-119671, 10-11968                                                    |
| EQ-HB350N | CHEVROLET | 305 | 5.0    | 1969 - 1997 | 5/8" HEX HEAD BOLT |                                                                                  |
| EQ-HB350N | CHEVROLET | 350 | 5.7    | 1969 - 1997 | 5/8" HEX HEAD BOLT |                                                                                  |
| EQ-HB454N | CHEVROLET | 427 | 7.0    | 1969 - 1974 | BIG BLOCK          | 10-8M0000463, 10-8M0000482                                                       |
| EQ-HB454N | CHEVROLET | 454 | 7.4    | 1965 - 1990 | BIG BLOCK          | 10-8M0000463, 10-8M0000482                                                       |
| EQ-HB496N | CHEVROLET | 496 | 8.1    | 2001 - 2006 |                    | 10-881642A01 - 10-881625<br>10-881642A01 - 10-881624<br>10-881642A01 - 10-881642 |
| EQ-HB454N | CHEVROLET | 502 | 8.2    | 1990 - 1998 |                    | 10-8M0000463, 10-8M0000482                                                       |
| EQ-HB302N | FORD      | 302 | 5.0    | 1970 - 2001 |                    | 10-56112, 10-56113                                                               |
| EQ-HB370N | FORD      | 460 | 7.5    | 1968 - 1997 |                    |                                                                                  |

### HARMONIC BALANCER & REPLACEMENT SLEEVE

| PART #    | ENG MFG | CID | LITERS   | YEARS       | NOTES                       |
|-----------|---------|-----|----------|-------------|-----------------------------|
| EQ-BA460A | FORD    | 460 | 7.0, 7.5 | 1968 - 1997 |                             |
| EQ-SLF460 | FORD    | 460 | 7.0, 7.5 | 1968 - 1997 | INTERNALLY BALANCED ENGINES |

EQ-BA460A



EQ-SLF460



### SIDE COVER - PUSH ROD

| PART #    | ENG MFG   | CID | LITERS | YEARS | MERCUISER / QUICK SILVER CROSS REFERENCE |
|-----------|-----------|-----|--------|-------|------------------------------------------|
| EQ-SP181N | CHEVROLET | 153 | 2.5    | ALL   | 39332A1                                  |
| EQ-SP181N | CHEVROLET | 181 | 3.0    | ALL   | 39332A1                                  |

EQ-SP181N



### INTAKE MANIFOLD PLUG KIT

All The Pipe Plugs Needed To Block The Threaded Holes  
In EQ-IN350MA & EQ-IN350MB

| PART #     | MFG       | CID | LITER | YEARS | ITEM          |
|------------|-----------|-----|-------|-------|---------------|
| EQ-PKIN350 | CHEVROLET | 350 | 5.7   | ALL   | PIPE PLUG KIT |

EQ-PKIN350



# THE NAME YOU TRUST FOR ENGINE PARTS

## MARINE COMPONENTS

### INTAKE MANIFOLD



- 4 Barrel Universal Carburetor mounting
- 15 degree carb flange
- All required mounting & accessories holes are tapped
- Superior runner finish for increased air flow
- CNC machined for exact fit & bolt hole location
- Manufactured of the highest grade of cast iron to resist salt water corrosion that aluminum intakes experience & corrosion caused by Natural gas and other dry fuels
- Electric Choke

| PART #     | ENG MFG   | CID | LITERS | YEARS       | MERCUISER / QUICK SILVER CROSS REFERENCE |
|------------|-----------|-----|--------|-------------|------------------------------------------|
| EQ-IN350MB | CHEVROLET | 305 | 5.0    | 1987 - 1995 |                                          |
| EQ-IN350MA | CHEVROLET | 305 | 5.0    | 1996 - 2002 | 17618T                                   |
| EQ-IN350MB | CHEVROLET | 350 | 5.7    | 1987 - 1995 |                                          |
| EQ-IN350MA | CHEVROLET | 350 | 5.7    | 1996 - 2002 | 17618T                                   |

### ROLLER LIFTER GUIDES & RETAINERS

EQ-RLG350



EQ-RLG454



EQ-RLR350N



| PART #       | ENG MFG   | CID | LITERS | YEARS       | NOTES                                                                                             | MERCUISER / QUICK SILVER CROSS REFERENCE |
|--------------|-----------|-----|--------|-------------|---------------------------------------------------------------------------------------------------|------------------------------------------|
| EQ-RLG350    | CHEVROLET | 305 | 5.0    | 1986 - UP   | ALSO KNOWN AS CLIPS                                                                               | 17341T                                   |
| EQ-RLG350    | CHEVROLET | 350 | 5.7    | 1986 - UP   | ALSO KNOWN AS CLIPS                                                                               | 17341T                                   |
| EQ-RLG454    | CHEVROLET | 454 | 7.4    | 1986 - UP   | ALSO KNOWN AS CLIPS                                                                               | 845754, 850474                           |
| EQ-RLR350N   | CHEVROLET | 305 | 5.0    | 1986 - 1997 | ALSO KNOWN AS SPIDER                                                                              | 811662                                   |
| EQ-RLR350N   | CHEVROLET | 350 | 5.7    | 1986 - 1997 | ALSO KNOWN AS SPIDER                                                                              | 811662                                   |
| EQ-RLR350KIT | CHEVROLET | 305 | 5.0    | 1986 - 1997 | RETAINER, 3 MOUNTING BOLTS, 8 CLIPS                                                               | 811662, 17341T                           |
| EQ-RLR350KIT | CHEVROLET | 350 | 5.7    | 1986 - 1997 | RETAINER, 3 MOUNTING BOLTS, 8 CLIPS                                                               | 811662, 17341T                           |
| EQ-RLRDLXA   | CHEVROLET | 305 | 5.0    | 1986 - 1990 | RETAINER, 3 MOUNTING BOLTS, 8 CLIPS, CAM THRUST PLATE (4.23" T2T)<br>CAM PLATE MOUNTING BOLTS (2) |                                          |
| EQ-RLRDLXA   | CHEVROLET | 350 | 5.7    | 1986 - 1990 | RETAINER, 3 MOUNTING BOLTS, 8 CLIPS, CAM THRUST PLATE (4.23" T2T)<br>CAM PLATE MOUNTING BOLTS (2) |                                          |
| EQ-RLRDLXB   | CHEVROLET | 305 | 5.0    | 1991 - 2002 | RETAINER, 3 MOUNTING BOLTS, 8 CLIPS, CAM THRUST PLATE (3.90" T2T)<br>CAM PLATE MOUNTING BOLTS (2) |                                          |
| EQ-RLRDLXB   | CHEVROLET | 350 | 5.7    | 1991 - 2002 | RETAINER, 3 MOUNTING BOLTS, 8 CLIPS, CAM THRUST PLATE (3.90" T2T)<br>CAM PLATE MOUNTING BOLTS (2) |                                          |

### BLOCK OFF PLATES WITH GASKETS / FUEL PUMP

EQ-BOP076



EQ-BOP087



| PART #    | ENG MFG   | CID        | LITER      | NOTES           | CROSS REFERENCE MERCUISER / QUICK SILVER |
|-----------|-----------|------------|------------|-----------------|------------------------------------------|
| EQ-BOP076 | UNIVERSAL |            |            | 2 HOLE MOUNTING |                                          |
| EQ-BOP087 | CHEVROLET | 305<br>350 | 5.0<br>5.7 | 4 HOLE MOUNTING | 807695, 809695T                          |



## OEM INTERCHANGE

| PART #   | INTERCHANGE    | OTHER       |
|----------|----------------|-------------|
| BA289N   | C5AZ6312A      | FORD        |
| BA390N   | C8AZ6316B      | FORD        |
| BA390N   | D5TE6316       | FORD        |
| BA460N   | D9TE6313FA     | FORD        |
| BA460N   | D9TZ6316C      | FORD        |
| BDV8F    | EAD6397A / B   | FORD        |
| BDV8F    | FA1AZ6890B     | FORD        |
| BOPO87   | 807695         | MERCURUISER |
| BP085N   | 12602540       | GM          |
| CB243N   | 83502890       | CHRYSLER    |
| CB243N   | J3243155       | JEEP        |
| CE120I   | E80Z6287A      | FORD        |
| CE1200   | D0AZ6287A      | FORD        |
| CE121N   | D5AZ6287A      | FORD        |
| CE129N   | 13515-37900    | TOYOTA      |
| CE129N   | 13517-37010    | TOYOTA      |
| CE129N   | 13571-35010    | TOYOTA      |
| CH122AA  | F2Y110100      | HYSTER      |
| CH122AA  | HY-1360878     | HYSTER      |
| CH124NA  | MD192297       | CHRYSLER    |
| CH134N   | 12360424       | GM          |
| CH136NA  | 11101-71010    | TOYOTA      |
| CH136NA  | 11101-71030    | TOYOTA      |
| CH136NA  | 11101-73020    | TOYOTA      |
| CH136NA  | 11101-76075-71 | TOYOTA      |
| CH140A   | F57E           | FORD        |
| CH140A   | F5JL           | FORD        |
| CH140A   | F77Z6049AA     | FORD        |
| CH140A   | F87E           | FORD        |
| CH140A   | F87Z6049AARM   | FORD        |
| CH140A   | ZZR010100ROA   | MAZDA       |
| CH143AA  | 800124641      | YALE        |
| CH144N   | 11101-35060    | TOYOTA      |
| CH146A   | GWE-20002578   | NISSAN      |
| CH146E   | 12608280       | GM          |
| CH150N   | 117            | JEEP        |
| CH150N   | 2403           | JEEP        |
| CH152NA  | 11040-FY501    | NISSAN      |
| CH154NA  | MD026520       | CHRYSLER    |
| CH154NA  | MD151968       | CHRYSLER    |
| CH181M   | 10140599       | GM          |
| CH181ND  | 53020983       | CHRYSLER    |
| CH181NP  | 53020983       | JEEP        |
| CH226LN  | 53020983       | CHRYSLER    |
| CH226LN  | 53020983       | JEEP        |
| CH226LN  | 53020983AB     | CHRYSLER    |
| CH226LN  | 53020983AB     | JEEP        |
| CH226RN  | 53020984       | CHRYSLER    |
| CH226RN  | 53020984AB     | JEEP        |
| CH226RN  | 53020984AB     | CHRYSLER    |
| CH226RN  | 53020984AB     | JEEP        |
| CH242N   | 0331           | JEEP        |
| CH242NA  | 0331           | JEEP        |
| CH244C   | 98TM           | FORD        |
| CH226NOA | 53020803       | CHRYSLER    |

| PART #   | INTERCHANGE  | OTHER       |
|----------|--------------|-------------|
| CH262NOA | 53020803     | JEEP        |
| CH281LN  | 53020801AC   | CHRYSLER    |
| CH281LN  | 53020801AC   | JEEP        |
| CH281LN  | 53020803     | CHRYSLER    |
| CH281LN  | 53020803     | JEEP        |
| CH281RN  | 53020804     | CHRYSLER    |
| CH281RN  | 53020804     | JEEP        |
| CH281RN  | 53020802     | CHRYSLER    |
| CH281RN  | 53020802     | JEEP        |
| CH300AA  | 5306671      | CHRYSLER    |
| CH318A   | 5302044      | CHRYSLER    |
| CH318A   | 5306671      | CHRYSLER    |
| CH318A   | 5306466      | CHRYSLER    |
| CH330ND  | RF9L3E       | FORD        |
| CH330NP  | RF9L3E       | FORD        |
| CH350A   | ...624       | GM          |
| CH350C   | ...062       | GM          |
| CH350C   | ...906       | GM          |
| CH350C   | 938-883297   | MERCURUISER |
| CH350CA  | 10239906     | GM          |
| CH350CA  | 12528913     | GM          |
| CH350CA  | 12558062     | GM          |
| CH350CA  | 12529509     | GM          |
| CH350CA  | 938-803860T  | MERCURUISER |
| CH364A   | 12564825     | GM          |
| CH364B   | 12629049     | GM          |
| CH364B   | 243          | GM          |
| CH364B   | 799          | GM          |
| CH364C   | 12629063     | GM          |
| CH402A   | 97770597     | GM          |
| CH402B   | LBZ          | GM          |
| CH454C   | 938-883492R1 | MERCURUISER |
| CH454CA  | 938-883492R1 | MERCURUISER |
| CP300N   | C5AZ6269A    | FORD        |
| CP301N   | CP301N       | PONTIAC     |
| CP302N   | 1088128      | GM          |
| CP349N   | 10168501     | GM          |
| CP350N   | 10088128     | GM          |
| CP350N   | 10168501     | GM          |
| CP460N   | C8SZ-6754-A  | FORD        |
| CW302N   | C1TE6278A    | FORD        |
| DT460    | C8SZ-6754-A  | FORD        |
| EN1698   | F4TZ9430A    | FORD        |
| EN1699   | F4TZ9431A    | FORD        |
| FSP300N  | C5AZ6519B    | FORD        |
| FSP300N  | C5AZ6519C    | FORD        |
| FSP300N  | E5TZ6519B    | FORD        |
| FSP300N  | E7TZ6519A    | FORD        |
| FSP300N  | E7TZ6519A    | FORD        |
| FSP300N  | E5TZ6519B    | FORD        |
| FSP300N  | C5AZ6519C    | FORD        |
| FSP300N  | C5AZ6519B    | FORD        |
| FTP034   | 3514185      | FORD        |
| FTP034   | F4ZZ6E086A   | FORD        |
| GSK21N   | 10101-FY52K  | NISSAN      |

| PART #  | INTERCHANGE  | OTHER       |
|---------|--------------|-------------|
| GSK21N  | 11044-FU460  | NISSAN      |
| GSK21N  | 11044-FU400  | NISSAN      |
| GSK21N  | 11042-FY525  | NISSAN      |
| HB144N  | 90910-02058  | TOYOTA      |
| HB150A  | 6035514      | AMC         |
| HB150A  | 6035516      | AMC         |
| HB150B  | 6035514      | AMC         |
| HB150C  | 6035516      | AMC         |
| HB156A  | MD020730     | CHRYSLER    |
| HB171A  | D1FZ6435A    | FORD        |
| HB179A  | 90910-02075  | TOYOTA      |
| HB179N  | 90910-02075  | TOYOTA      |
| HB206A  | 90910-02077  |             |
| HB206N  | ES72168      | TOYOTA      |
| HB244N  | 6035514      | CHRYSLER    |
| HB244N  | 6035516      | CHRYSLER    |
| HB280A  | F1AZ6065A    | FORD        |
| HB280A  | F3AZ6065A    | FORD        |
| HB280A  | F5AZ6065A    | FORD        |
| HB302A  | F3ZZ6065B    | FORD        |
| HB302B  | F3ZZ6065C    | FORD        |
| HB302C  | F3ZZ6065D    | FORD        |
| HB302N  | F3ZZ6065B    | FORD        |
| HB302N  | F3ZZ6065C    | FORD        |
| HB302N  | F3ZZ6065D    | FORD        |
| HB318A  | 6034691      | CHRYSLER    |
| HB318B  | 6034960      | CHRYSLER    |
| HB349NA | 12558840     | GM          |
| HB349NA | 12560744     | GM          |
| HB349NA | 12560745     | GM          |
| HB349NB | 10168527     | GM          |
| HB349NC | 10168526     | GM          |
| HB350A  | 14082317     | GM          |
| HB350B  | 14082315     | GM          |
| HB350C  | 14082316     | GM          |
| HB350P  | 10168527     | GM          |
| HB350P  | 10168526     | GM          |
| HB350P  | 10168525     | GM          |
| HB350P  | 10-11966     | MERCURUISER |
| HB350P  | 10-119671    | MERCURUISER |
| HB350P  | 10-11968     | MERCURUISER |
| HB370A  | C8SZ6065A    | FORD        |
| HB370B  | C8SZ6065B    | FORD        |
| HB381A  | 14077193     | GM          |
| HB413N  | F5AZ6065A    | FORD        |
| HB454A  | 3877668      | GM          |
| HB454A  | 10141204     | GM          |
| HB454B  | 3877669      | GM          |
| HB454B  | 10141205     | GM          |
| HB454N  | 10-49105     | MERCURUISER |
| HB454N  | 10-49106     | MERCURUISER |
| HB454N  | 10-8M0000463 | MERCURUISER |
| HB454N  | 10-8M0000482 | MERCURUISER |
| HB496N  | 881642A01    | MERCURUISER |
| HD454   | 3894327      | GM          |

# THE NAME YOU TRUST FOR ENGINE PARTS

## OEM INTERCHANGE

| PART #  | INTERCHANGE | OTHER      |
|---------|-------------|------------|
| IN350MA | IN350MA     | MERCruISER |
| IN350MB | 17618T      | MERCruISER |
| JPP001  | 90345-51006 | TOYOTA     |
| JPP002  | 90344-52003 | TOYOTA     |
| JPP003  | 90344-53008 | TOYOTA     |
| JPP003  | 90344-53011 | TOYOTA     |
| OC350N  | 12551757    | GM         |
| OC350N  | 36-18710002 | MERCruISER |
| OC350N  | 38-18710    | MERCruISER |
| OFA244  | F0TZ6890A   | FORD       |
| OFA258  | J3173226    | CHRYSLER   |
| OFA262  | 14081300    | GM         |
| OFA262  | 11972       | MERCruISER |
| OFA294A | 12600225    | GM         |
| OFA294B | 12552357    | GM         |
| OFA302  | D7AZ6890A   | FORD       |
| OFA302  | 22-56876    | MERCruISER |
| OFA305  | 3952301     | GM         |
| OFA345  | 4104511A    | CHRYSLER   |
| OFA346  | 48923338AB  | CHRYSLER   |
| OFA454  | 3853870     | GM         |
| OFA454  | 22-805632   | MERCruISER |
| OFA460  | C9AE6890A   | FORD       |
| OGP294N | 12573460    | GM         |
| OGP294N | 12573460    | GM         |
| OP134N  | 24576441    | GM         |
| OP262M  | 14244       | MERCruISER |
| OP262M  | 10054809    | GM         |
| OP350E  | 465221      | GM         |
| OP350L  | 12528916    | GM         |
| OP350M  | 10242245    | GM         |
| OP350M  | 12529174    | GM         |
| OP350M  | 12559020    | GM         |
| OP350M  | 13840A1     | MERCruISER |
| OP350M  | 805930A1    | MERCruISER |
| OP350N  | 12518043    | GM         |
| OP350N  | 12559020    | GM         |
| OP350N  | 808588      | MERCruISER |
| OP350N  | 809910      | MERCruISER |
| OP400N  | 47552       | MERCruISER |
| OP454   | 47552A5     | MERCruISER |
| OP454   | 47552       | MERCruISER |
| OP454   | 14081027    | GM         |
| OP454   | 14091488    | GM         |
| OPR262  | 14246       | MERCruISER |
| OPR262  | 14246       | MERCruISER |
| OPR350  | 14256       | MERCruISER |
| OPR350  | 14257       | MERCruISER |
| OPR350  | 12553058    | GM         |
| OPR350  | 12553059    | GM         |
| OPR350  | 14088501    | GM         |
| OPR350  | 14088502    | GM         |
| RA360N  | E5TZ6A588A  | FORD       |
| RA360NA | E5TZ6A588A  | FORD       |
| RGB294N | 12551163    | GM         |

| PART #  | INTERCHANGE | OTHER       |
|---------|-------------|-------------|
| RGFO    | E5TZ6A588A  | FORD        |
| RLG350  | 12550002    | GM          |
| RLG350  | 14093634    | GM          |
| RLG350  | 17341T      | MERCruISER  |
| RLG454  | 845754      | MERCruISER  |
| RLG454  | 850474      | MERCruISER  |
| RLG454  | 12551397    | GM          |
| RLR294N | 12595365    | GM          |
| RLR350N | 811662      | MERCruISER  |
| RLR350N | 14101116    | GM          |
| SBM350  | 12561389    | GM          |
| SBM350  | 14091675    | GM          |
| SBM350  | 16 54790    | QUICKSILVER |
| SIS3350 | 16-801882   | MERCruISER  |
| SMB350  | 16-54790    | MERCruISER  |
| SP181N  | 93423830    | GM          |
| SP181N  | 39332A1     | MERCruISER  |
| SLF460  | D00Z-6359-A | FORD        |
| SLFE    | B8AZ-6359-A | FORD        |
| TC141I  | D4FZ6019C   | FORD        |
| TC141I  | E3ZZ6019B   | FORD        |
| TC142I  | F3ZZ6019B   | FORD        |
| TC173A  | 140100617   | GM          |
| TC173B  | 14090537    | GM          |
| TC173C  | 14024263    | GM          |
| TC173C  | 14024263    | GM          |
| TC173C  | 14033526    | GM          |
| TC173C  | 14048323    | GM          |
| TC181N  | 93423830    | MERCruISER  |
| TC181N  | 39332A1     | MERCruISER  |
| TC231J  | 68003438AC  | JEEP        |
| TC231RN | 25522651    | BUICK       |
| TC231RN | 25522651    | BUICK       |
| TC232DN | D9D6059BB   | FORD        |
| TC232DN | E7DE6059FA  | FORD        |
| TC232DN | F24E6059BA  | FORD        |
| TC232DN | E8DZ6603A   | FORD        |
| TC232EN | F65E6059AE  | FORD        |
| TC262P  | 12554555    | GM          |
| TC262P  | 12554557    | GM          |
| TC262P  | 863396      | MERCruISER  |
| TC300N  | E5TE6019H   | FORD        |
| TC318N  | 2951698     | CHRYSLER    |
| TC318N  | 3769966     | CHRYSLER    |
| TC350M  | 10243967    | GM          |
| TC350M  | 60660A1     | MERCruISER  |
| TC350M  | 14249A2     | MERCruISER  |
| TC350P  | 12558343    | GM          |
| TC350P  | 12562818    | GM          |
| TC350P  | 835005      | MERCruISER  |
| TC351A  | D40E6059    | FORD        |
| TC351A  | D7AE6059    | FORD        |
| TC351A  | D9TE6059    | FORD        |
| TC351A  | E7AZ6019A   | FORD        |
| TC351A  | 56103       | MERCruISER  |

| PART #  | INTERCHANGE | OTHER      |
|---------|-------------|------------|
| TC351C  | E0AE6059    | FORD       |
| TC351C  | E3AE6059    | FORD       |
| TC351C  | E6SZ6019B   | FORD       |
| TC351C  | E7PA6019A   | FORD       |
| TC351C  | F1SZ6019A   | FORD       |
| TC351E  | E5AE6059FA  | FORD       |
| TC351E  | E8AE6059    | FORD       |
| TC351E  | FOAZ6019A   | FORD       |
| TC351F  | E7TE6059AA  | FORD       |
| TC351F  | E7TZ6019A   | FORD       |
| TC351F  | F67Z6019AA  | FORD       |
| TC351F  | F6TE6059    | FORD       |
| TC351F  | F6TZ6019NA  | FORD       |
| TC351H  | F1SE6059BC  | FORD       |
| TC351H  | F67Z6019AA  | FORD       |
| TC351H  | F87E6059AA  | FORD       |
| TC454C  | 330850      | GM         |
| TC454C  | 3885048     | GM         |
| TC460C  | F6TZ6019MA  | FORD       |
| TC460N  | E5TZ6019K   | FORD       |
| TC460N  | E8TE6059    | FORD       |
| TCC305  | 12523974    | GM         |
| TCC305  | 12531283    | GM         |
| TCC349  | 10243967    | GM         |
| TCC350  | 10243963    | GM         |
| TCC454  | 66215       | MERCruISER |
| TM351A  | F1TZ6023A   | FORD       |
| TM454C  | 354407      | GM         |
| VC262   | 14244       | MERCruISER |
| VC262   | 14252       | MERCruISER |
| VC262   | 814504      | MERCruISER |
| VC262   | 10046193    | GM         |
| VC262   | 14091554    | GM         |
| VC300N  | C5AZ6582K   | FORD       |
| VC300N  | F1TZ6582C   | FORD       |
| VC350M  | 58211       | MERCruISER |
| VC350M  | 79961       | MERCruISER |
| VC350M  | 14095094    | GM         |
| VC350M  | 52331A1     | MERCruISER |
| VC350M  | 79961T1     | MERCruISER |
| VC352L  | 10211648    | GM         |
| VC352L  | 12555269    | GM         |
| VC352L  | 809995      | MERCruISER |
| WPH20   | 11060-50K00 | NISSAN     |
| WPH20   | 11060-50K00 | TCM        |
| WPH20   | 11060-50K00 | KOMATSU    |
| WTC350N | 982021      | MERCruISER |
| WTC350N | 12557231    | GM         |
| WTC350N | 3927136     | GM         |
| WTC350N | 3927136     | GM         |
| WTC403N | 126272246   | GM         |
| VC134N  | 12363166    | GM         |