

# Installation instructions

## 06 Mitsubishi Eclipse

### Set # 5.1113

**Note:** It is recommended that this set be professionally installed if you are unfamiliar with this type of work, and a factory service manual be purchased prior to performing any work on your vehicle for proper disassembly, reassembly and torque specs. These instructions are intended for bushing removal and install of Energy Suspension polyurethane bushings, once you have removed the factory component from your vehicle.



Press out factory shell and bushing in both positions.

Clean and de-burr the factory brackets prior to installing polyurethane.

The new urethane part should go in by hand or small amount of force by arbor press.

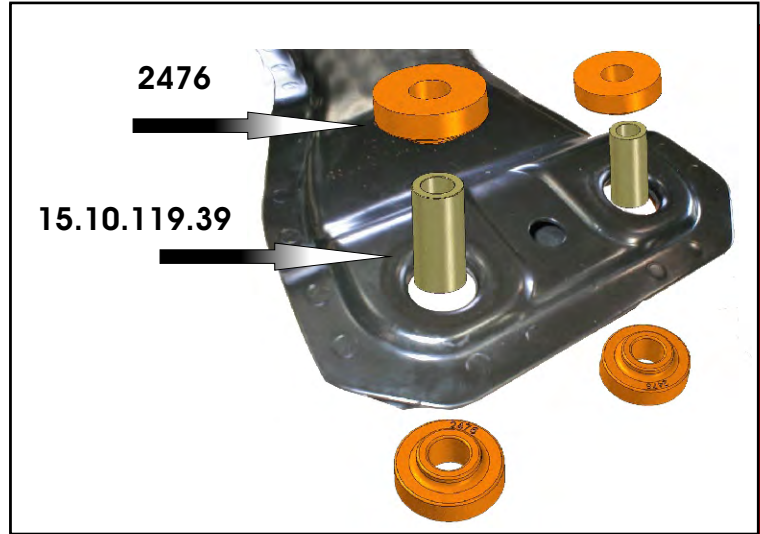

Press together Sleeves 15.10.462.39 and 15.10.463.39 to make the new sleeve for the rear position.

#### Sub frame:

Remove old bushings and sleeves. Clean and de-burr both positions. Install new 2476 bushings and 15.10.119.39 sleeves as shown in picture above.

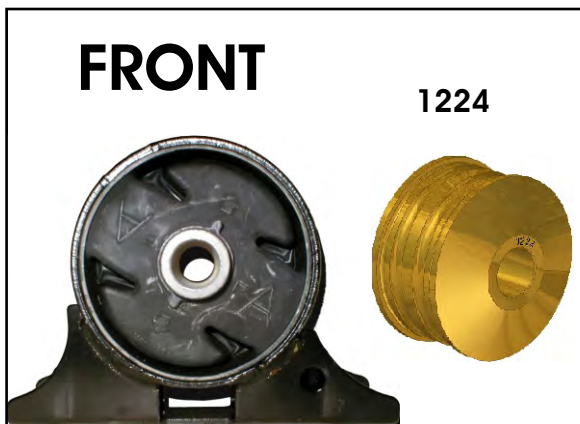

- 1 - 1224 Front position
- 1 - 15.10.565.39 Sleeve (1.000" x .563" x 2.435")
- 1 - 1144 Rear position
- 1 - 15.10.462.39 Sleeve (.750" x .625" x 2.425")
- 1 - 15.10.463.39 Sleeve (.625" x .437" x 2.425")
- 4 - 2476 Sub-frame bushings
- 2 - 15.10.119.39 Sleeve .687" x .500" x 1.300")
- 1 - 17476 Instruction sheet

17476