

# Installation Instructions for Set #5-1104

Read these instructions carefully before installing mounts.

1. Remove through bolt from front engine torque mount.
2. Remove 4 bolts from engine frame brace and remove.
3. Remove 2 bolts and take off front motor mount from engine frame brace.
4. Remove the 4 front engine frame base bushings and reinstall **NEW** Energy Suspension bushings. *Must reuse factory sleeves.* \*Clean sleeves before reusing.
5. Remove thru bolt from rear engine torque mount.
6. Remove 3 bolts and remove rear engine torque mount.
7. Using a press, remove the shell from each engine torque mount.
8. Press in the **NEW** Energy Suspension engine torque mounts.
9. Insert sleeves into **NEW** engine torque mounts.
10. Repeat steps in reverse order to reassemble.



## Rear Torque Mount Position

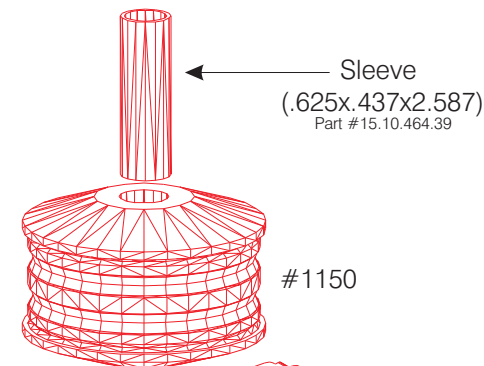

\*The #1150 rear bushing needs to be pressed in on the chamfer side of the metal motor mount. The mount has a smooth side and a chamfered side, pressing the bushing through non-chamfered side *could cause the bushing to tear.*

## Front Torque Mount Position

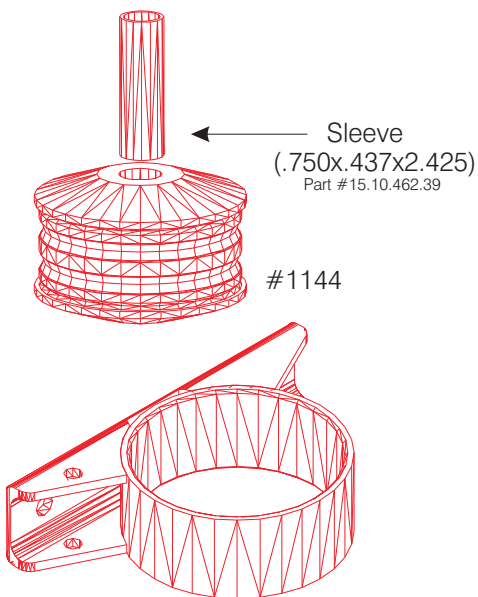

## Engine Frame Brace

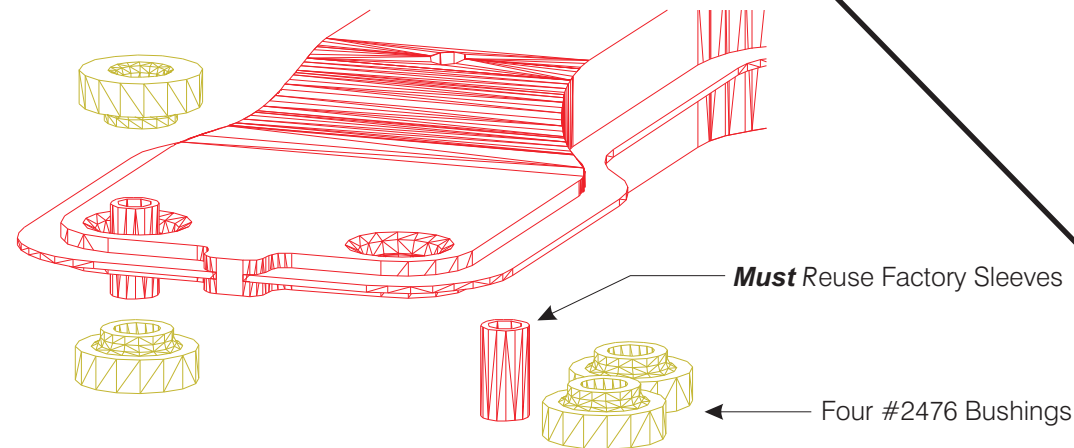

17348  
4-5-01  
NJ