

Instructions for GM style "clamshell" motor mount 4 - mounting holes Set # 3.1116

NOTE: Some applications use only three mounting bolts. Energy Suspension recommends replacing both left and right side mounts at the same time. Use a new lock nut at the engine bracket cross bolt location.



Raise vehicle to suitable height and support properly to allow easy access to the engine mounting locations. **NOTE: BE SURE VEHICLE IS SECURELY SUPPORTED BEFORE GOING UNDERNEATH.** Before loosening the motor mount bolts, find a suitable jacking location near the front of the engine block. Do not lift on crankshaft pulleys or oil pan. Severe damage could occur to these components. If available, use an engine hoist to raise engine. Raise the engine to a height necessary to remove load from the engine mounts. Remove the 5" long engine mounting bolts. Raise the engine again to allow enough clearance between the engine mounting brackets and motor mounts. **NOTE: BE CAREFUL NOT TO CAUSE DAMAGE TO OTHER ENGINE COMPONENTS BY RAISING THE ENGINE TOO HIGH, ie, DISTRIBUTOR CAP ON FIREWALL, FAN, etc.** Remove bolts securing motor mounts to front crossmember. It may be necessary to remove mounts, one side at a time. **NOTE: IT MAY BE NECESSARY TO USE A SPECIAL TOOL TO HOLD THE LOCK NUTS LOCATED INSIDE THE CROSSMEMBER.** Remove motor mounts from the crossmember and inspect the metal shells for damage. **NOTE: IT IS EXTREMELY IMPORTANT THAT THE METAL SHELLS BE UNDAMAGED.**

STEP - 1

Use a 3/8" drill bit to drill out rivets/welds. Drill down just enough to remove rivet material to allow the metal shells to be separated. After separation, remove any burrs or sharp edges from the drilled out holes. Be sure that the drilled holes have a diameter of at least 5/16".

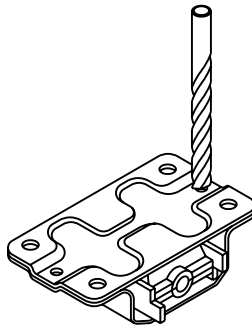

Clean any dirt and grease that may have accumulated inside the metal shells. **NOTE: IT IS VERY IMPORTANT THAT THE INSIDE OF THE METAL SHELLS BE CLEAN.** At this point, it is your option to have your metal painted, powder coated, or chromed.

When reassembling motor mounts, pay very close attention to the diagrams showing proper assembly procedure. This motor mount insert can go into the metal shells two ways; the right way, and the wrong way. Be sure to follow the instructions carefully so that you do it the right way!

STEP - 2

Push the polyurethane insert into the U-shaped metal shell, being sure that the large metal tabs (approx. 5/8" wide) protruding from the sides of the polyurethane insert, are nearest the side with the wide spaced holes in the metal shell. Align the bottom backing plate onto the polyurethane insert, making sure that all bolt holes line up.

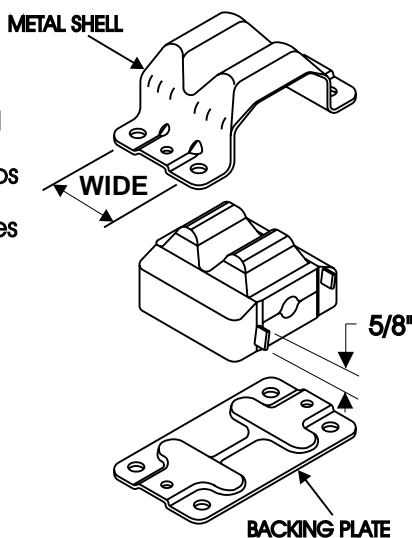

STEP - 3

Place the assembly into a vise or large clamp, leaving access to the drilled out holes. Use enough clamping force to hold the two metal shells together, without permanently deforming the metal (a slight amount of metal bending may occur, this is normal). To temporarily hold the assembly together, place the tie-wraps provided into the drilled holes, inserting them from the bottom side, leaving the locking end of the tie-wrap on the top side, as shown. Tighten the tie-wrap as tightly as possible, taking care not to break them.

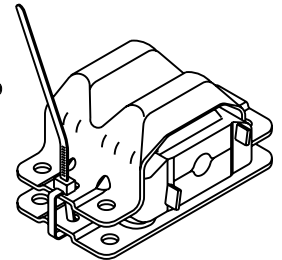

Make sure the tie-wraps are holding firm while releasing the clamp or vise. The metal shells may separate slightly, this is normal. However, excessive separation will cause the mounting bolts to not reach through the crossmember and allow the nuts to start on the bolts. Cut the ends of the tie-wraps off, being sure not to leave any sharp edges.

STEP - 4

Reassemble motor mounts into engine compartment, leaving all bolts loosened until the 5" long bolts going through the brackets have been successfully installed. Tighten all bolts to factory specifications. If so desired, you may remove the remaining portion of the tie-wraps.

NOTE: The ENERGY SUSPENSION Polyurethane motor mount insert will restore your engine to its original height. If adjustments have been made to other engine components, such as, fan shroud, fuel lines, etc. due to sagging, worn motor mounts, these components will need to be readjusted back to their original locations. **Also, be sure to check hood clearance before closing.**

HINT: Due to the many different metal configurations from foreign and domestic manufacturers it may be helpful to apply a thin coating of grease or dishwashing detergent to the polyurethane insert, at metal contact points before installing. This will allow the insert to seat, in turn allowing proper bolt alignment.

17250