

INSTALLATION INSTRUCTIONS

Rack and pinion bushing set # 8.10104
00-06 TOYOTA TUNDRA



17530

- 1.) Lock steering wheel to prevent it from rotating, before loosening any fasteners. Raise front of vehicle and support properly, allowing easy access to steering rack location.
- 2.) Remove rack attaching bolts, pull out rack just enough to remove rubber bushings.
- 3.) Install new bushings and sleeves as shown in diagram. Note: 1 3/4" flat washer must be installed between driver side rack bushing and vehicle crossmember.
- 4.) Position steering rack for installation, being sure not to damage bushings. Install "U" bracket over the "D" shaped bushing on passenger side rack mount. Begin tightening the fastener on the driver side location and the fasteners on the passenger side location until the sleeve in the center mount location aligns with the mounting holes in the crossmember.
- 5.) Install bolt in the center mount location. Install tie-rod end in the driver side steering knuckle.
- 6.) Tighten all fasteners to factory specifications.

VIEW FROM FRONT OF VEHICLE LOOKING REARWARD

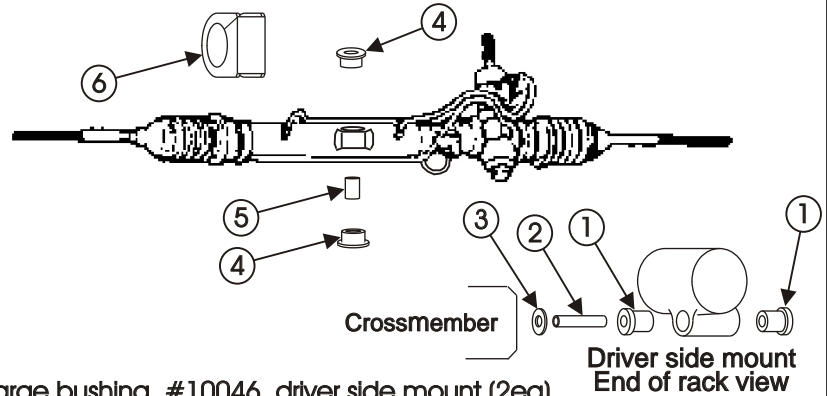

- 1 - Large bushing, #10046, driver side mount (2ea)
- 2 - Sleeve #15.10.610.39 (.875" O.D. x .635" I.D. x 2.887 Lg.)(1ea)
- 3 - Washer #15.03.21.39 (1.750" O.D. x .625" I.D. x .125" Thk.)(1ea)
- 4 - Small bushing, #10047, center mount position (2ea)
- 5 - Sleeve #15.10.611.39 (.875" O.D. x .688" I.D. x 1.560" Lg.)(1ea)
- 6 - "D" bushing, #10031, passenger side position (1ea)