

# Installation instructions

For set # 3.3194

Rear Control Arm Bushings

00-06 Suburban, Yukon XL, Tahoe, Denali XL  
02-06 Avalanche, Escalade 03-06 Hummer H2/H3



The original shells in the upper control arm, lower control arm and track arm must be reused. **DO NOT REMOVE THE SHELLS.** To remove old rubber bushings, apply light heat evenly around the outside of the outer metal shell, just enough to brake the bond with the rubber. When you see light smoke coming from the sides of the bushing the bond should be broken. At no time should there be any flames coming from the rubber, if there are any flames, you need to back off with the heat. Use caution when pushing the old rubber and inner metal sleeve out, they are preloaded and might eject quickly! Let the outer metal shell cool off before cleaning the inside.

The Thrust washers are designed to prevent the control arm from walking side to side by accepting side load pressure created upon hard cornering. Most kits contain more than one part #. It is very important to install them at the correct location. "SEE ILLUSTRATION # 1". NOTE: Thrust washers vary in sizes. Illustrations is only to show location and direction of installation (opposite of bushing flange). "SEE ILLUSTRATION # 2"

## ILLUSTRATION # 1

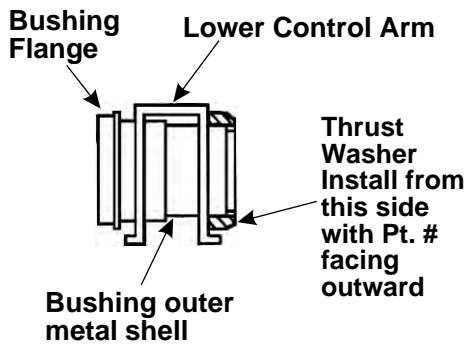

### UPPER CONTROL ARM AND TRACK ARM

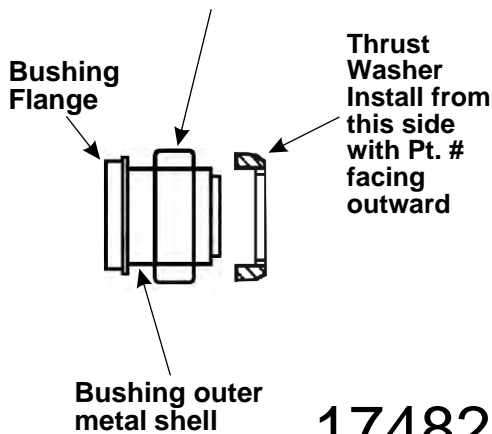

17482

## ILLUSTRATION # 2

### UPPER CONTROL ARM

3482  
Flange bushing  
15.10.83.39 Sleeve  
.875" X .563" X 2.030"

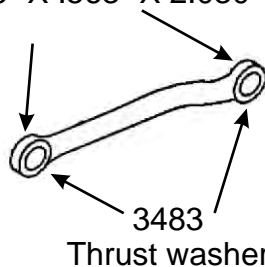

7124  
Flange bushing  
15.10.83.39 Sleeve  
.875" X .563" X 2.030"

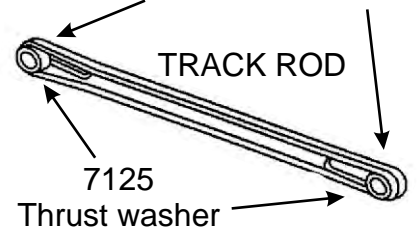

3480  
Flange bushing  
15.10.237.39 Sleeve  
.875" X .563" X 2.600"

