

Installation instructions

For set # 3.3189
AM GENERAL
HUMMER H1 / HMMWV

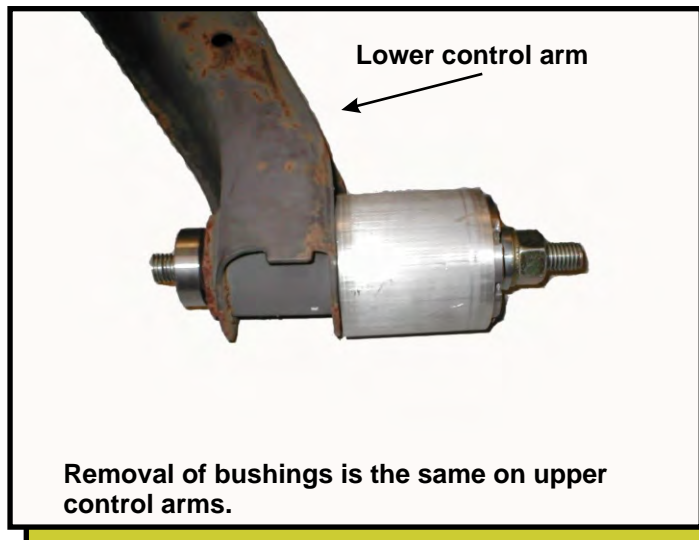

Note: To remove the old original bushings from control arms, a hydraulic press can be used to push the bushings out. If a hydraulic press is not available, use a piece of all-thread, tubing, flat washers and nuts. The inside minor diameter of all the control arms is 1.675". Use a thick washer with a 1.625" outside diameter on the inside of the control arm. The tubing needs to be big enough for the old bushing to fall into. The bushing only needs to move about 3/4" before it loses its press fit and falls out. Remove any sharp edges that might cut the new polyurethane bushings during installation. Apply grease to all metal parts that contact the polyurethane bushings.



Parts list for set # 3.3189.

- 8 - 2498 outer bushing with .230" flange cut.
- 8 - 2508 inner bushing with .230" flange cut.
- 8 - 15.10.123.39 sleeve 1.00" x .750" x 3.335".
- 8 - 9.11108 Formula 5 Prelube.
- 1 - 17435 installation instructions.

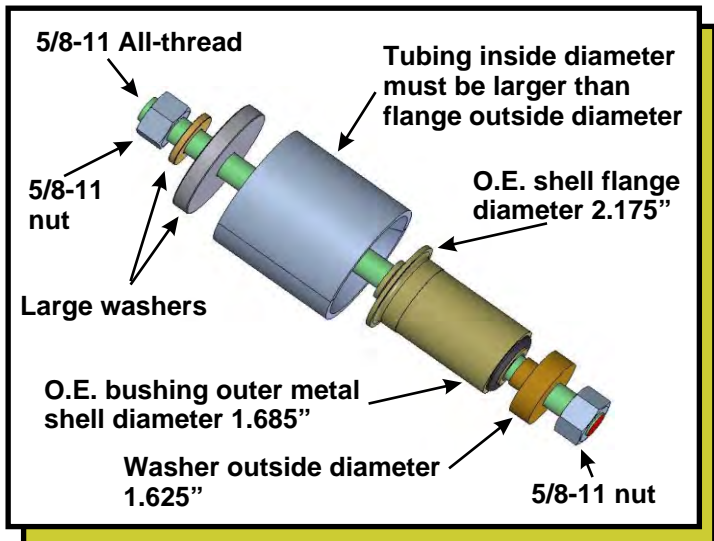
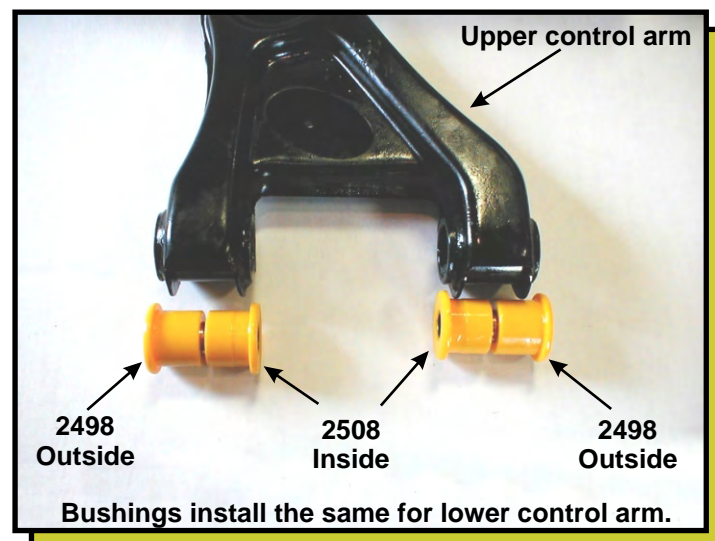

17435