

Installation instructions

For set # 3.3148 / 3.3149

65-70 Chevy Impala & Caprice

Rear Control Arm Bushings



Apply light heat evenly around the outside of the outer metal casing, just enough to break the bond with the rubber. When you see light smoke coming from the sides of the bushing the bond should be broken. At no time should there be any flames coming from the rubber, if there are any flames, you need to back off with the heat. Use caution when pushing the old rubber and inner metal sleeve out, they are preloaded and might eject quickly! Let the outer metal casing cool off before cleaning the inside.

The Thrust washers are designed to prevent the control arm from walking side to side by accepting side load pressure created upon hard cornering. Most kits contain more than one part #. It is very important to install them at the correct location. "SEE ILLUSTRATION # 1".

The original shells in the upper control arm and / or arms must be pressed up to the stepped area of the flanged end. Measurement from control arm to end of bushing (new polyurethane) installed in original shell should be approximately 2". "SEE ILLUSTRATION # 2" NOTE: Thrust washers vary in sizes. Illustrations is only to show location and direction of installation (opposite of bushing flange).

ILLUSTRATION # 2

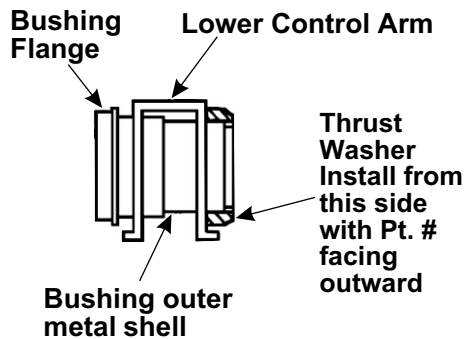
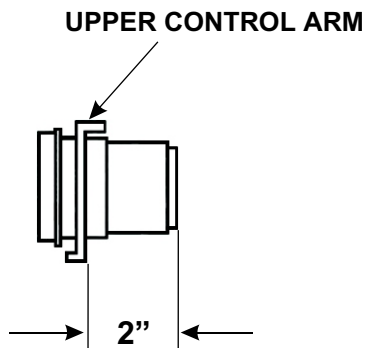

3.3148 (SINGLE UPPER CONTROL ARM)
3.3149 (DOUBLE UPPER CONTROL ARMS)

ILLUSTRATION # 1

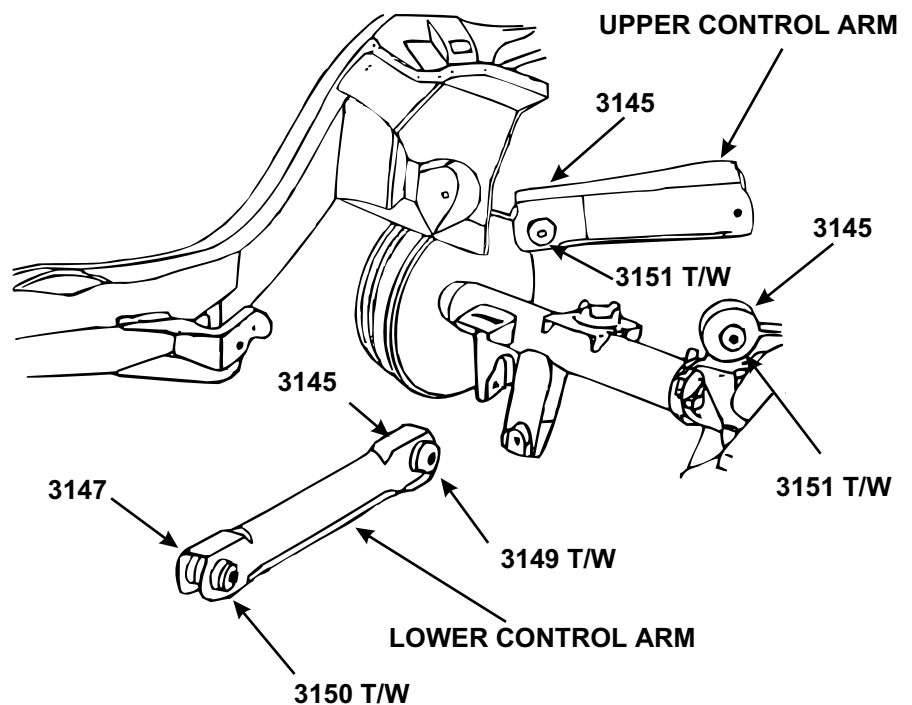

17057