

General Purpose Control Arm Bushing Instructions

(Diagram may not represent your exact bushing assembly)



If your new bushing kit does not have new shells and / or sleeves, you must reuse the original shells and / or sleeves.

Cam Bolt style Bushing's use a special washer on each end of the sleeve. To remove these washers, use a small punch through center of sleeve and tap lightly. When new washers are not supplied in kit, originals must be reused.

For ease of installation of bushing and sleeve (or new shell when supplied) disassemble new bushing unit. (When supplied install shell first). Grease I.D. of shell. Grease bushing and install in shell. Grease sleeve and install in bushing.

Note:

When a control arm shaft is used, it must be in position before installing bushings and /or new shells. All washers, or spacers on shaft must be reused, and installed in correct location before installing new bushings.

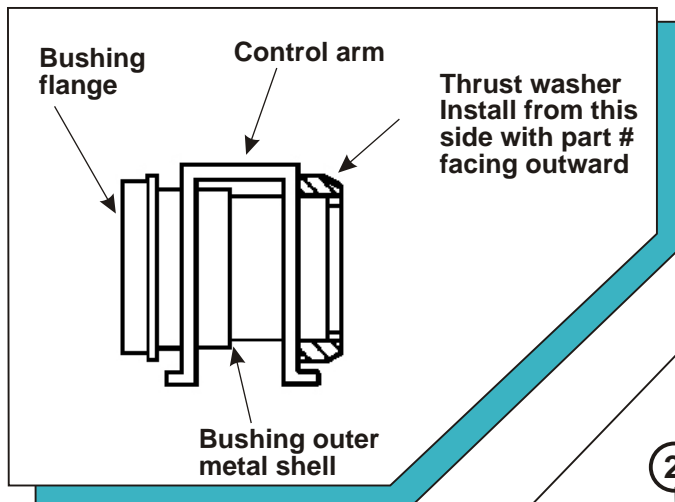
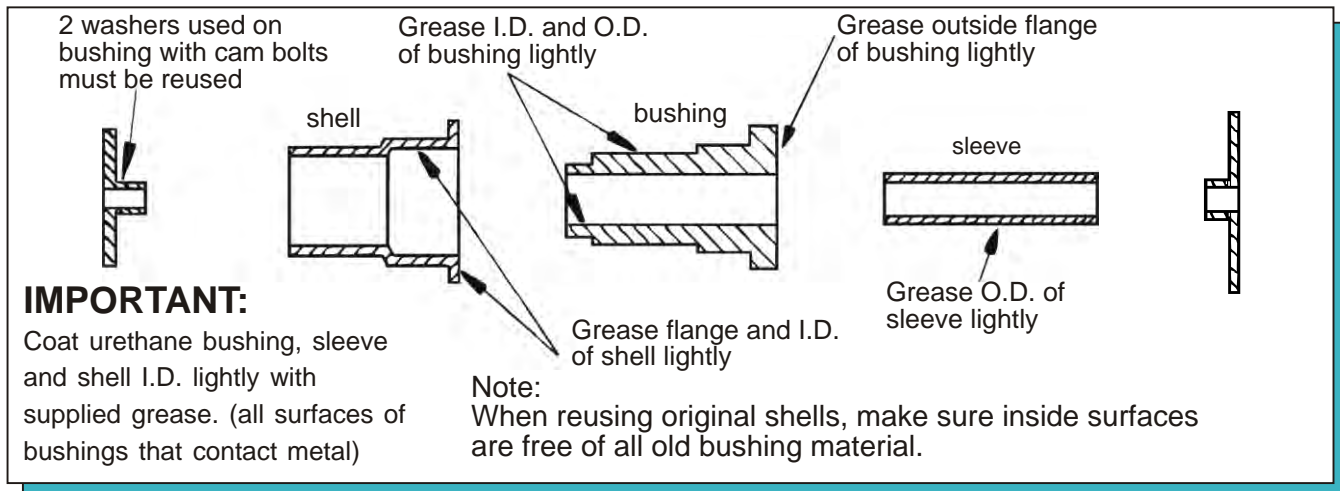

The thrust washers are designed to prevent the control arm from walking side-to-side by accepting side load pressure created during hard cornering. Most kits contain more than one part #. It is very important to install them at the correct location. **See illustration for your set #.**

- Set # 2-3101**
 Position #1 3118
 Position #2 3116
 Position #3 3117
 Position #4 3138

- Set # 2-3102**
 Position #1 3128 *
 Position #2 3116
 Position #3 3117
 Position #4 3138

Select Track

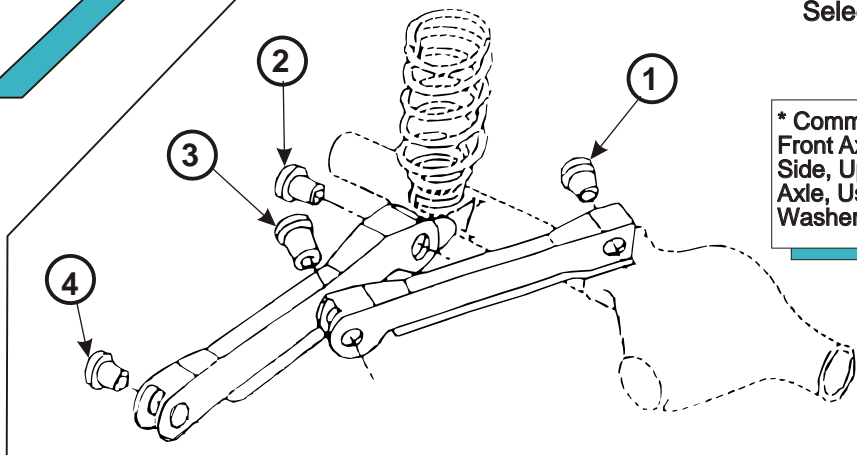

* Command Track Front Axle, Right Side, Upper At Axle, Uses Thrust Washer # 3118