

Installation Instructions for set # 16-8108 92-96 Honda Prelude

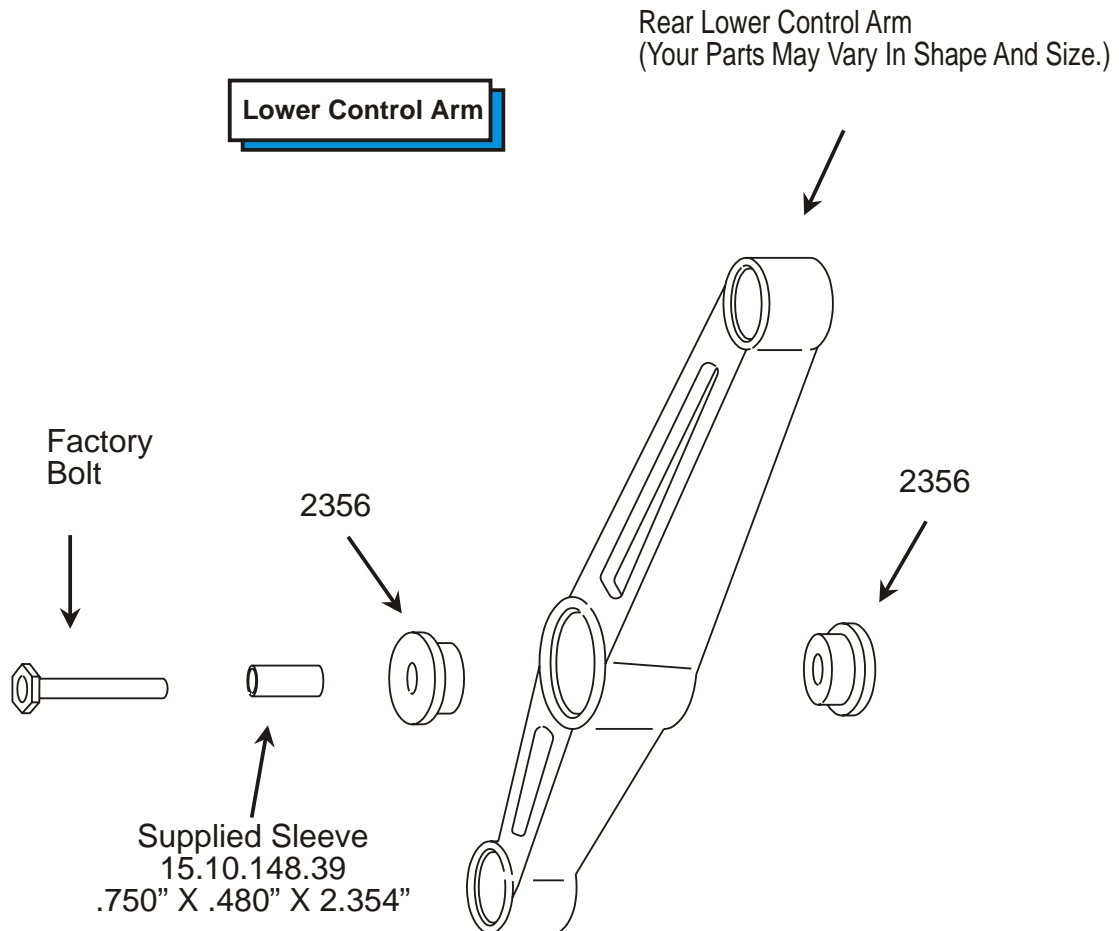

It is recommended that if you are unfamiliar with this type of work that you refer to a qualified service center specializing in this type of work. It is also recommended that if you choose to do this work yourself that a factory service manual be obtained for the proper procedures pertaining to removal, replacement and proper torque specifications for your vehicle. This instruction set is intended as a guideline for the safe installation of Energy Suspension's polyurethane bushings, once you have removed the factory components from your vehicle.

1. Properly support the vehicle on the frame.
2. Unbolt the shock/strut assembly from the vehicle. Remove the top spring hat from the assembly. Use extreme caution!!! Follow procedure in Factory manual or major injury may occur!!!
3. Remove the rubber bushing at the top of the shock/strut. There will be two identical bushing. Replace the bushing using the original hardware. Reinstall the shock/strut assembly, but only tighten the top mounts.
4. Remove the lower control arm from the vehicle. Remove the lower shock/strut bushing including the shell from the lower control arm. A hydraulic press will be needed. Clean the hole/barrel in the control arm that you just removed the bushing from. Lubricate the inside of the hole/barrel. Grease all sides of the bushing that contact metal. Press in the Energy Suspension bushing. Grease the sleeve and press into the bushing. See diagram.
5. Reassemble the control arm onto the vehicle. Tighten all fasteners to factory specs.



17266