

Installation Instructions

Set #16-3112

92-96 Honda Prelude



Note: It is recommended that this set be professionally installed if you are unfamiliar with this type of work, and a factory service manual be purchased prior to performing any work on your vehicle for proper disassembly, reassembly and torque specs. These instructions are intended for bushing removal and install of Energy Suspension polyurethane bushings, once you have removed the factory component from your vehicle.

1. Properly support the vehicle on the frame.
2. Unbolt the upper control arm and pivot bushing assembly from the vehicle. Unbolt the upper control arm from the pivot bushing assembly (Note the position of the pivot assembly as you must reassemble them the same way.).
3. Remove the rubber bushing and shells from the pivot bushing assembly. A hydraulic press will be needed. Clean the pivot bushing assembly and lubricate the inside of the barrel. Grease all sides of the bushing that contact metal. Press in the Energy Suspension bushing from each side. Grease and install the sleeve. See diagram.
4. Reassemble and reinstall the upper control arm assembly onto the vehicle.
5. Remove the lower control arm.
6. Press out the inner control arm bushing including it's shell from the control arm.
7. Grease the I.D. of the lower control arm (where the shell was). Grease the Energy Suspension bushing. Grease all sides of the bushing that contact metal.
8. Install the bushings. There are two bushing for this location. Grease the sleeve and install the sleeve.
9. Reassemble the control arm onto the vehicle. Tighten all fasteners to factory specs.
10. Perform a complete wheel alignment after completion of work.

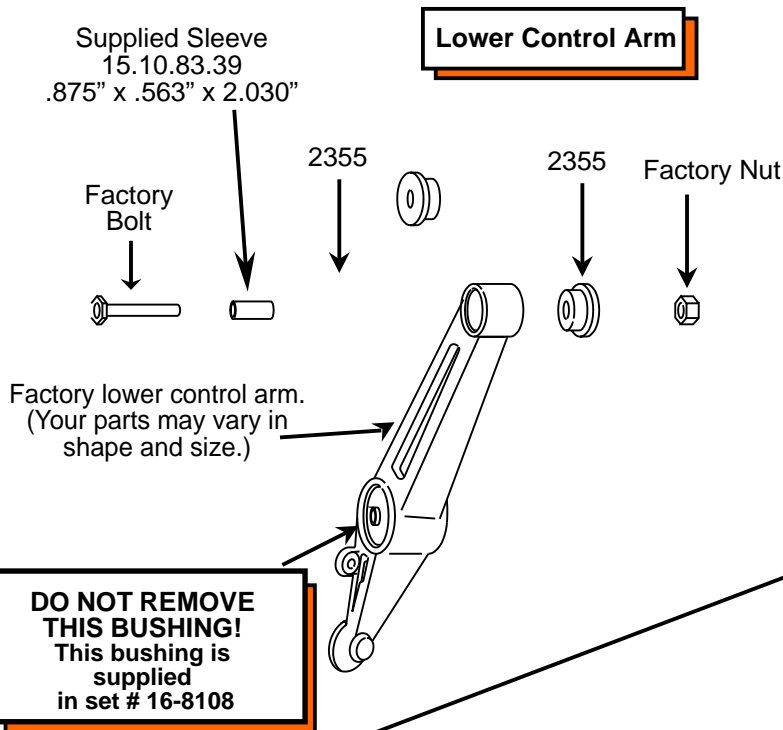

Other Energy Suspension Sets Available for this vehicle:

16-8108	Rear shock bushing set
16-7105	Rear raidus arm set
16-6103	Rear spring pad set
16-6104	Rear bump stop set

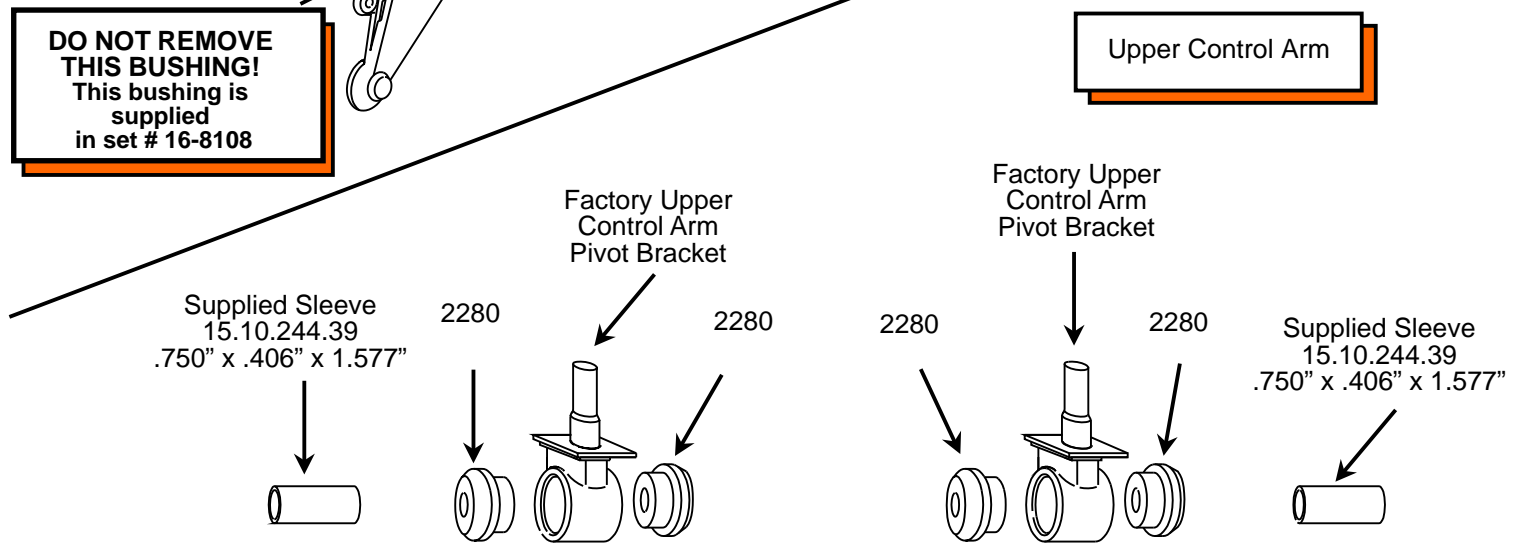

Inst.#17265