

Installation instructions

For set # 7.1117
95-98 Nissan 240sx



Note: It is recommended that this set be professionally installed if you are unfamiliar with this type of work, and a factory service manual be purchased prior to performing any work on your vehicle for proper disassembly, reassembly and torque specs. These instructions are intended for bushing removal and install of Energy Suspension polyurethane bushings, once you have removed the factory component from your vehicle.

Remove the stock bushings from the sub frame using heat rather than a hydraulic press due to the size of the sub frame.

Apply light heat evenly around the outside of the outer metal casing, just enough to break the bond with the rubber. When you see light smoke coming from the sides of the bushing the bond should be broken. At no time should there be any flames coming from the rubber, if there are any flames, you need to back off with the heat. Just push the old rubber and inner metal sleeve out. Let the outer metal casing cool off before cleaning the inside.

Cut away the rubber lip prior to applying heat to allow the old bushing to come out



Using a hammer and cold chisel, remove the 2 inner rings. Clean the remaining rubber and rust prior to installing new bushing.

NOTE: Do not bend the 6 metal tabs, they need to support the new bushing.

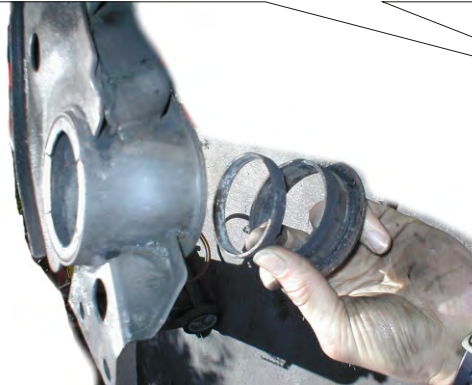

Part List:

- 4 - 4222 Upper frame bushing
- 4 - 4223 Lower frame bushing
- 4 - 15.10.578.39 Sleeve 1.250" x .858" x 2.710"

NOTE: Take care not to use excessive heat near other suspension components to avoid melting vital rubber suspension bushings.

It may be necessary to remove the suspension components from the sub frame prior to applying heat.

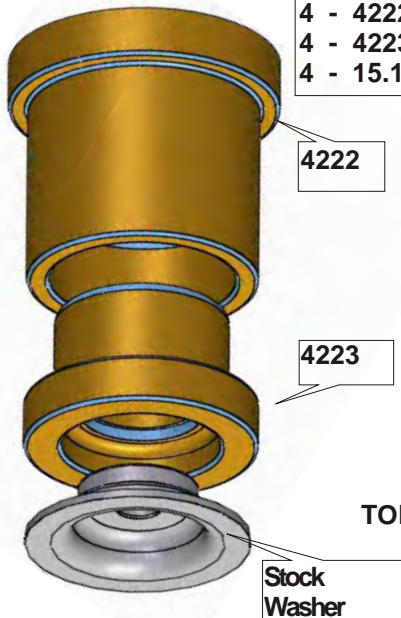

GREASE ALL PARTS THAT COME INTO CONTACT WITH POLYURETHANE

Learn more about suspension parts on our website.