

Installation instructions

For set # 5.3140 LX Platform RWD



It is recommended that if you are unfamiliar with this type of work that you refer to a qualified service center specializing in this type of work. It is also recommended that if you choose to do this work yourself that a factory service manual be obtained for the proper procedures pertaining to removal, replacement and proper torque specifications for your vehicle. This instruction set is intended as a guideline for the safe installation of Energy Suspension's polyurethane bushings, once you have removed the factory components from your vehicle.

Parts list:

- 4 - 2848 (upper control arm bushing)
- 4 - 15.10.490.39 (upper sleeve .875" x .563" x 2.350")
- 4 - 2846 (lower control arm & tension strut bushing)
- 4 - 2847 (lower control arm & tension strut bushing)
- 4 - 15.10.631.39 (lower sleeve 1.250" x .563" x 3.065")
- 1 - 9.11113 (grease)
- 1 - 17562 (this instruction sheet)

Fastener Torque:

- Lower Control Arm Cradle Nut - 130 Ft. Lbs.
- Lower Control Arm Ball Joint Nut - 50 Ft. Lbs. +90° Turn
- Tension Strut Cradle Nut - 130 Ft. Lbs.
- Tension Strut Ball Joint Nut - 50 Ft. Lbs. +90° Turn
- Shock Absorber Lower Mounting Bolt - 128 Ft. Lbs.
- Shock Absorber Upper Mounting Nuts - 20 Ft. Lbs. or 239 In. Lbs.
- Stabilizer Bar Endlink Nuts - 108 Ft. Lbs.
- Sway Bar Bracket Bolts - 44 Ft. Lbs.
- Upper Control Arm Ball Joint Nuts - 35 Ft. Lbs. +90° Turn
- Upper Control Arm Body Nuts - 55 Ft. Lbs.
- Outer Tie Rod Ball Joint Nut - 63 Ft. Lbs.

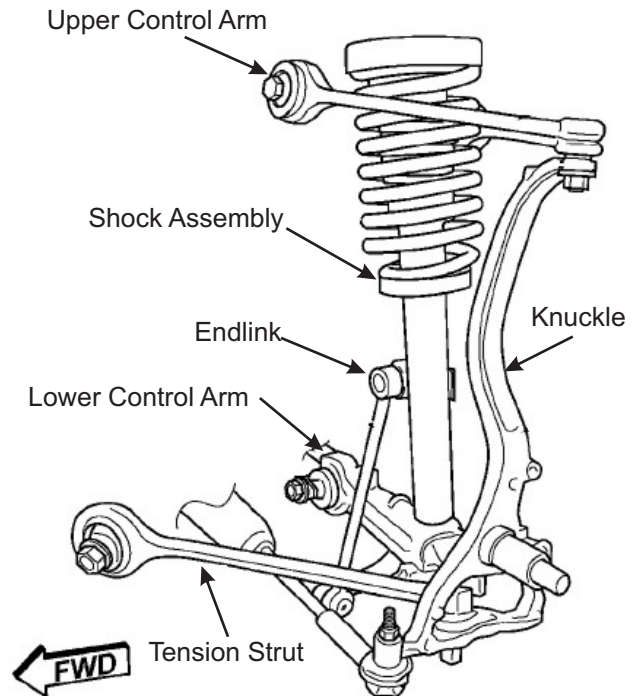

Properly support the vehicle on the frame and remove the upper control arm from the vehicle. Remove the rubber bushing (DO NOT REMOVE O.E. OUTER METAL SHELL FROM UPPER CONTROL ARM). You can do this by heating the exposed circumference of the shell where it contacts the arm. USE EXTREME CAUTION WHEN HEATING AND REMOVING THE OLD RUBER BUSHING AS THEY ARE UNDER PRE-LOAD AND CAN "SHOOT" OUT OF THE SHELL. Make sure to keep the flame moving and not to hold it in one spot for too long. It is usually best to work the flame around the outside of the bushing in a circle. When sizzling/smoke is seen, the bond between the bushing and sleeve is broken and the bushing can be carefully pushed out with pliers or a screwdriver. Once bushing/sleeve is out, clean all scraps of rubber from ID of shell as preparation for new bushing. Grease all sides of the bushing that contact metal. Press in the Energy Suspension bushing. Note: On the upper control arm, the bushings have a part number engraved in them. The P/N 2848 on each bushing must be facing toward each other. (see diagram). Grease and install the sleeve. Reinstall the upper control arm assembly onto the vehicle. Tighten all fasteners to factory specs.

15.10.490.39
(.875" x .563" x 2.350")

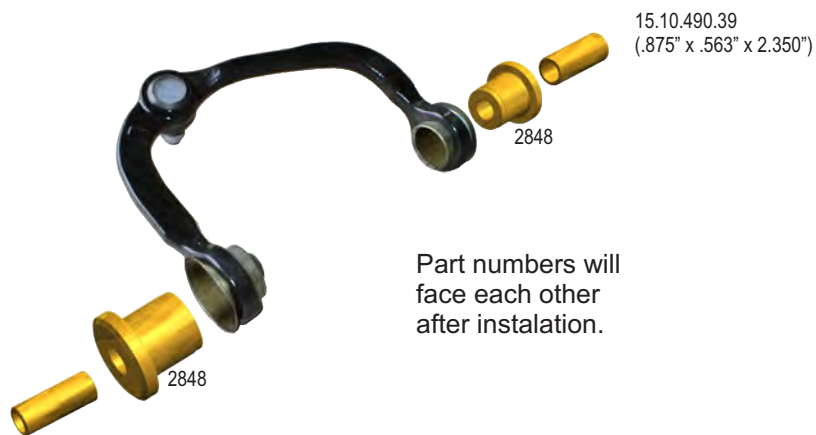

Remove the lower control arm from the vehicle. **WARNING: DO NOT REMOVE SHOCK MOUNTING BUSHING FROM LOWER CONTROL ARM!!!! THIS BUSHING IS NOT & WILL NOT BE SUPPLIED OR A REPLACEMENT MADE FOR THIS POSITION!!! (DO NOT REMOVE O.E. OUTER METAL SHELLS FROM LOWER CONTROL ARM)** Remove the rubber bushing (PIVOT POSITION ONLY) the same way as the upper control arm. Grease the I.D. of the lower control arm shell. Grease all sides of the bushing that will contact metal. Install the new bushings. Driver side P/N 2846 installs to the front and P/N 2847 installs to the rear. Passenger side P/N 2846 installs to the rear P/N 2847 installs to the front. Grease and install the sleeve. Reassemble the lower control arm onto the vehicle. Tighten all fasteners to factory specs.

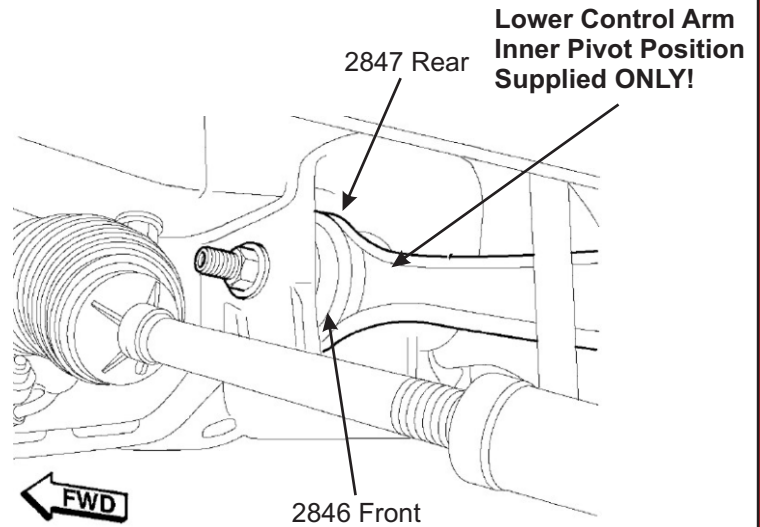
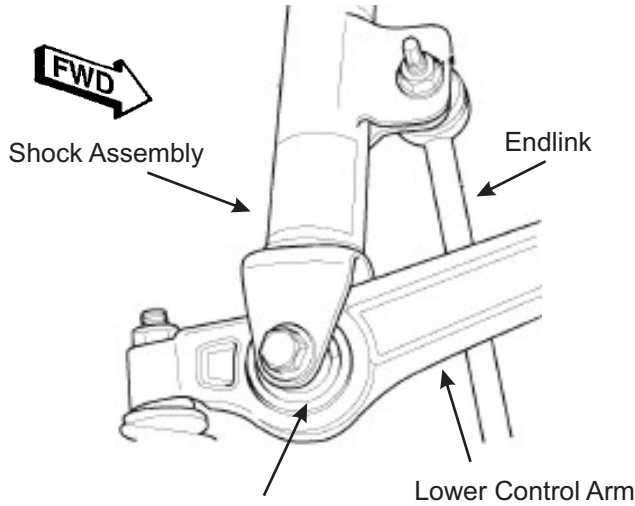

WARNING: DO NOT REMOVE SHOCK MOUNTING BUSHING FROM LOWER CONTROL ARM!!!! THIS BUSHING IS NOT & WILL NOT BE SUPPLIED OR A REPLACEMENT MADE FOR THIS POSITION!!!

Driver Side shown

Remove the front tension strut from the vehicle. **(DO NOT REMOVE O.E. OUTER METAL SHELLS FROM THE FRONT TENSION STRUT)** Remove the rubber bushing the same way as the upper control arm. Grease the I.D. of the lower control arm shell. Grease all sides of the bushing that will contact metal. Install the new bushings. P/N 2846 installs to the outside and P/N 2847 installs to the inside. Grease and install the sleeve. Reassemble the front tension strut into the vehicle. Tighten all fasteners to factory specs. After installation is complete, Energy Suspension recommends an alignment be performed at a qualified alignment shop.

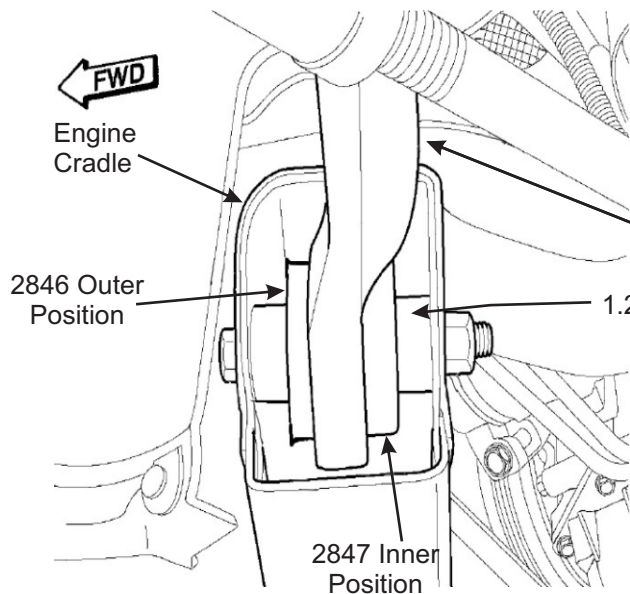

Tension Strut
15.10.631.39
1.250" x .563" x 3.065"
Inner Sleeve

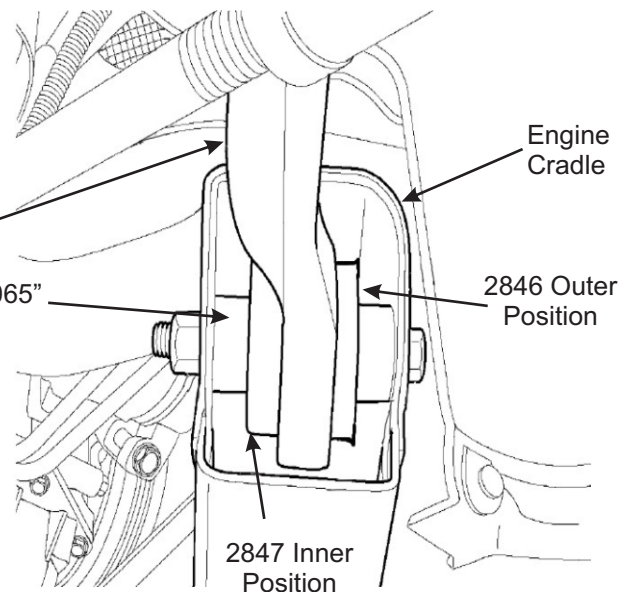

Driver Side shown

Passenger Side shown