

# Installation instructions

For set # 5.3113

90-94 Eagle Talon - All Wheel Drive

90-94 Chrysler Laser - All Wheel Drive

90-94 Mitsubishi Eclipse - All Wheel Drive

**ENERGY**  
**SUSPENSION** 

It is recommended that if you are unfamiliar with this type of work that you refer to a qualified service center specializing in this type of work. It is also recommended that if you choose to do this work yourself that a factory service manual be obtained for the proper procedures pertaining to removal, replacement and proper torque specifications for your vehicle. This instruction set is intended as a guideline for the safe installation of Energy Suspension's polyurethane bushings, once you have removed the factory components from your vehicle.

## Parts list:

- 2 - 3174 Upper control arm bushing.
- 2 - 3175 Upper control arm thrust washer.
- 2 - 15.10.167.39 (sleeve .875" O.D. x .563" I.D. x 1.960" LG).
- 4 - 2126 Rear trailing arm bushing.
- 2 - 15.10.190.39 (sleeve 1.000" O.D. x .563" I.D. x 1.900" LG).
- 4 - 2148 Lower control arm bushing.
- 2 - 15.10.126.39 (sleeve .750" O.D. x .480" I.D. x 2.125" LG).
- 1 - 9.11108 (grease).
- 1 - 17084 (this instruction sheet).

On the upper control arm and rear trailing arm mark eccentric bolt positions before removal and reinstall at same position when reassembling. This will work for initial setting, but vehicle **must** be realigned. The outer metal shells at all 3 positions (upper and lower control arms and trailing arm) must be removed for this bushing set to work. To press out the old bushing including its shell (pivot position) from the upper control arm. A hydraulic press will be needed. The inside diameter of the upper control arm is 40mm (1.575"). When pressing out O.E. Shell, use something smaller than 40mm (1.575"). Support the control arm with thick wall tubing that has a inside diameter bigger than 40mm (1.575") for the O.E. Shell to get pushed in to. The inside diameter of the lower control arm is 32mm (1.260"). The inside diameter of the trailing arm is 45mm (1.772"). Remove any sharp edges that might cut the new polyurethane bushings during installation. Apply grease to all metal parts that contact the polyurethane bushings.

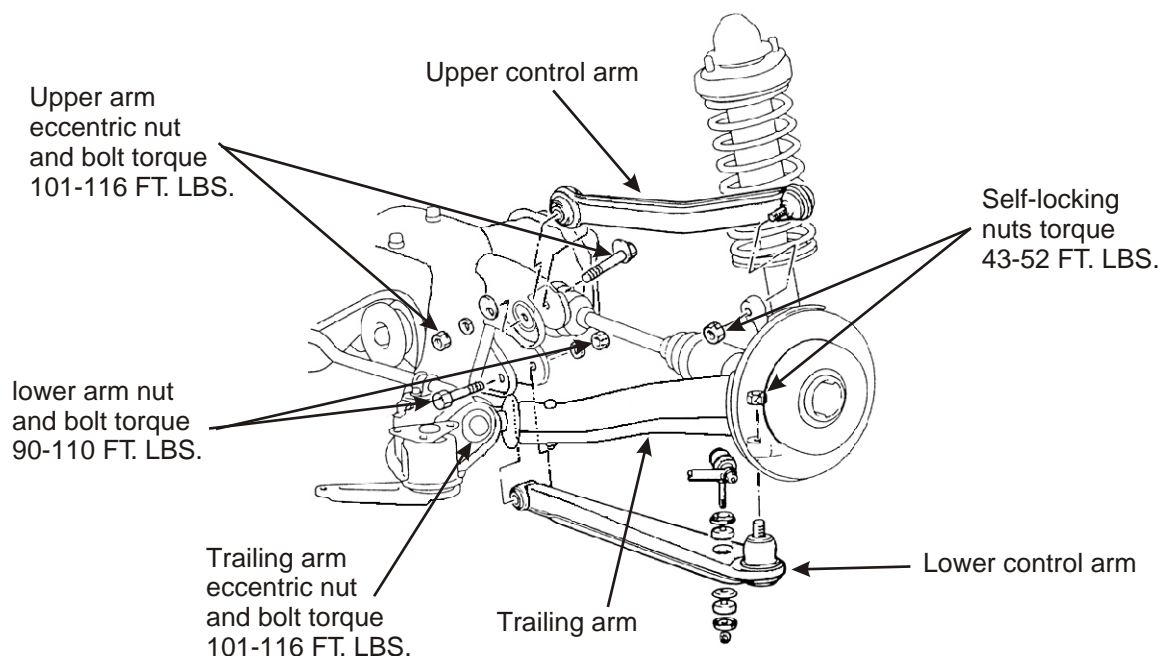

Learn more about suspension parts on our website.