

Instruction Sheet for Set#5-1107



Read entire instruction sheet before performing any work!

1. Remove the grommet inside the passenger side wheel well to gain access to the thru bolt for the right side torque mount (A). Remove thru bolt and then remove 2 remaining bolts. Install the Energy Suspension® inserts and install the 3 supplied ties. **NOTE: The ties must be installed through the #1152 insert first.** See diagram below. Reinstall mount but don't tighten the mounting bolts completely yet. **DO NOT OVERTIGHTEN TIES. Pull tie until the button just touches the insert and stop.**

2. Remove grommet inside driver's side wheel well. Remove the thru bolt. Remove battery and battery tray to allow access to the bolts on the driver's side motor mount. Remove the three bolts and remove the driver's side motor mount (B). Install the Energy Suspension® inserts and reinstall the driver's side motor mount, but do not completely tighten the three bolts yet.

3. Remove thru bolt on front lower torque mount (C). Remove three bolts and install the 2 Energy Suspension® inserts. Reinstall the front mount. Now, **tighten all mounting bolts and thru bolts at all positions to factory specifications.**

17353
11/26/2012
BEL

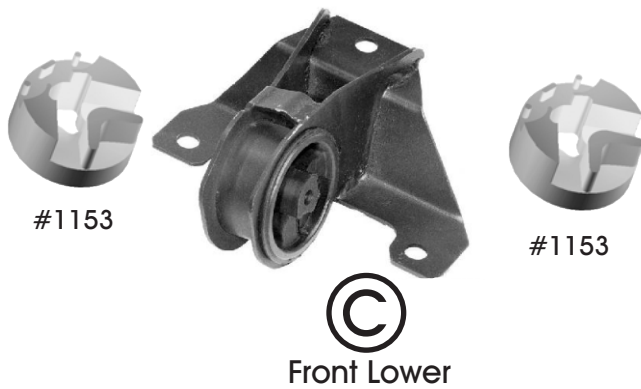

NOTE: Must cut the ties and buttons to relieve the shaded portions depicted in the figure to the right. This allows them to clear the casting without inhibiting the inherent movement of the motor mount. **REMEMBER:** Do not overtighten the ties or they will break when the motor torques.

