

# Set # 4-3132



**NOTE:** Before installation of new bushing, shell and sleeve, disassemble new bushing assembly. First install shell first into arm. Then grease I.D. of shell. Grease bushing and install in shell. Grease sleeve and install in bushing. **(ALL SURFACES OF BUSHINGS THAT CONTACT METAL).** Bushing, sleeve and shell are preassembled at factory for packaging only.

The bushing at the rear mounting position does not fit into the eye with the flange surface against the face of the control arm. (see diagram)

Apply a coat of grease to bushing faces that contact cross-member before putting the control arm into the mounting position.

**\* Read instructions before removing old bushings.**

Flange of outer metal shell does not fit flush with control arm face

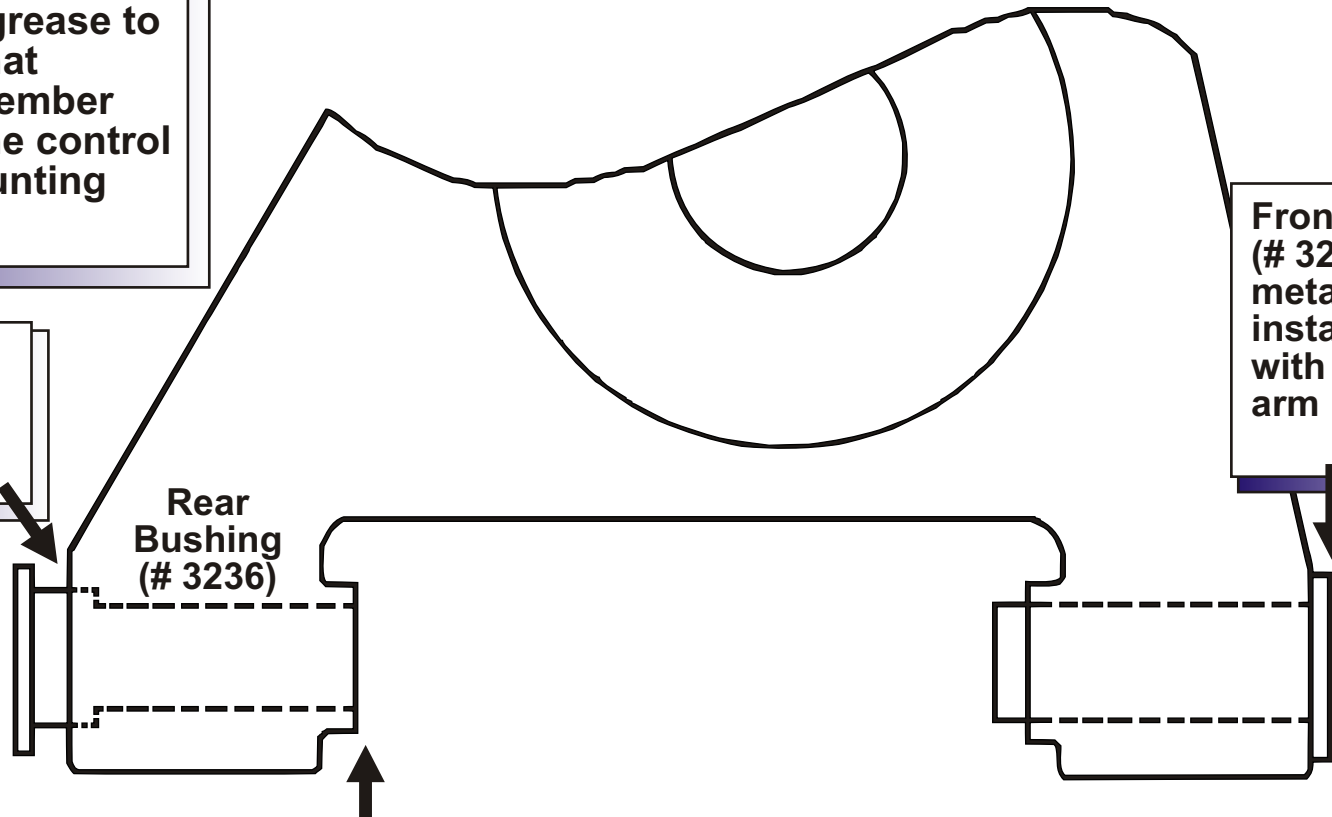

Front bushing (# 3237) outer metal shell installs flush with control arm

The end of outer metal shell should be flush with the end of the control arm eye. Be careful not to collapse control arm when pressing bushing into place.

When installing these new bushings, the urethane bushing may walk slightly out of the shell. If this happens use a vise to reseat bushing into the shell.