

Installation instructions for Set # 4-1104

Ford Multi-application transmission mount.

US patent # 5,551,661

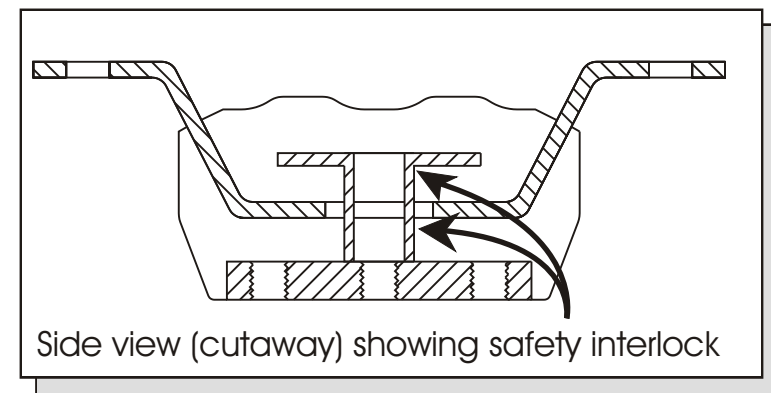
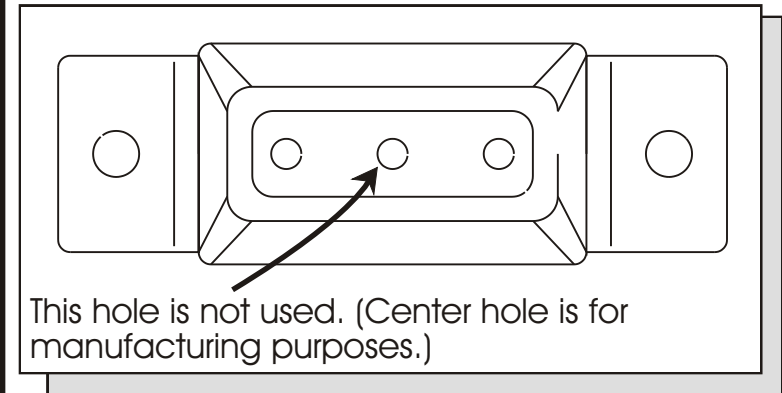
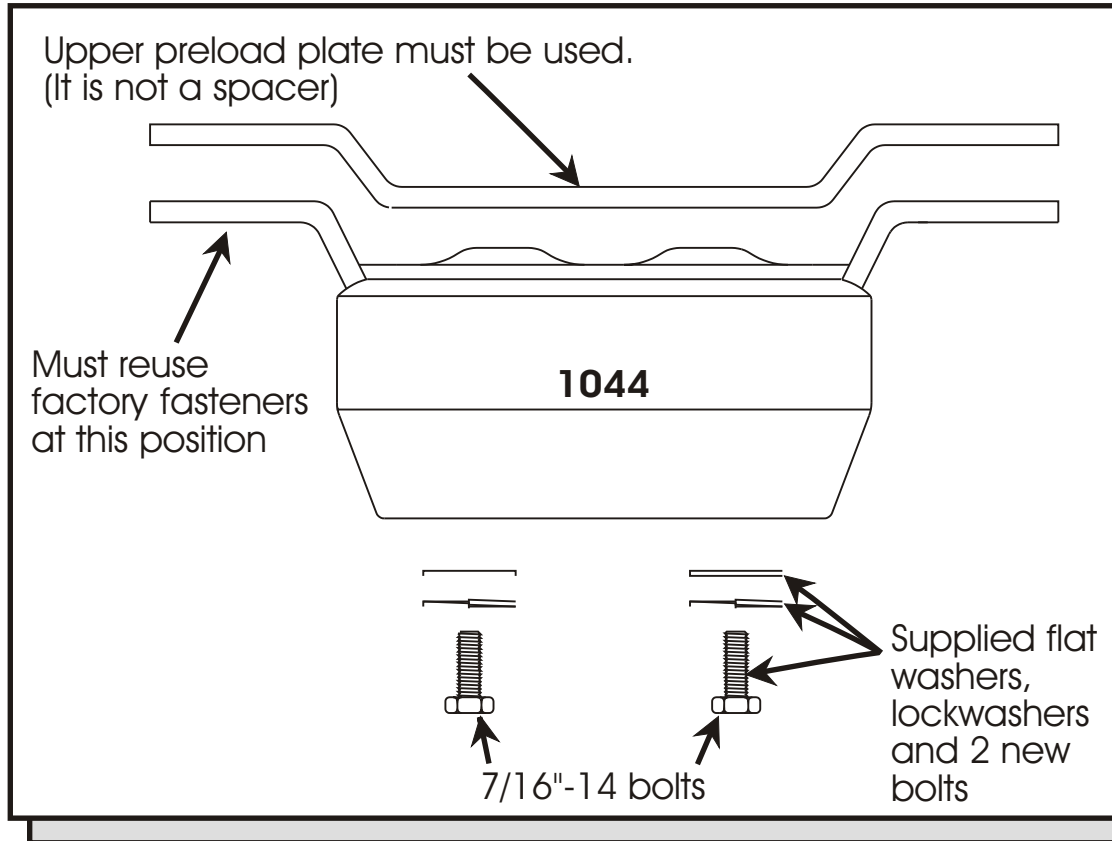

Crossmember center section diagram

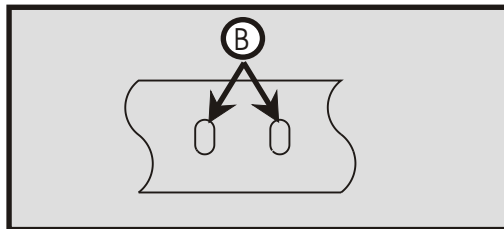

B Before installing the new mount, be sure to check the transmission crossmember for cracks or damage at the slotted hole areas. **On some vehicles, because of the nuts used on the factory studs, it will be necessary to clean out the slots with a file for clearance when using the new bolts.** Repair or replace the crossmember if any damage is evident. On high performance (race condition) applications, reinforcing the area around the mounting point of the crossmember is recommended. This type of crossmember had an inherent problem with stress cracks around the bolt holes. Always check the front engine mounts and replace if necessary.