

## Removal

**Spray all nuts to be removed generously with your favorite rust buster.**

**Note:** When disassembling, note the quantity and positions of any shims that may have been inserted for body alignment. These shims will have to be reused to insure proper body alignment.

**Remember:** Only raise body high enough to remove & replace mounts. Always watch the fan shroud for sufficient clearance when raising the body. When jacking the body use a long enough 2X4 or 4X4 for maximum support. Never put jack directly on body panels.

Install mounts one side at a time with bolts on other side loosened only.

**Retorque to factory specs.**

# Set # 3-4142

# ENERGY SUSPENSION®

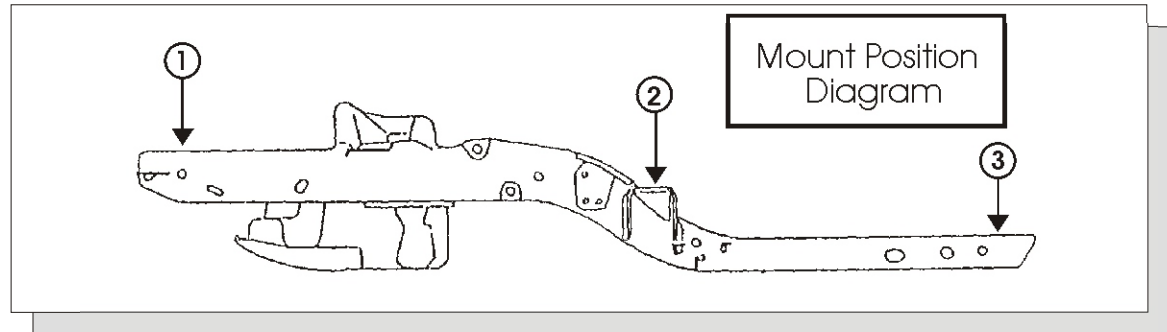

**Parts Diagram**  
(refer below)

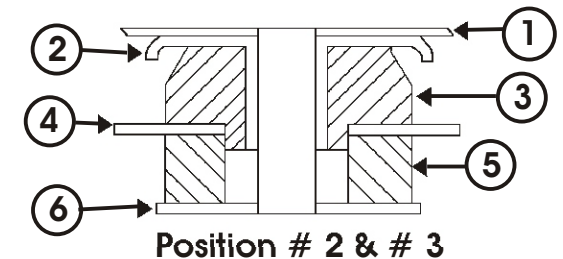
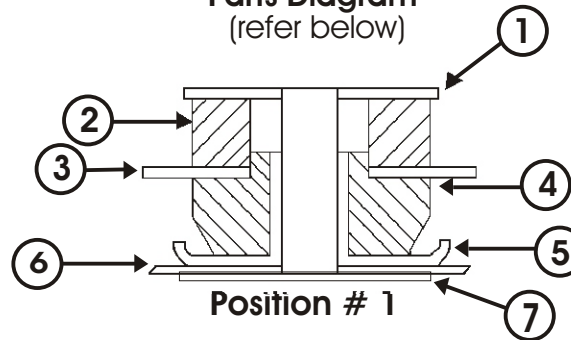

### POSITION # 1

1. Supplied washer (2-1/2"O.D. x 1/2"l.D.)
2. 4002
3. Core support Bracket
4. 4001
5. Supplied washer-sleeve (1.282 O.A.L.)
6. Frame
7. Supplied washer (2-1/2"O.D. x 1/2"l.D.)  
(used on 1/2" Bolt under frame)

NOT shown, but supplied for this position:  
2 - 1/2"-13 x 2-1/2" bolts grd5  
2 - 1/2"-13 Nylock nuts grd5

### POSITION # 2

1. Body
2. Supplied washer-sleeve (1.495"O.A.L.)
3. 4005
4. Frame
5. 4004
6. Supplied washer (2-1/2"O.D. x 5/8"l.D.)

NOT shown, but supplied for this position: 2  
- 5/8"-11 x 3" bolts grd5

### POSITION # 3

1. Body
2. Supplied washer-sleeve (1.410"O.A.L.)
3. 4003
4. Frame
5. 4004
6. Supplied washer (2-1/2"O.D. x 5/8"l.D.)

NOT shown, but supplied for this position: 2  
- 5/8"-11 x 3" bolts grd5