

Removal

Spray all nuts to be removed generously with your favorite rust buster.

Note: When disassembling, note the quantity and positions of any shims that may have been inserted for body alignment. These shims will have to be reused to insure proper body alignment.

Remember: Only raise body high enough to remove & replace mounts. Always watch the fan shroud for sufficient clearance when raising the body. When jacking the body use a long enough 2X4 or 4X4 for maximum support. Never put jack directly on body panels.

Install mounts one side at a time with bolts on other side loosened only.

Retorque to factory specs.

Set # 3-4101

**ENERGY
SUSPENSION®**

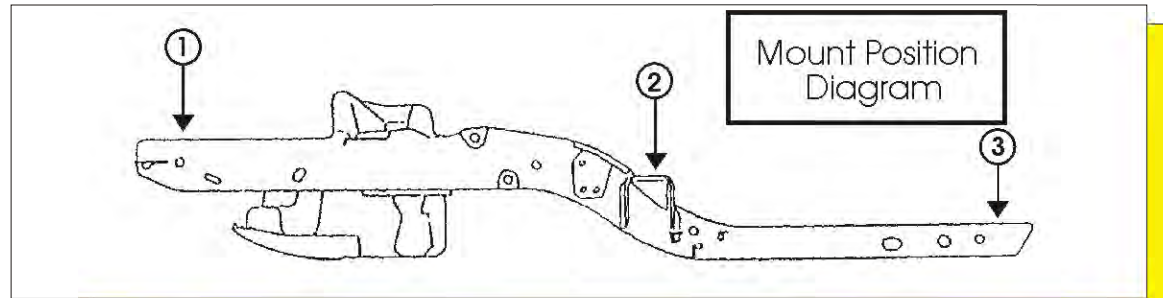

©2000 Energy Suspension. All rights reserved.
May not be reproduced, in any form, or by any means,
without the written consent of Energy Suspension.

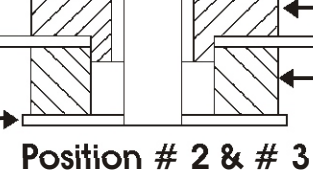
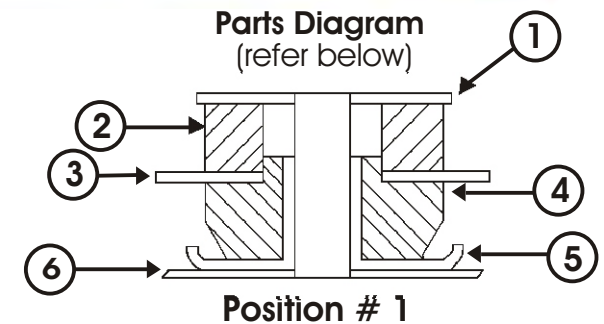

Must re-use original hardware

POSITION # 1

1. Factory washer
2. 4002
3. Core support Bracket
4. 4001
5. Factory sleeve
6. Frame

POSITION # 2

1. Body
2. Factory sleeve
3. 4005
4. Frame
5. 4004
6. Factory washer

POSITION # 3

1. Body
2. Factory sleeve
3. 4003
4. Frame
5. 4004
6. Factory washer