

Installation instructions

For set # 3.3158 & 3.3159



It is recommended that if you are unfamiliar with this type of work that you refer to a qualified service center specializing in this type of work. It is also recommended that if you choose to do this work yourself that a factory service manual be obtained for the proper procedures pertaining to removal, replacement and proper torque specifications for your vehicle. This instruction set is intended as a guideline for the safe installation of Energy Suspension's polyurethane bushings, once you have removed the factory components from your vehicle.

Set # 3.3158	Set # 3.3159
Position #1,2,3	Position #1,2,3
3210 Bushing	3210 Bushing
3213 Thrust washer	3213 Thrust washer
Position # 4	Position # 4
3011 Bushing	3230 Bushing
3231 Thrust washer	3231 Thrust washer

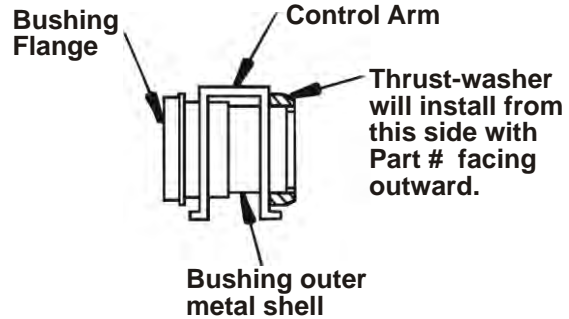

MUST USE EXISTING OUTER METAL SHELLS AT POSITIONS # 1,2 & 3.

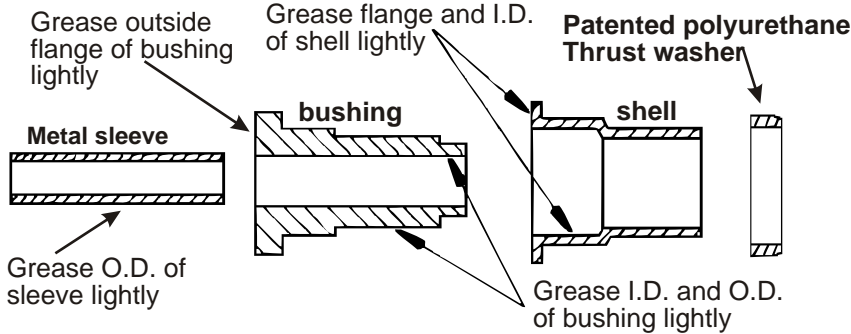

The thrust washers are designed to prevent the control arm from walking side-to-side by accepting side load pressure created during hard cornering. Most kits contain more than one part #. It is very important to install them at the correct location.

See illustration A

If your new bushing kit does not have new shells and/or sleeves, you must reuse the original shells and /or sleeves.

For ease of installation of bushing and sleeve (or new shell when supplied) disassemble new bushing unit. (When supplied install shell first). Grease I.D. of shell. Grease bushing and install in shell. Grease sleeve and install in bushing

IMPORTANT: Coat urethane bushing, sleeve and shell I.D. lightly with supplied grease. (all surfaces of bushings that contact metal)

Note: When reusing original shells, make sure inside surfaces are free of all old bushing material.

