

Installation Instructions For Set # 3.1142

82-02 3RD & 4TH GEN CAMARO / FIREBIRD V8 ONLY

US Patent # 5,551,661, 5,788,206 & 5,788,207



© 2011 Energy Suspension. All rights reserved.
May not be reproduced, in any form, or by any means,
without the written consent of Energy Suspension.

Upper preload plate must be used.
(It is not a spacer.)

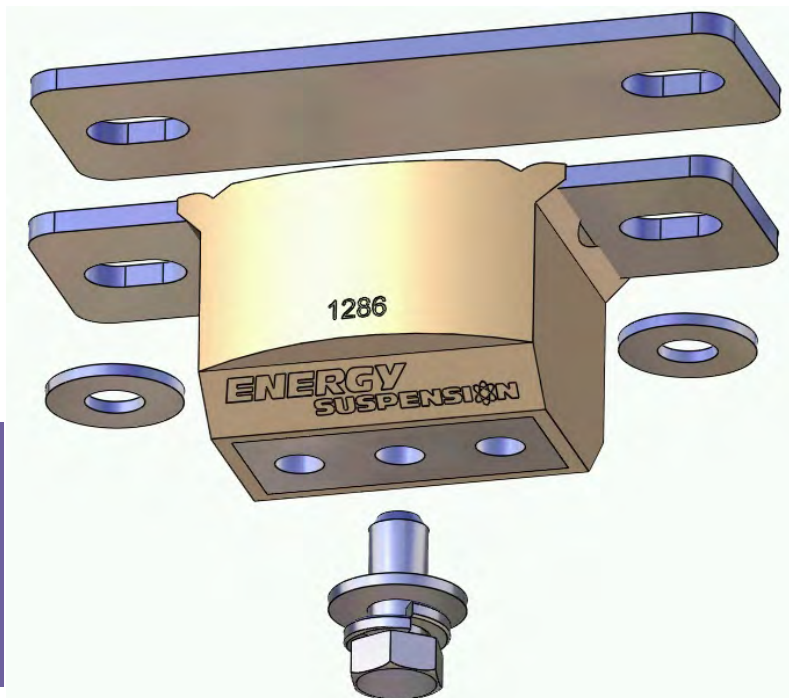

If your vehicle has two (2) flanged bolt heads that hold the mount to the transmission case, DO NOT use supplied flat washers.

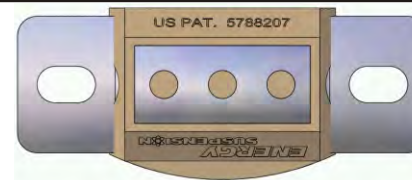

Install mount with radius toward rear of vehicle

The urethane transmission mount was designed for use as a single center bolt mounting application. The other 2 threaded holes are used in our manufacturing process and will not be used.

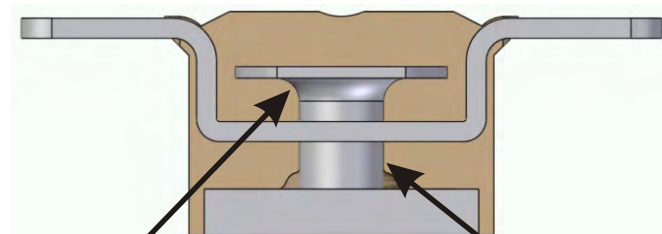

Side view (cutaway) showing safety interlock

Crossmember center section diagram

Single stud style



Before installing the new mount, be sure to check the transmission crossmember for cracks or damage at the slotted hole areas. Repair or replace the crossmember if any damage is evident. On high performance (race condition) applications, reinforcing the area around the mounting point of the crossmember is recommended. This type of crossmember has an inherent problem with stress cracks around the bolt holes. Always check the front engine mounts and replace if necessary.

Tighten all fasteners to factory specifications.