

Installation instructions

For set # 15.5106 (23mm)
99-04 Golf / GTI / Jetta (A4 Chassis)

ENERGY
SUSPENSION 

It is recommended that if you are unfamiliar with this type of work that you refer to a qualified service center specializing in this type of work. It is also recommended that if you choose to do this work yourself that a factory service manual be obtained for the proper procedures pertaining to removal, replacement and proper torque specifications for your vehicle. This instruction sheet is intended as a guideline for the safe installation of Energy Suspension's polyurethane bushings, once you have removed the factory suspension components from your vehicle. Wheel alignment is almost always disturbed when suspension components are removed or replaced. It is recommended that you have the alignment checked on your vehicle at a qualified alignment shop.

PARTS LIST:

- 2 - 5576 23mm bar bushings.
- 2 - 8258 end link bushing at bar.
- 2 - 8259 end link bushing at control arm.
- 4 - 8314 end link bushing.
- 4 - 15.10.442.39 sleeve (.625" x .407" x 1.140").
- 2 - 15.03.46.40 washer (.750" x .312" x .062").
- 2 - 15.05.22.40 bolt (8mm -1.25 pitch x 1.00").
- 1 - 9.11108 grease.

© 2004 Energy Suspension. All rights reserved.
May not be reproduced, in any form, or by any means,
without the written consent of Energy Suspension.

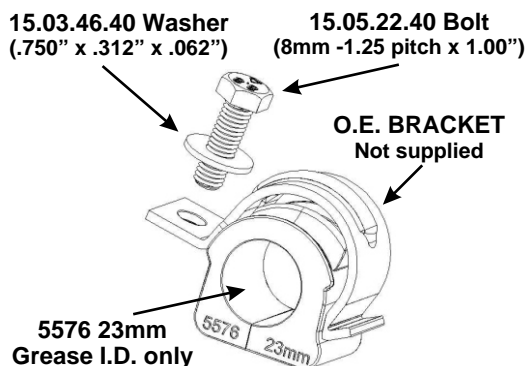

VW A4 Chassis O.E.M. Front Link Assy.

O.E bushings are not bonded and should push out with no problems. Apply a small amount of grease on leading edge of new bushing to ease installation. Shoulder bolt needs to be inserted into part number side of bushing. Not trim side.

1J0 411 315 C 98-99

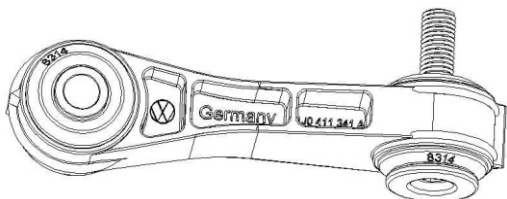

This link uses P/N 8314 and sleeve # 15.10.442.39. Must reuse O.E. shoulder bolt at bar end.

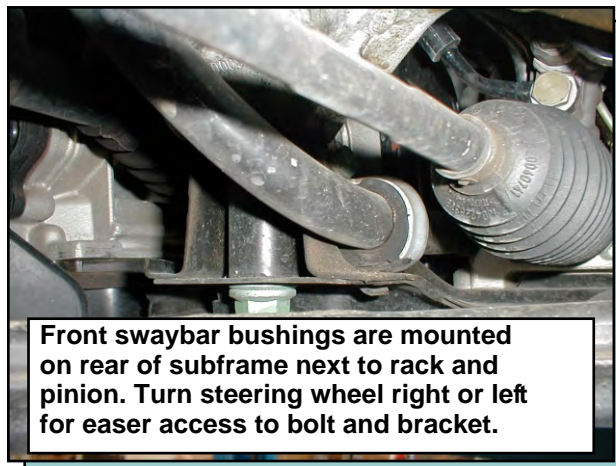

1J0 411 315 G 00 TO 3-01

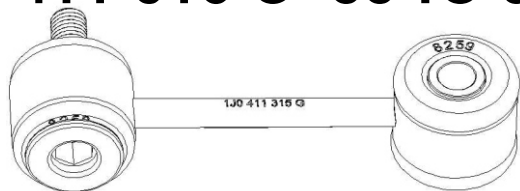

This link uses P/N 8258, 8259 and sleeve # 15.10.442.39. Must reuse O.E. shoulder bolt at bar end.

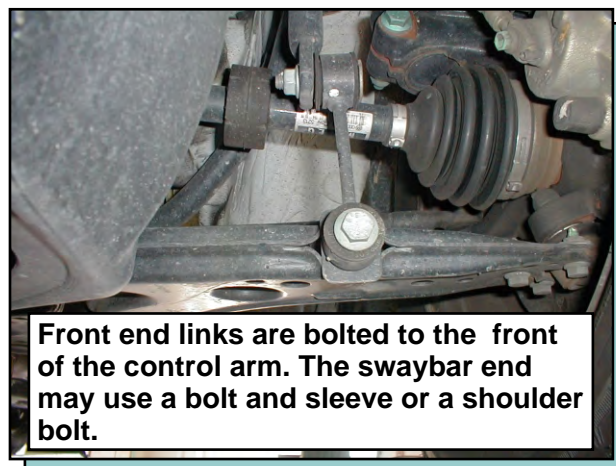

1J0 411 315 H FROM 3-01-03

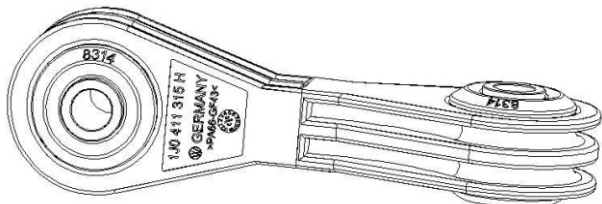

This link uses P/N 8314 and sleeve # 15.10.442.39.