

Installation instructions

For set # 11.3104

1979-85 Mazda RX-7

4-Link control arm bushings

ENERGY
SUSPENSION 

It is recommended that if you are unfamiliar with this type of work that you refer to a qualified service center specializing in this type of work. It is also recommended that if you choose to do this work yourself that a factory service manual be obtained for the proper procedures pertaining to removal, replacement and proper torque specifications for your vehicle. This instruction set is intended as a guideline for the safe installation of Energy Suspension's polyurethane bushings, once you have removed the factory components from your vehicle. Wheel alignment is almost always disturbed when suspension components are removed or replaced. It is recommended that you have the alignment checked on your vehicle at a qualified alignment shop. Energy Suspension recommends that you read over all the installation instructions and check all P/N's and quantities in the parts list before you start. Prior to installation, make sure that your car is in excellent mechanical condition and that there are no suspension or steering related problems. This part has been designed to work only with a car that is in a good state of repair. No matter how carefully we design our parts, this is one area we have no control over and cannot be held responsible.

Parts list:

8 - 2252 (inner bushing).

16 - 2251 (outer bushing).

2 - 15.10.167.39

(sleeve .875"O.D. x .563"I.D. x 1.960"LG).

1 - 17134 (this instruction sheet).

Apply grease to all metal parts that contact the polyurethane bushings.

REMOVING ONE PIECE STYLE BUSHINGS

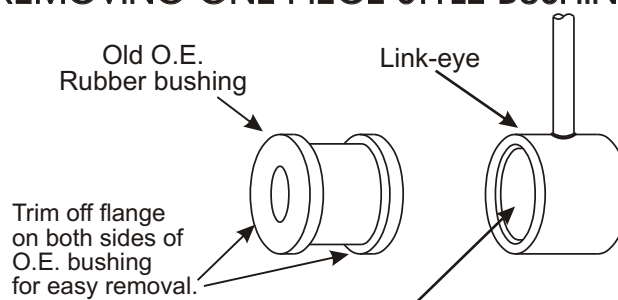

REMEMBER: Remove all old rubber from inside of link eye, this old rubber must be removed.

NOTE: Only remove one control arm at a time. Install the new polyurethane bushings then reinstall back on vehicle. The other 3 control arms will keep the rear end in place and easy to reinstall the bolts.

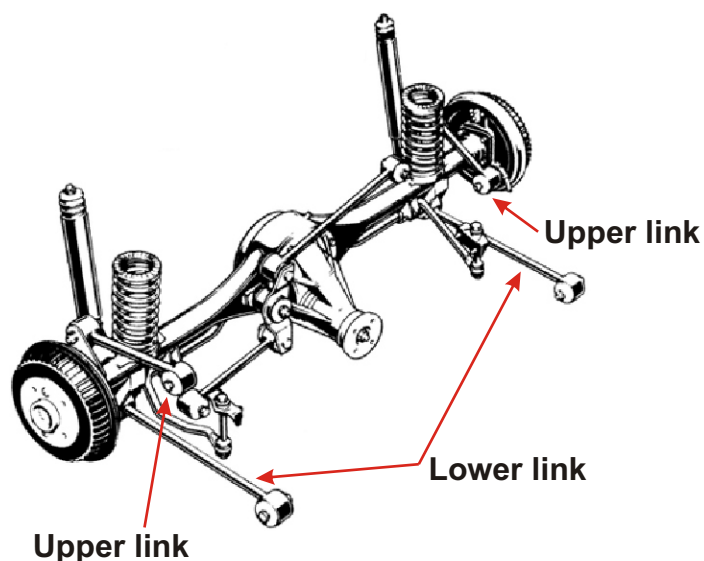

NOTE: All 4 control arms (2 upper 2 lower) use the same bushing for all 8 positions. Factory rubber bushings are not bonded.

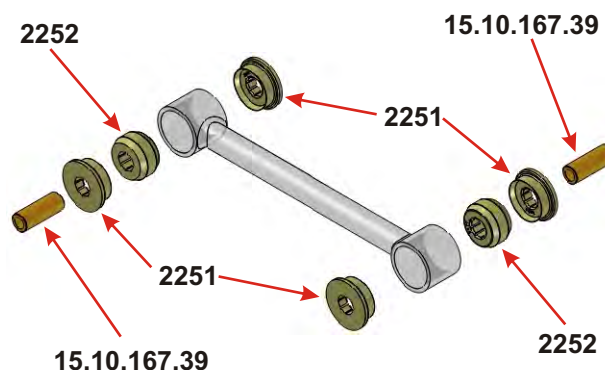

Picture is for position reference only. Actual parts may differ in shape and size.