

Installation Instructions



PRO-KIT # 6390.140

2009-11, Infiniti G37 Sedan, (S), 3.7L V6, Exc. AWD

2011-12, Infiniti G25 Sedan

Kit Contents	Description	Part Number	Qty
	Front Spring	6388.001	2
	Rear Spring	6363.002	2
	Information Kit	EPAK	1
	Instructions	6390.140INST	1

NOTES: Read All Instructions Before Beginning Installation

- **Only qualified mechanics experienced in the installation and removal of suspension components should perform this installation.**
- **Use** of a hoist is highly recommended and will substantially reduce installation time.
- **Never work on or under a vehicle unless it is properly supported by safety stands and wheels are blocked.**
- **PRO-KIT** springs are marked with a .001, for Front and .002, for the Rear.
- **PRO-KIT** springs should be installed with the Eibach Logo right side up. All original stock spring isolators, dampers and tubing should be retained from the stock springs and used when installing the **PRO-KIT** Springs.
- **After** installation, it is always important to inspect and adjust the following if necessary:
 - Wheel alignment such as camber, caster & toe
 - Tire and/or wheel fender clearance, when aftermarket tires and wheels are used.
 - Brake line clearance and attachments
 - Brake anti-locking and anti-skid system sensors
- **Tire Rotation:** In order to increase the life of your tires, it is recommended to rotate your tires every 3,000 miles.
- **For MacPherson Strut type front suspension,** it is important to mark the orientation of the upper perch with respect to the lower perch before disassembly. This orientation must remain the same with the installation of the Pro Kit springs. Noise may result if this procedure is not performed correctly.

Bump Stop Trimming Instructions

Typical Bump-Stop
(Bump-Stop from your vehicle may have different shape)

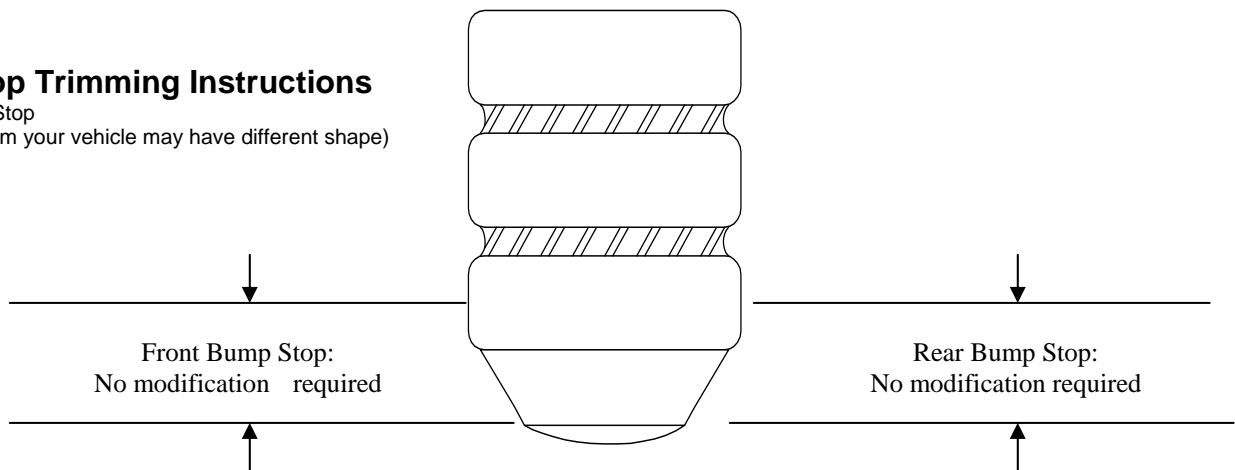

Installation Instructions



Anti-Roll-Kit # 6393.312

2009-2010 Nisan 370Z, Coupe, 3.7L V6
2010 Nisan 370Z. Convertible. 3.7L V6

Kit Contents	Description	Part Number	Qty
	Rear Bar	6393.320R	1
	Anti-Roll Hardware Kit	6393.312HK	1
	Rear Bushing	UB0239	2
	Information Kit	EPAK	1
	Instructions	6393.312INST	1

NOTES: Read All Instructions Before Beginning Installation

- **Only qualified mechanics experienced in the installation and removal of suspension components should perform this installation.**
- **Use** of a hoist and screw jack is highly recommended and will substantially reduce installation time.
- **Installation time:** Is approximate .5 hour with the use of a hoist.
- **Never work on or under a vehicle unless it is properly supported.**
- **Tire Rotation:** In order to increase the life of your tires, it is recommended to rotate your tires every 3,000 miles.

FACTORY REAR BAR REMOVAL

1. Raise the vehicle up and support it with safety stands, then, remove the rear wheels.



Photo 1

2. Remove the four bolts (2 per side) that secure the braces to the bottom of the car. (See Photo 1)



Photo 2

3. Loosen the two bolts at back section of the braces, but do not remove, loosen just enough to let the front of the braces hang down. (See Photo 2)



Photo 3

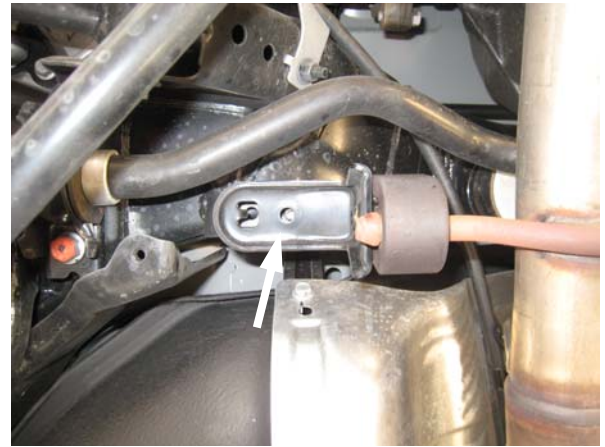

Photo 6

5. Remove the two nuts (one per side) that secure the forward muffler hanger brackets. **(See Photo 6)**
6. You can now lower the muffler down just enough to aid in the removal of the rear OE anti roll bar.



Photo 4

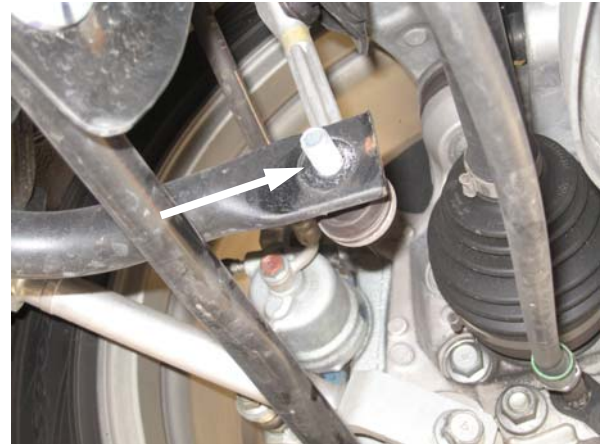

Photo 7

7. Remove the nuts that secure the rear OE end link assembly to both ends of the factory bar. **Note: The end links will be re-used to install the new Eibach rear bar. (See Photo 7)**



Photo 5

4. Using a screw jack support the rear muffler/exhaust, then, remove the 6 bolts, 3 per side, that secure the rear muffler to the underside of the car, then, remove the front bolt that secures the rubber grommet to the hanger. **(See Photos 3, 4 & 5)**



Photo 8

8. Loosen and remove the bolts that secure the OE bushing brackets to the subframe. **(See Photo 8)**

9. You can now safely remove the rear bar from the vehicle. **Note: Be sure to note the orientation of the OE bar, as the new Eibach bar will be installed in the same orientation.**

EIBACH REAR BAR INSTALLATION

1. Apply some poly lubricant to the inside of the new rear bushings.
2. Install the new Eibach bushings onto the Eibach bar.

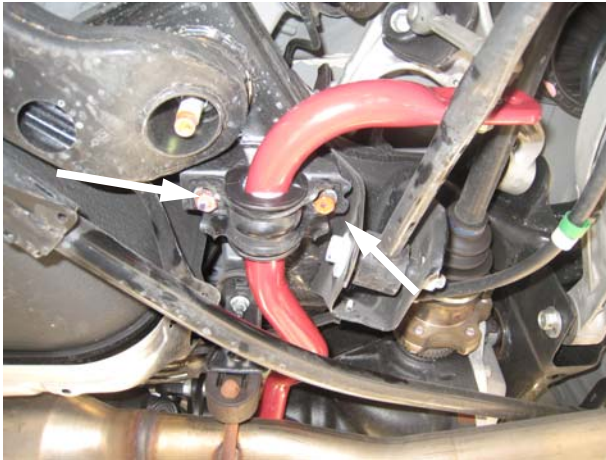

Photo 9

3. Install the Eibach bar into the vehicle and secure the bar using the OE bushing brackets and bolts. (See Photo 9)



Photo 10

4. Secure the end links to the end of the bar using the OE hardware. (See Photo 10)
5. You can now raise the exhaust system back into place and secure it to the OE hanger mounts using the OE hardware, then, secure the braces using the OE hardware as well.



Photo 11

6. Double check to make sure everything is properly positioned, then, tighten all hardware.

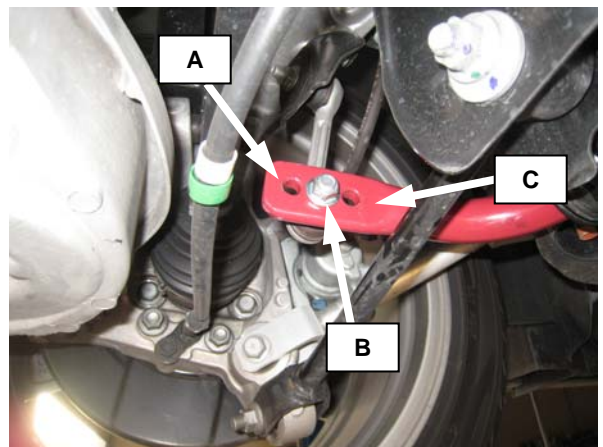

Tuning Rear Bar.

- a) Softest setting.
 - Reduces over-steer
 - Use in rain or on slick roads.
 - Use on rough or bumpy tracks.
 - Increases comfort.
- b) Mid setting.
 - Tuning out under or oversteer
 - For normal driving conditions
 - Dry street driving
- c) Firmest setting.
 - Reduces under-steer
 - Use on dry roads and tracks.
 - Use on smooth roads and tracks.
 - Do not use on wet or slick roads.

Installation Instructions



Anti-Roll-Kit # 6393.310

2009-2010 Nisan 370Z, Coupe, 3.7L V6
2010 Nisan 370Z. Convertible. 3.7L V6

Kit Contents	Description	Part Number	Qty
	Front Bar	6393.320F	1
	Anti-Roll Hardware Kit	6393.310HK	1
	Front Bushing	UB0238	2
	Information Kit	EPAK	1
	Instructions	6393.310INST	1

NOTES: Read All Instructions Before Beginning Installation

- Only qualified mechanics experienced in the installation and removal of suspension components should perform this installation.
- Use of a hoist and screw jack is highly recommended and will substantially reduce installation time.
- **Installation time:** Is approximate .5 hour with the use of a hoist.
- **Never work on or under a vehicle unless it is properly supported.**
- **Tire Rotation:** In order to increase the life of your tires, it is recommended to rotate your tires every 3,000 miles.

FACTORY FRONT BAR REMOVAL

1. Begin by removing the passenger side front tire.



Photo 1

2. Remove the plastic rivets and bolts that secure the plastic cover to the underside of the vehicle (See Photo 1)



Photo 2

3. Loosen and remove the nuts that secure the end links to the ends of the OE anti-roll bar. (See Photo 2)



Photo 3

4. Loosen and remove the nuts that secure the OE bushing brackets to the subframe. **(See Photo 3)**
5. You can now remove the bar from the vehicle. **Note: Be sure to note the orientation of the OE bar as the Eibach bar will be installed in the same orientation.**

EIBACH FRONT BAR INSTALLATION

1. Apply some poly lubricant to the inside of the new front bushings.
2. Installed the new bushings onto the Eibach bar.



Photo 4

3. Install the new Eibach front bar into the vehicle and secure the bar to the vehicle using the OE bushing brackets, and nuts. **(See Photo 4)**



Photo 5

4. Secure the end links to the Eibach front bar using the OE nuts. **(See Photo 5)**
5. Double check to make sure everything is properly positioned, then, tighten all hardware.

FRONT

- a) Softest Setting.
 - **Reduces** under-steer
 - Use in rain or on slick roads.
 - Use on rough or bumpy roads.
 - Increases comfort.
- b) Firmest Setting.
 - **Reduces** over-steer
 - Use on dry roads and tracks.
 - Use on smooth roads and tracks.
 - Do not use on wet or slick roads.