

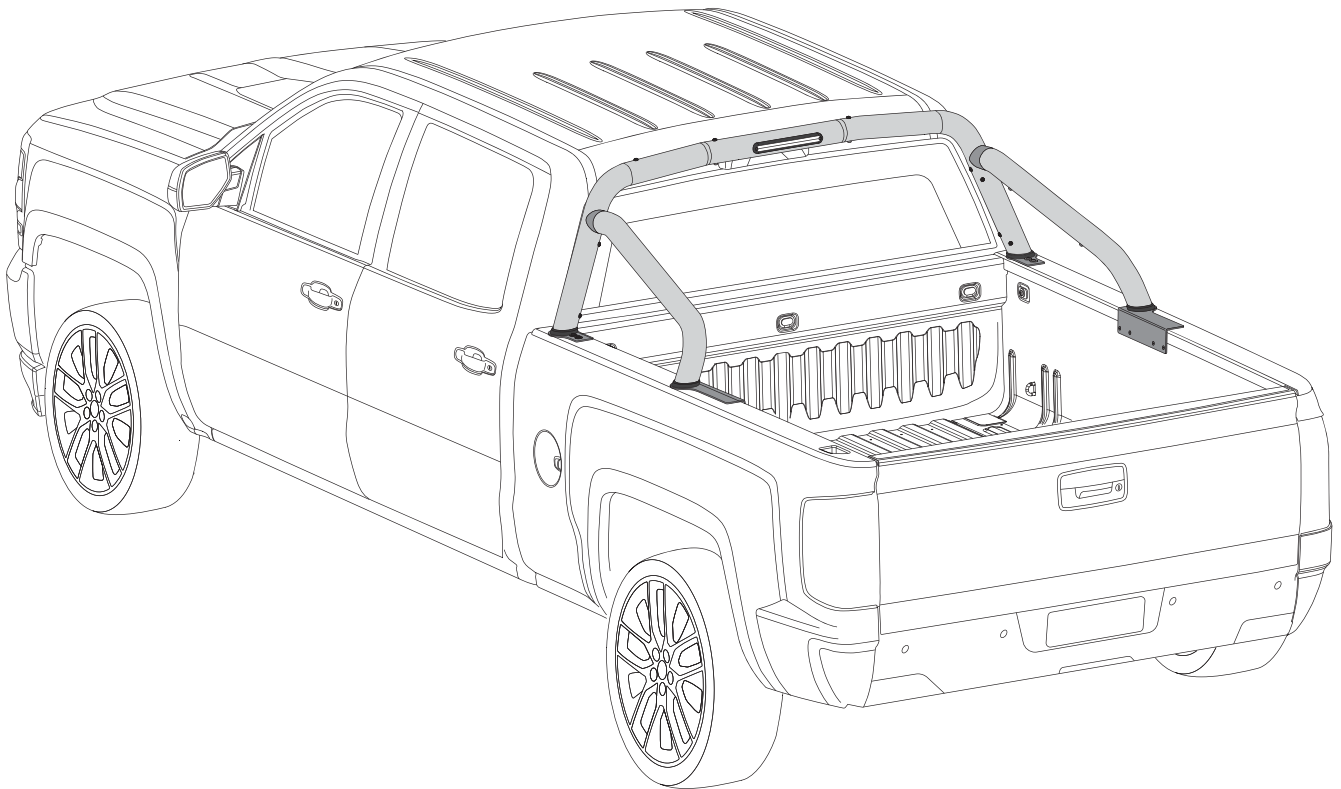

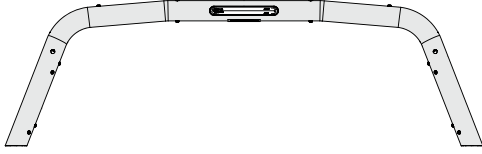







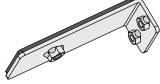
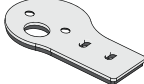

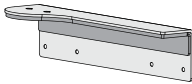
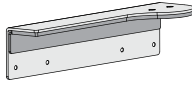
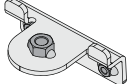

SPORTS BAR WITH INTEGRATED STOP LAMP INSTALLATION INSTRUCTIONS





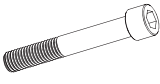



Part Number: SBAR0099
SBAR0102

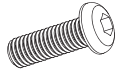

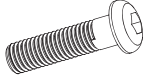
LIST OF PARTS

No.	Item Description	Qty	Image
1	Front Sports Bar Tube	1	
2	Rear Sports Bar Leg LHS	1	
3	Rear Sports Bar Leg RHS	1	
4	Front Tube Attach Bkt	2	
5	Front Foot Plate RHS	1	
6	Front Foot Plate LHS	1	
7	Foot Plate Rear RHS	1	
8	Foot Plate Rear LHS	1	
9	Rear Foot Plate Clamp Bkt	4	
10	Foot Cup Front RHS	1	
11	Foot Cup Front LHS	1	
12	Foot Cup Rear RHS	1	
13	Foot Cup Rear LHS	1	
14	Rear Tube Joiner	2	
15	Grommet	2	
16	Screw Cap	4	
17	M12X80 Tube Joiner Screw	2	
18	Rear Tube Joiner Spacer	2	

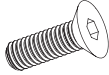
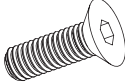
LIST OF PARTS

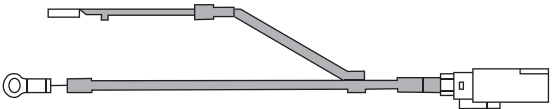
19	M8X25 Foot Plate Bkt Screw	4	
20	M8X24 Foot Plate Washer	4	
21	M10X40 Front Bkt Screw	2	
22	M10X30 Foot Bkt Washer	2	
23	Front Tube Bkt Clamp Plate	2	
24	M10x65 Clamp Bolt	4	
25	M6x16 Clamp Plate Screw	8	
26	M8x30 Foot Plate Screw	8	
27	Loom 1	1	
28	Loom 2	1	
29	Loom 3	1	

RECOMMENDED TOOL LIST

Socket Drive Handle and Extension Bar (½" Drive)	Torque Wrench Rated to at Least 30Nm
Socket Drive Allen Key Long Series M12 (Kincrome)	Phillips Head Screwdriver to Suit M4
Socket Drive Allen Key to Suit M6	Tape Measure
Socket Drive Allen Key to Suit M8	Utility Knife
Socket Drive Allen Key to suit M10	

General Notes

- Read through the fitting instructions before installation of accessory
- Always install the accessory following the fitting instructions. Failure to do so may cause damage to the vehicle or the accessory.
- Ensure all recyclable discarded vehicle/accessory components and packaging are recycled following local recycling regulations.
- It is always recommended that this accessory is fitted by a qualified technician.
- Safely store and protect any removed vehicle components.
- Ensure all bare metal surfaces are protected using Automotive Bare Metal Primer and touch-up paint.
- Remove all metal shavings and dust from all vehicle surfaces if surface is used for accessory installation.
- Ensure all fasteners are torqued to the specifications as per Fitting Instructions if applicable.

Safety Notes

- Check that all work practices comply with safety standards.
- Appropriate clothing & PPE must be worn.
- While using power tools or safety equipment, ensure safe procedures are followed.

Cleaning, Care and Maintenance Notes

- Use a firm water spray to remove any loose dirt from the part, then wash with water, detergent and a soft cloth or sponge.
- Do not use petroleum based solvents.
- Stainless Steel surfaces can be maintained using metal polishes.
Use as recommended.

Important Warning

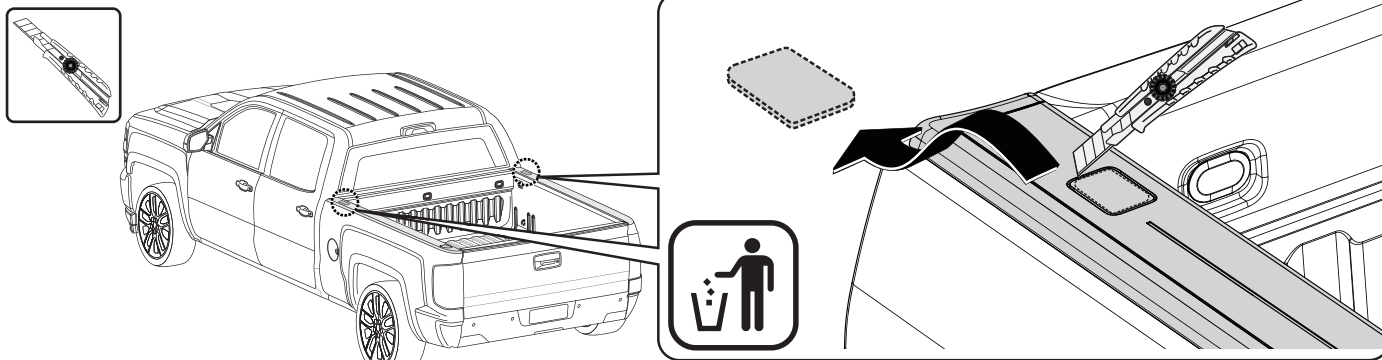

Product is decorative only and is not a safety feature!
Once installed, product does not enhance vehicle structure, integrity or safety.
The sport bar is not designed to prevent injury or death
in the event of a roll-over or other type of accident while the sportbar is installed

FIG. 1

1 Using a Utility Knife carefully cut the plastic bed rail cap at the two front LHS & RHS rectangular inserts to make a clearance hole for the front feet of the Sports Bar. Follow the groove in the plastic bedrail cap and clean all burrs.

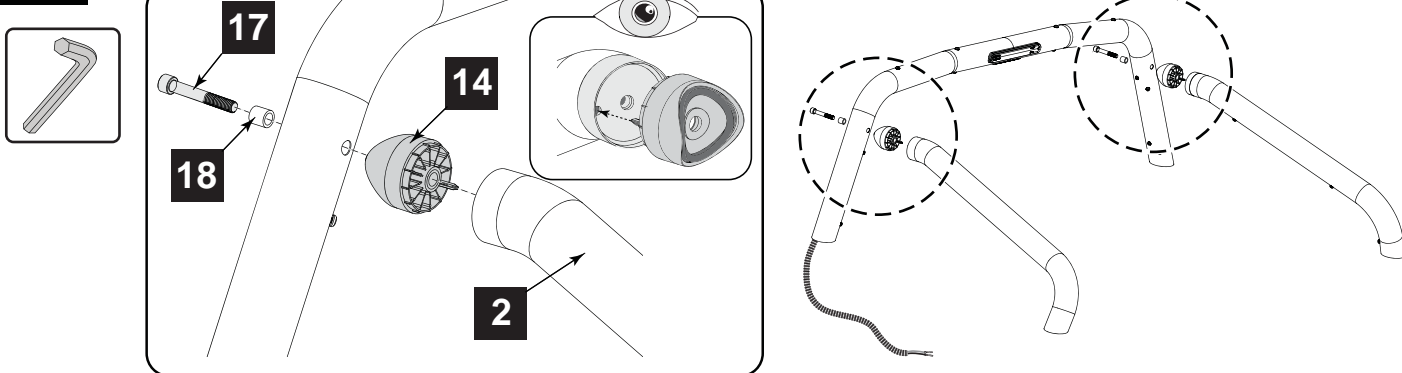
FIG.2

2 Loosely assemble the Front Tube to the LHS side legs with the spacer (18) and the screw (17). Ensure the boss on the connector aligns with the hole in the side leg. Repeat for the opposite side.

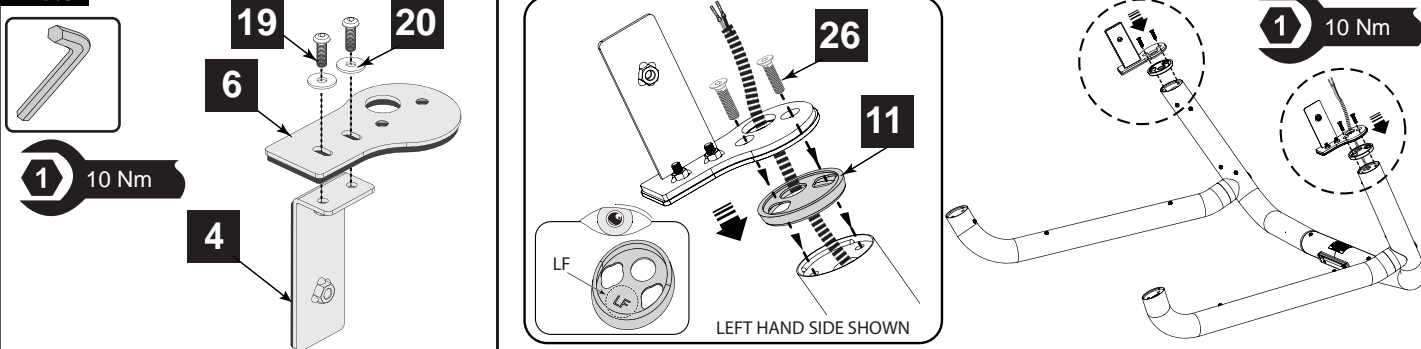
FIG.3

3 Attach the LHS Front Foot Plate (6) to the Front Foot Bracket (4) using the screws (20) and washers (19) to a torque of 10Nm. Attach LHS footcup (11) to the corresponding front tube foot and attach the LHS front foot assembly to the plate in the front tube using screws (26). Ensure that the Stop Light cable runs through the hole in the foot. Repeat for the RHS.

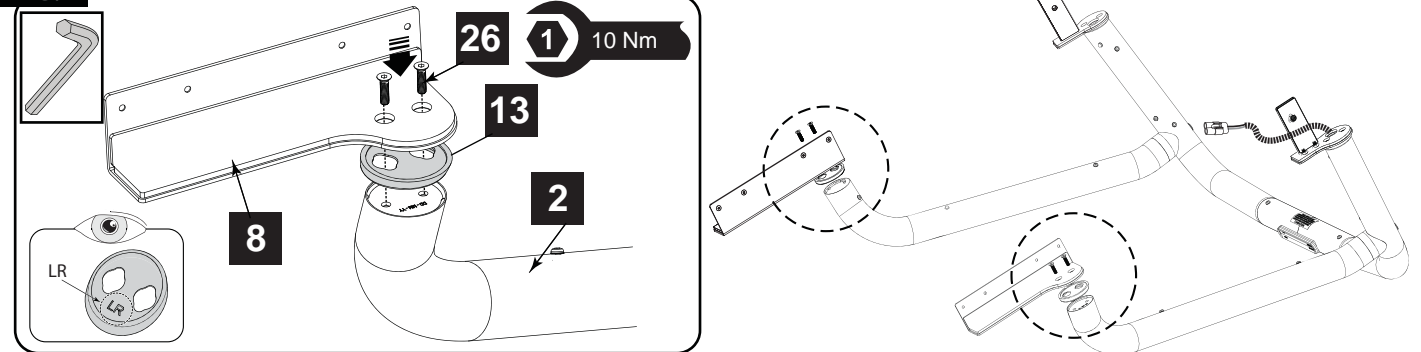
FIG.4

4 Attach a LHS footcup (13) to the rear LH tube (2) foot and attach the LHS rear foot plate (8) to the plate in the tube using two screws (26). Torque to 10Nm.

FIG.5

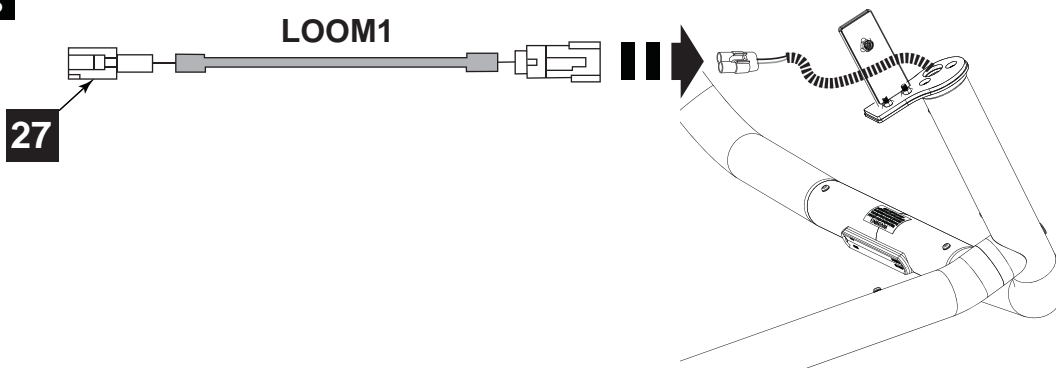

5 Connect the LOOM1 (27) to the SBAR loom as shown.

FIG.6

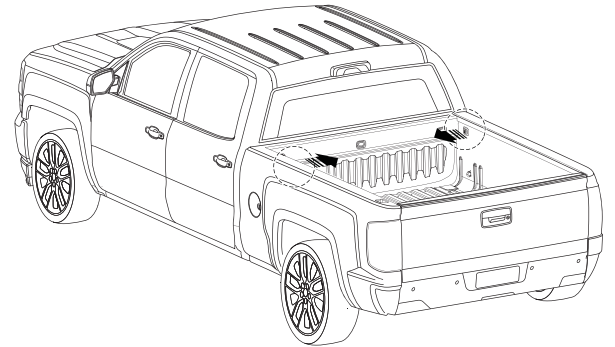
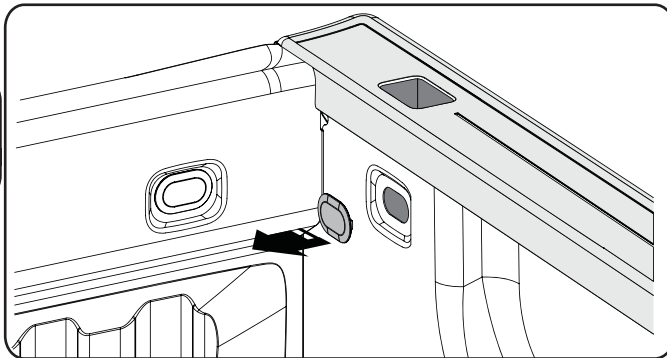

6 Remove and discard the plastic front side plugs from the Tub. Repeat for the opposite side.

FIG.7

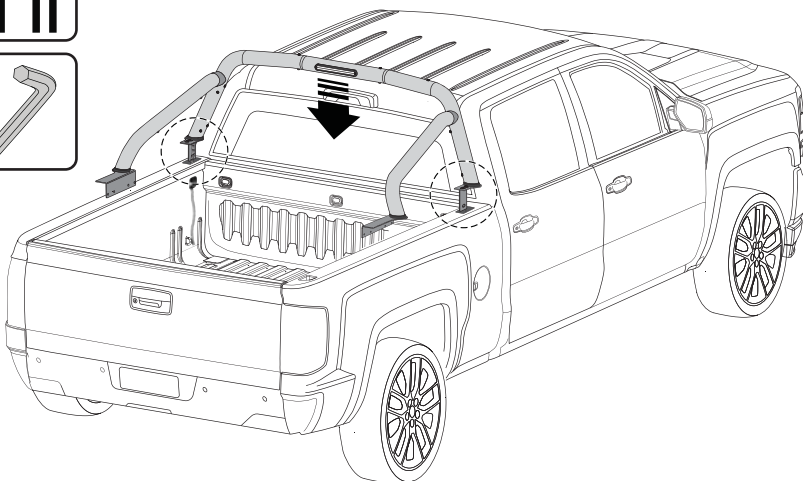
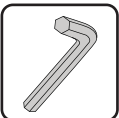

LEFT HAND SIDE SHOWN

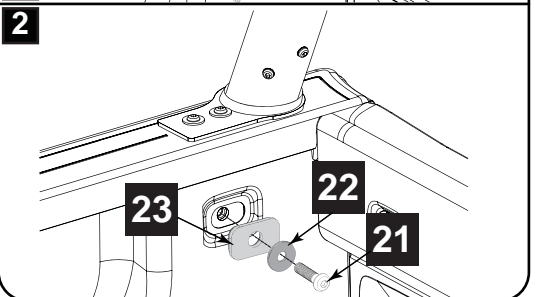
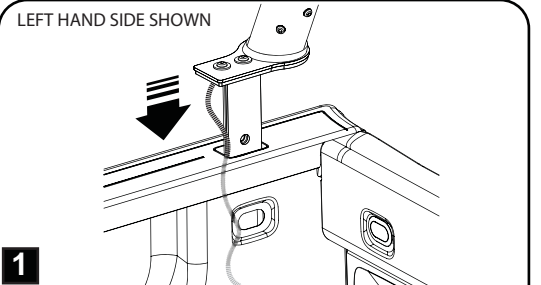

7 Using two people carefully lift the sports bar into position above the tub and insert the LED cable through the hole in the bed rail cap. Slowly follow by lowering the sports bar front foot through the bed rail hole and lower the sports bar assembly onto the tub of the vehicle. Loosely Secure the front foot to the tub using Screw(21), Washer(22) and Rectangular Washer (23). Repeat for the opposite side.

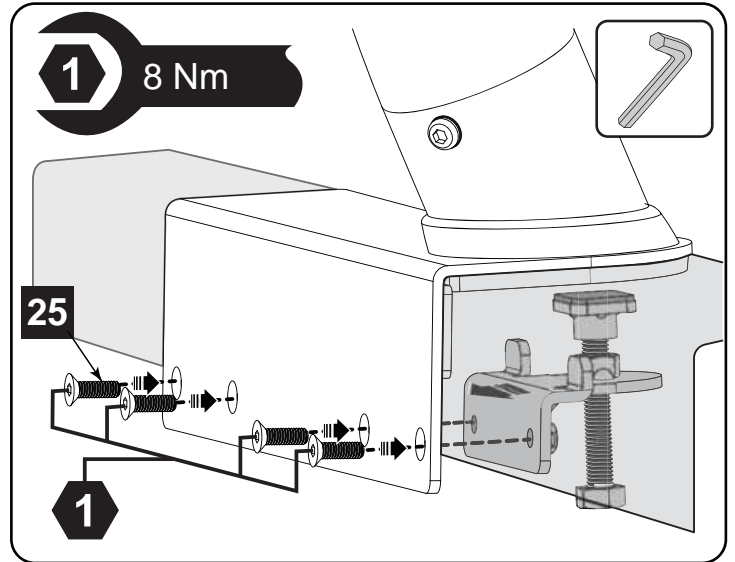
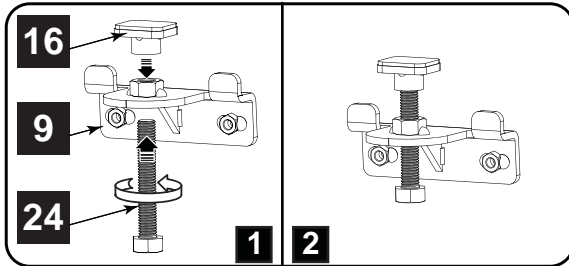
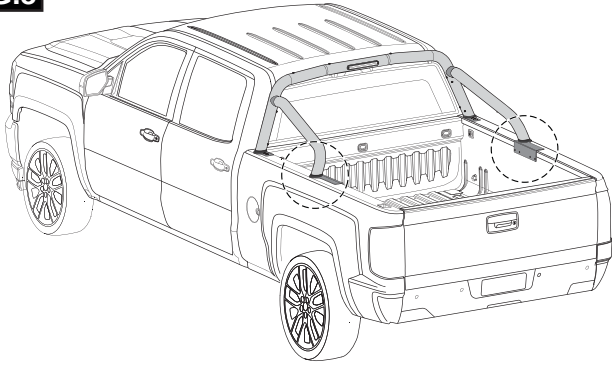
FIG.8

8 Assemble the rear foot clamp plates by screwing the Hex head bolts (24) into the clamp body (9) and attach the Screw Cap (16). Position the assembly on the inside of the tub and attach the Clamp Plate assemblies to the Rear foot of the sportsbar using screws 25. Repeat for the opposite side. Tighten the screws (25) to 8Nm using a Torque Wrench.

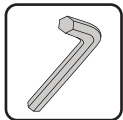
FIG.9

1 19 Nm

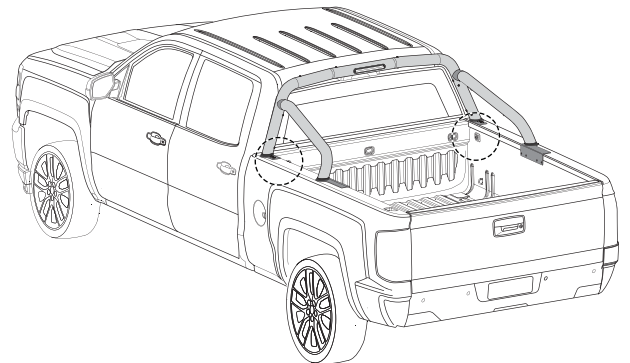
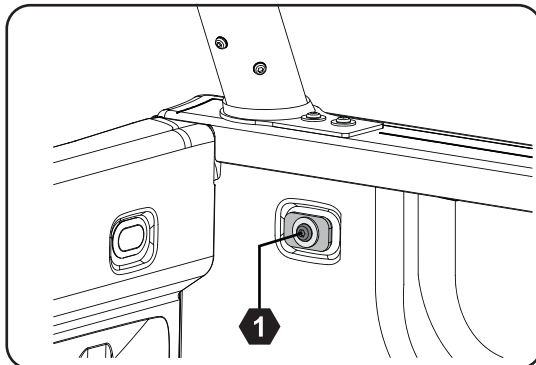

9 Tighten up the front screw (21) to a torque of 19Nm. Repeat for the opposite side.

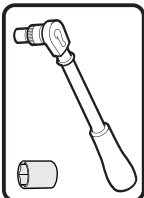
FIG.10

1 10 Nm

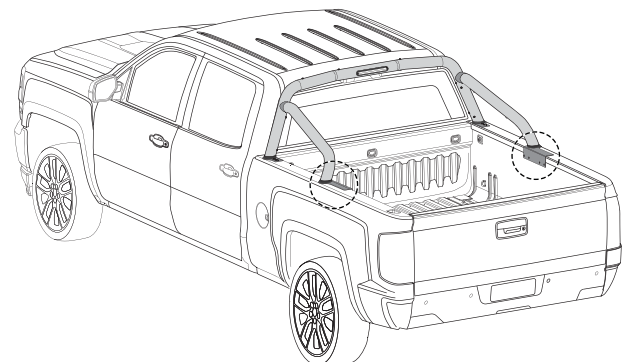
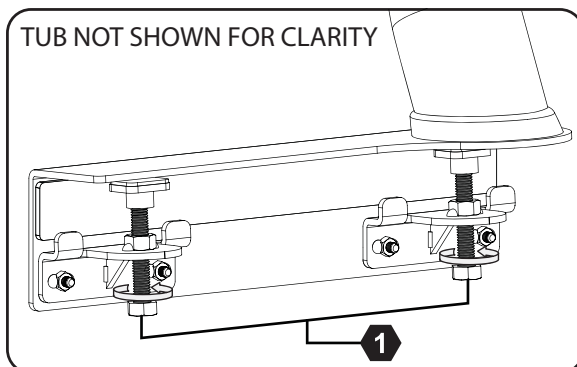

10 Tighten up the rear foot clamp plate bolts (24) to a torque of 10Nm. Repeat for the opposite side.

FIG.11

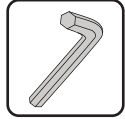

1 5 Nm

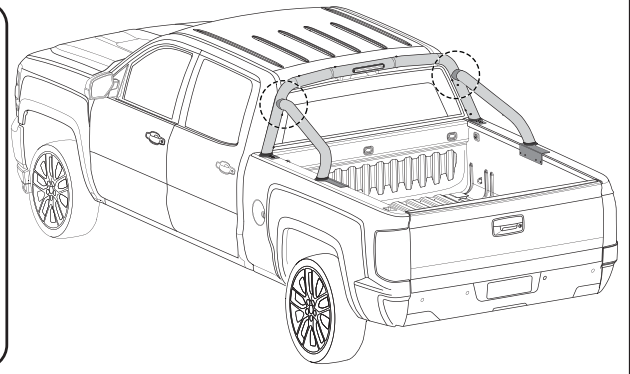
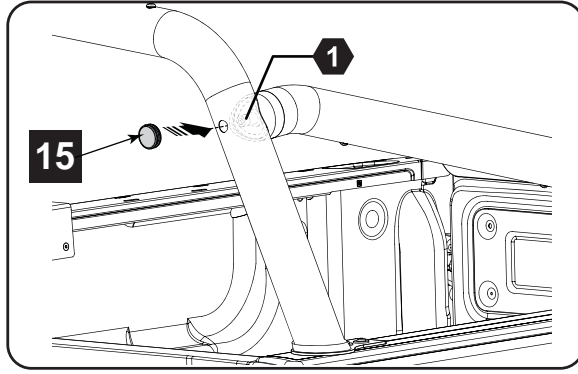

11 Align the joiner and tighten up the bolts which connect the front tube to the rear legs to a torque of 5Nm and insert a grommet (15) into the hole in the tube. Repeat for the opposite side.

FIG.12

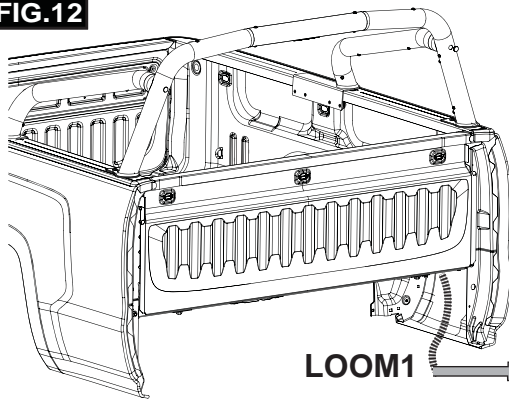

LOOM1

27



28

LOOM2

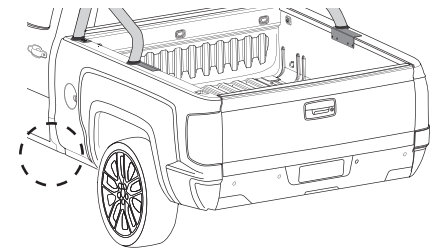

12 SBAR loom should drop under the vehicle behind the tub body work as shown. Underneath the vehicle connect LOOM1(27) with LOOM2 (28).

FIG.13

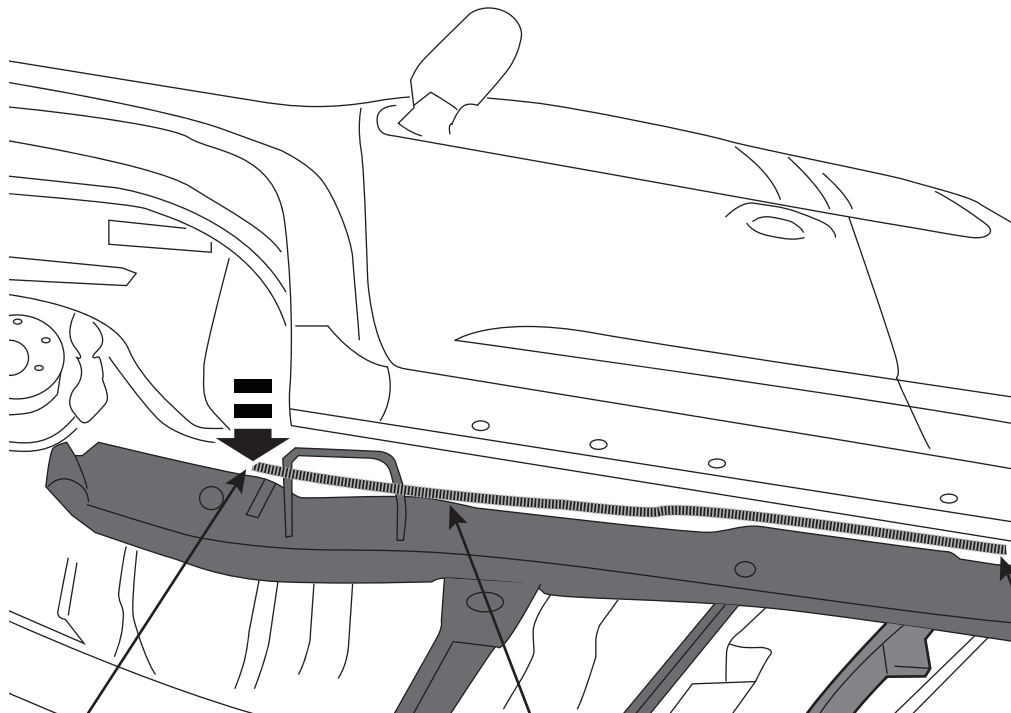

LOOM3

LOOM2

LOOM1

13 Route the loom 1 & 2 along the outboard side of the frame rail. Secure the loom using tags. Route the loom 3 to the fuel filler area of the pickup. Connect the loom 3 and loom 2.

FIG.14

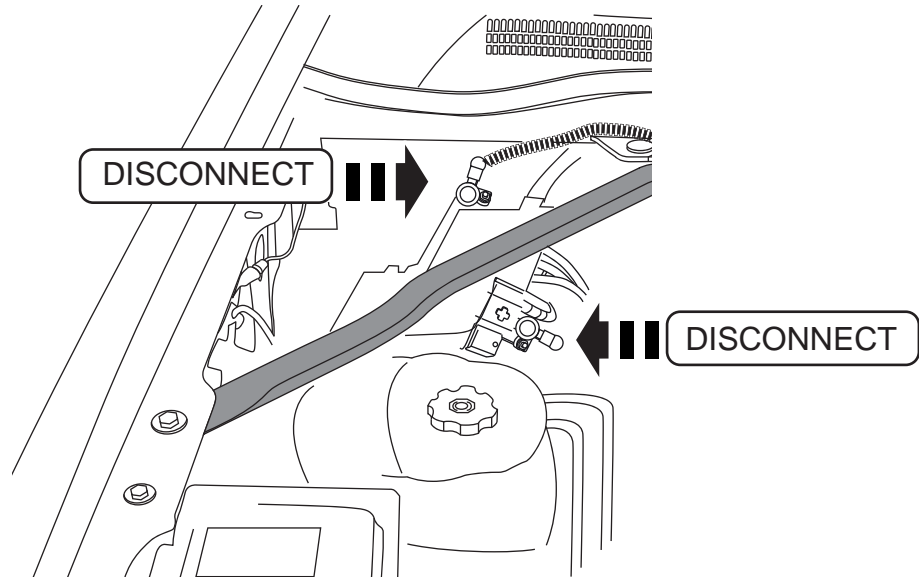
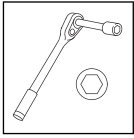

- 14** Remove the battery junction box lid.
Note: The wires from the battery need to be disconnected during those operations.

FIG.15

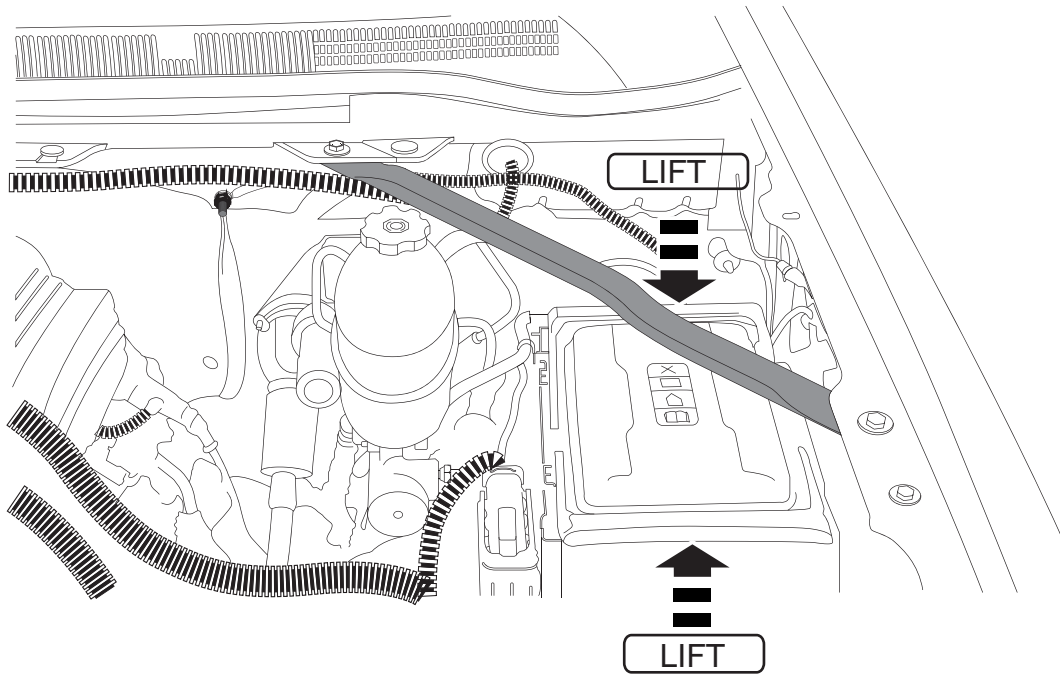

- 15** Unhook the top of the fuse box by pushing the 2 tabs on each sides of the release handle.

FIG.16

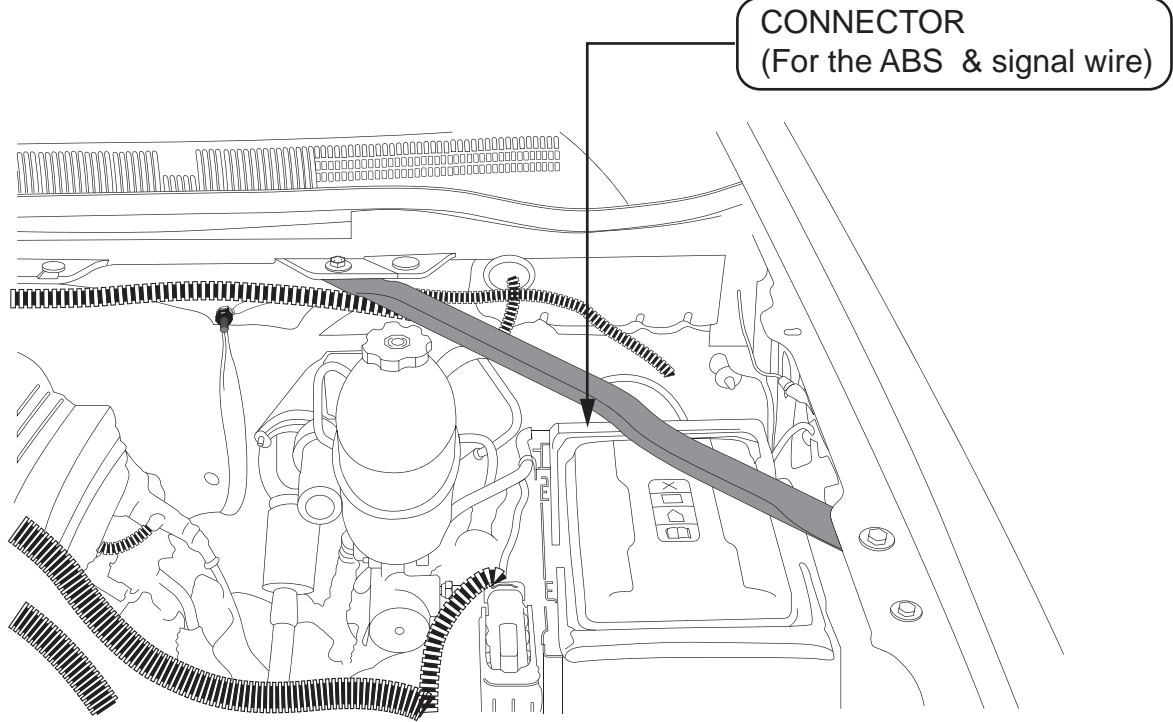

16 Unhook the connector for the ABS & signal wire (using screw driver) to gain access to the lower fuse panel.

FIG.17

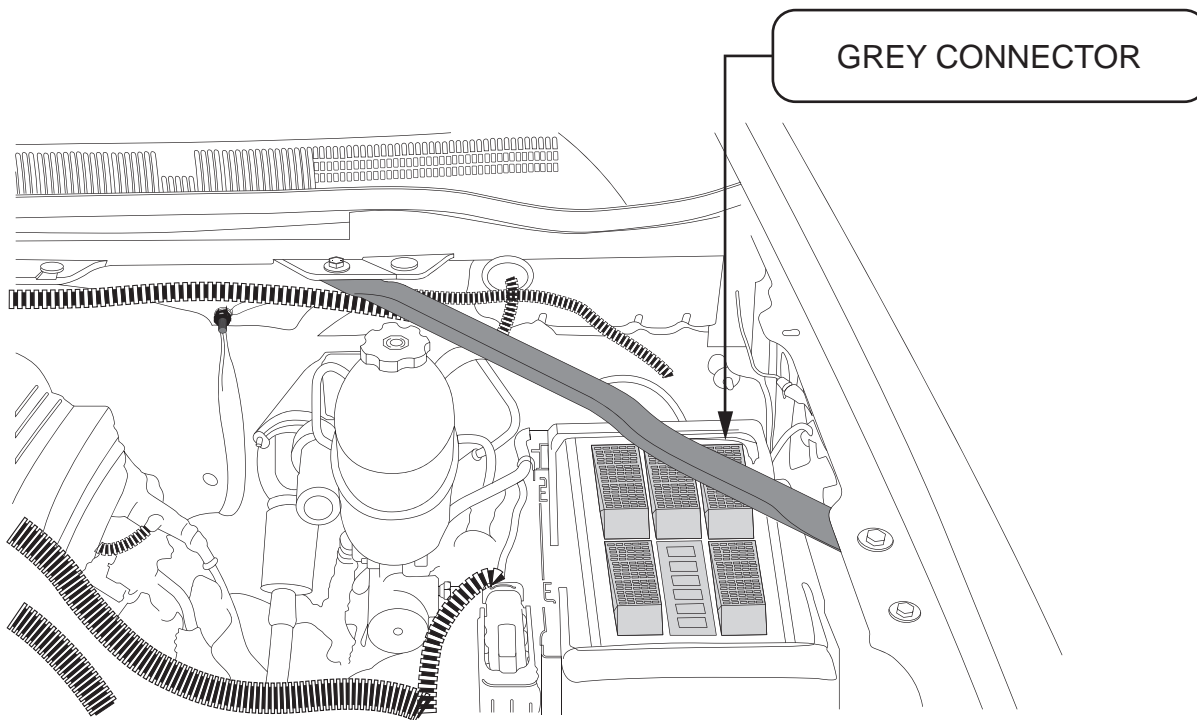

17 Remove the upper fuse panel. This is to gain access to the grey connector which is the outboard most connector to the back of the fuse panel.

FIG.18

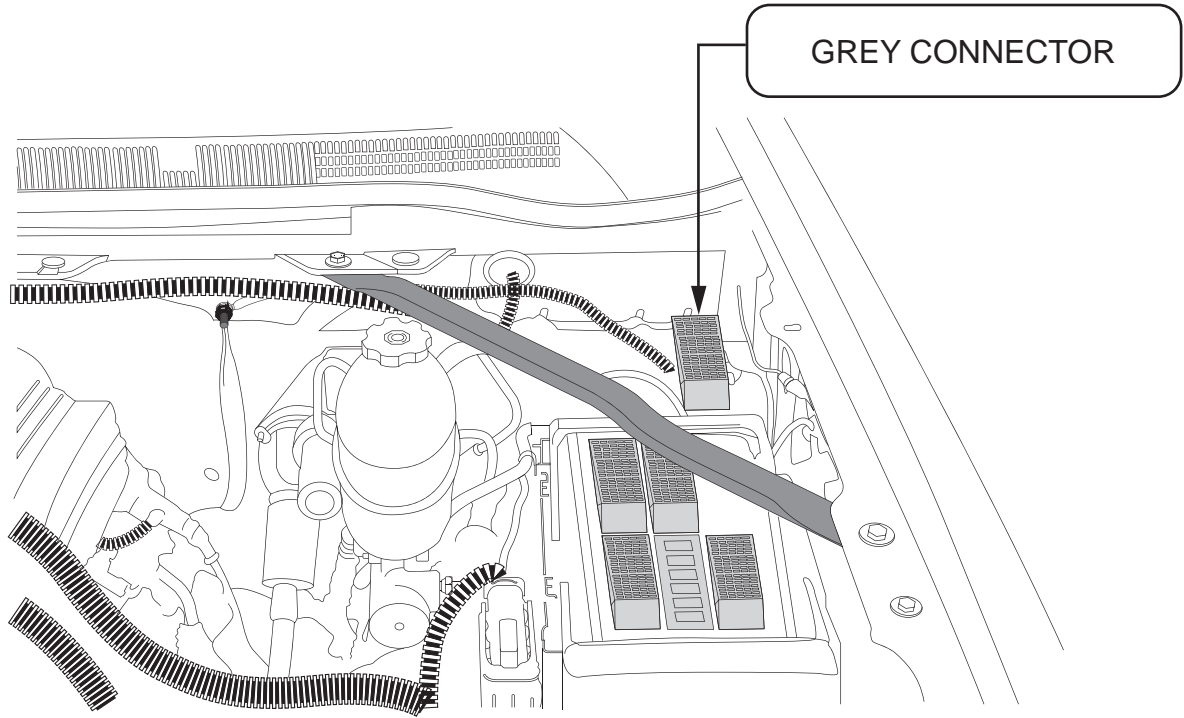

18 Release the grey connector by pushing the little tab at its bottom and pulling it back.

FIG.19

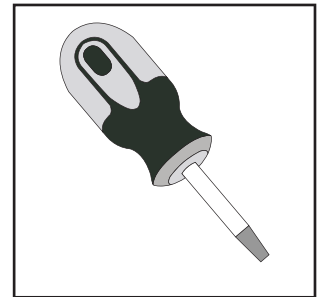
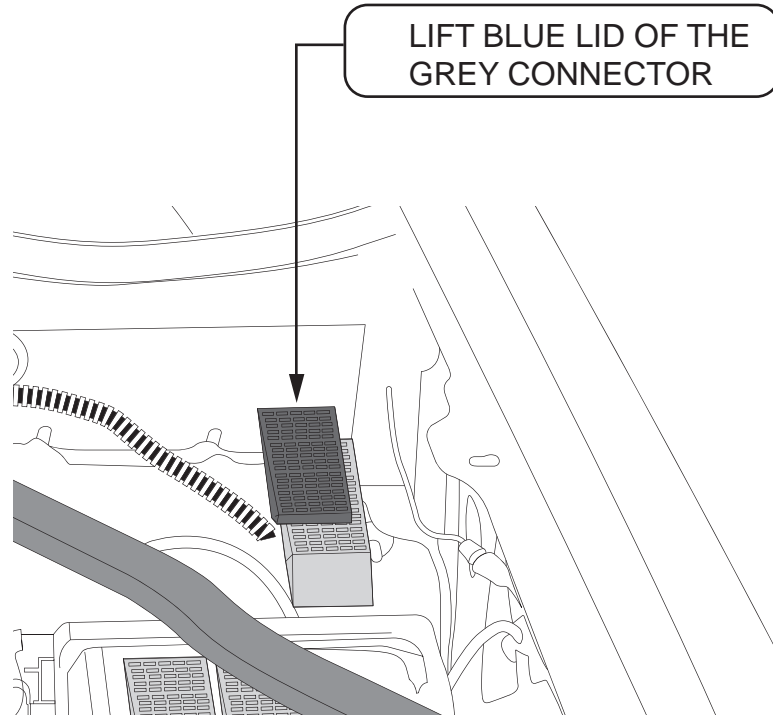

19 Remove the blue lid of the grey connector using a screw driver.

FIG.20

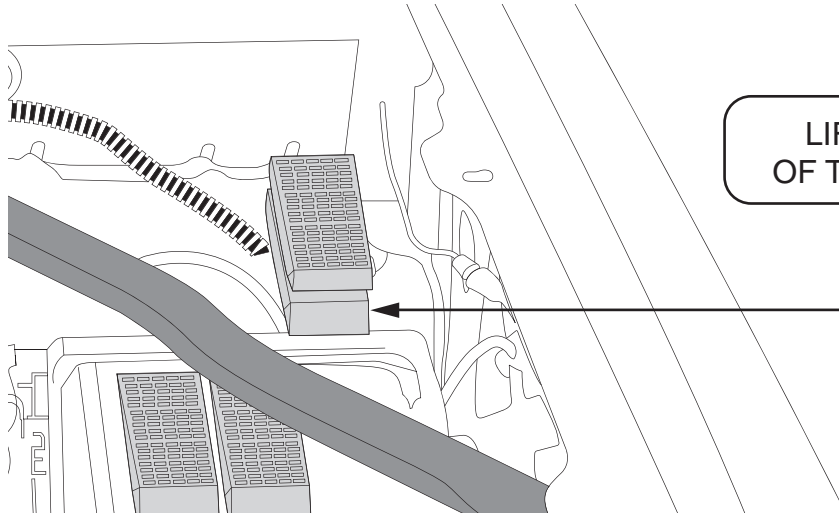
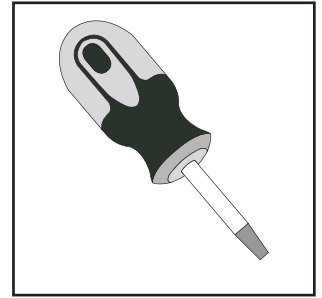

LIFT THE BACK COVER
OF THE GREY CONNECTOR

20 Unlock the back cover (back ledge) from the grey connector using a screw driver.

FIG.21

CAVITY M6

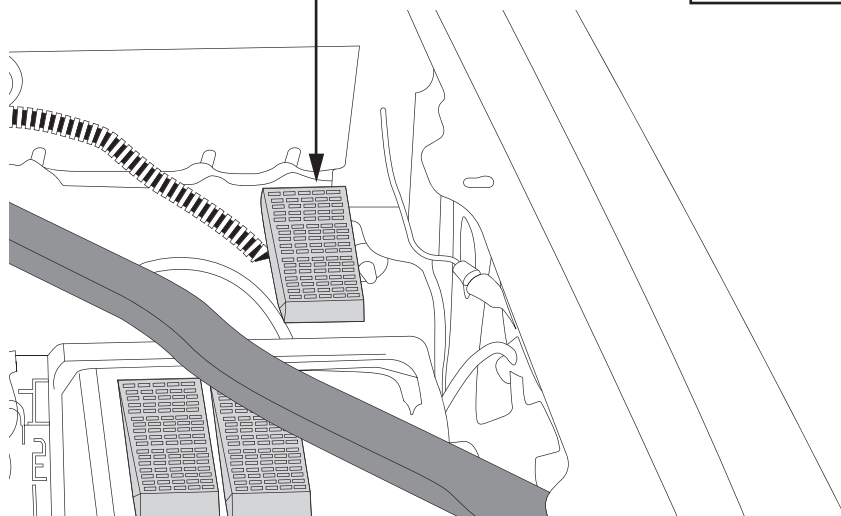
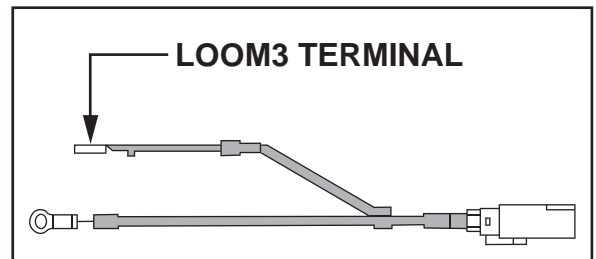

21 Locate the cavity "M6" (engraved on the connector). Connect the terminal of loom 3 into the cavity "M6".

FIG.22

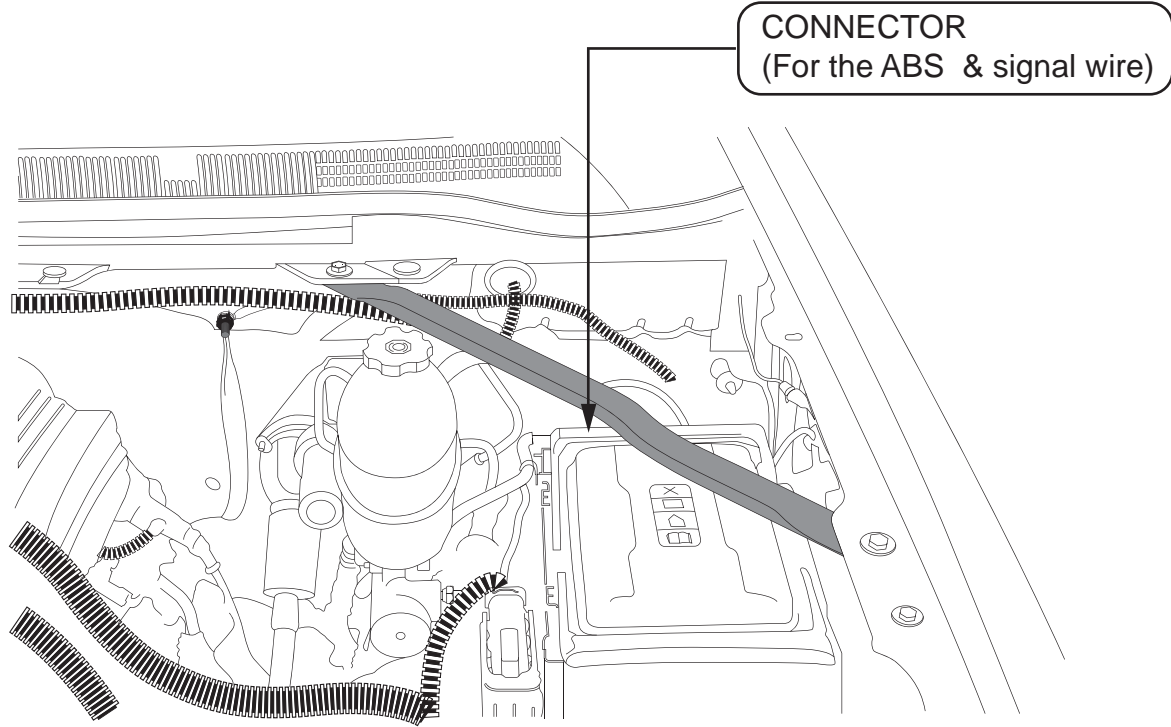

- 22** Reconnect the grey connector and the fuse panel. Follow reverse step 17 to 20. Take care that the loom 3 wires don't get pinched in between the panel while reconnecting. Reconnect the ABS & signal wire connector.

FIG.23

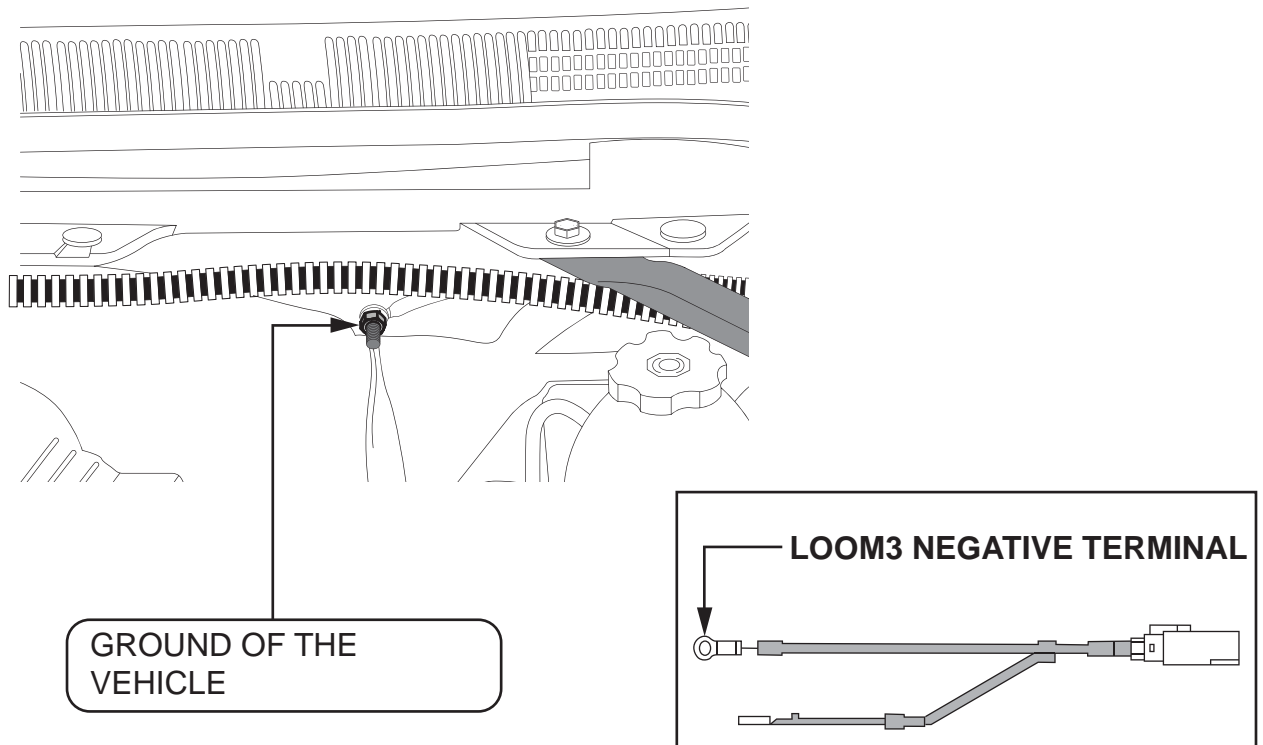

- 23** Reinstall the battery junction box lid. Connect the negative terminal (ring terminal) of loom 3 to the ground of the vehicle.
- Reconnect the battery wire and check whether the sports bar CHMSL is working when the brakes are engaged. Secure the excess wire length in the rear of the engine compartment and below the fuel filler area.