

# EAS

EXPANDABLE ACCESSORY SYSTEM

BACK-UP CAMERA



Monitoring device sold separately

## PARTS LIST

| ITEM | DESCRIPTION        | QTY    |
|------|--------------------|--------|
| ①    | CAMERA             | (1 EA) |
| ②    | BOLT               | (4 EA) |
| ③    | FLAT WASHER        | (4 EA) |
| ④    | LOCK WASHER        | (4 EA) |
| ⑤    | NUT                | (4 EA) |
| ⑥    | CABLE              | (1 EA) |
| ⑦    | SMALL FUSE ADAPTER | (1 EA) |
| ⑧    | LARGE FUSE ADAPTER | (1 EA) |
| ⑨    | 3M SEALANT TAPE    | (1 EA) |
| ⑩    | ZIP TIES           | (5 EA) |
| ⑪    | RCA ELBOW          | (1 EA) |
| ⑫    | CAMERA ADAPT.      | (1 EA) |

**REQUIRED TOOLS**  
 SCISSORS  
 ALLEN WRENCH (SUPPLIED)  
 3/8" WRENCH/SOCKET  
 1/4" DRILL BIT  
 POWER DRILL

(NOTE: The drill and drill bit may be needed in order to re-size the existing mount holes for bolt insertion. If the camera is ever removed, continue to use the supplied hardware to mount your licence plate.)

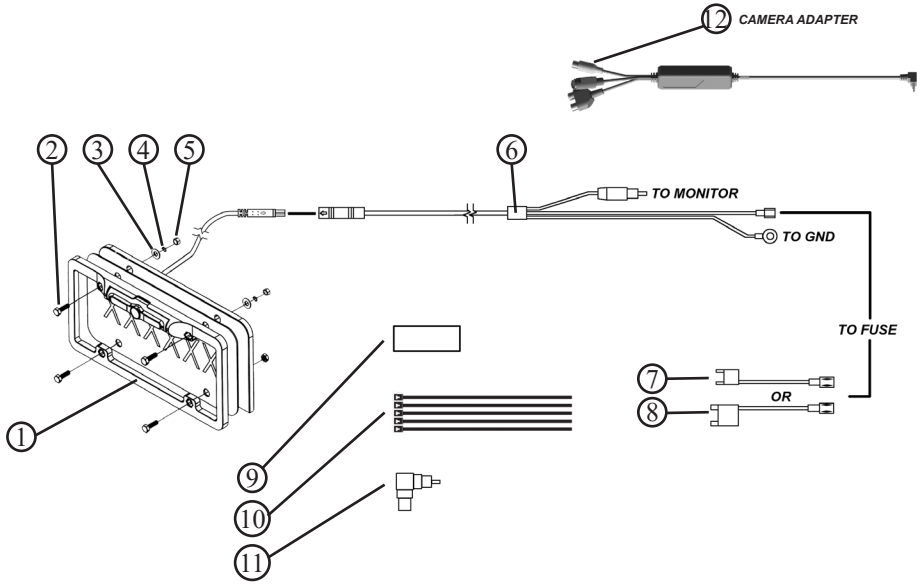

EXPLODED CAMERA ASSEMBLY

**MOUNTING THE CAMERA**

1. Remove the LICENSE PLATE from your vehicle and align it with the back side of the CAMERA as shown in the figure below.

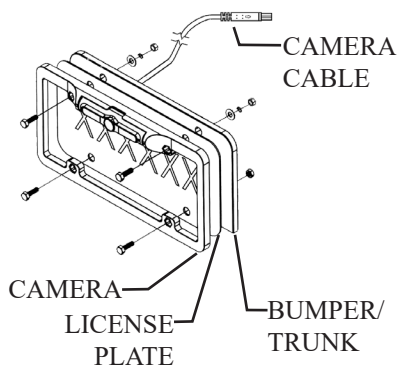

2. If an auxiliary hole exists behind the license plate, insert the CAMERA CABLE through it and make sure the connector is easily accessible for routing.

3. Align the CAMERA and LICENSE PLATE with the bumper/trunk holes and insert the (4) bolts.

5. With the bolt in place, slide the FLAT WASHER and LOCK WASHER over the backside of the bolt and fasten with a nut.

6. Tighten until snug.

**SEALING THE CABLE**

1. Plug the CABLE into the CAMERA CABLE as shown.

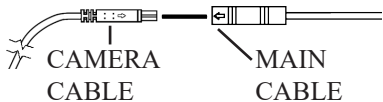

2. Trim one end of the 3M SEALANT TAPE as shown.

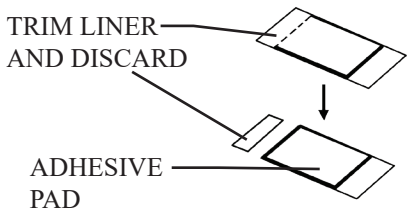

3. Wrap the seam on the connection made in step 1 to improve the seal.

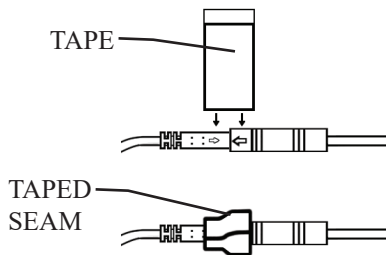

4. Firmly press/squeeze the wrapped tape to create the best seal and adhesion possible.

## ROUTING THE MAIN CABLE

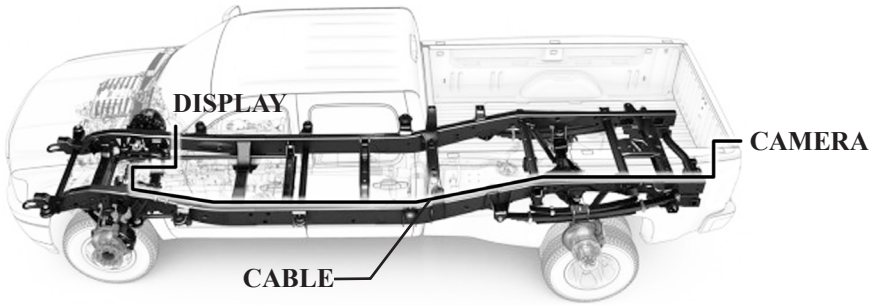

1. Route the CABLE along the frame of the vehicle. Use the ZIP-TIES to secure the cable.

2. Locate an existing point of entry into the vehicle interior along the fire wall.

Avoid routing near:  
 -Hot surfaces such as exhaust components.  
 -Moving parts such as suspension.

3. Route the CABLE through the fire wall and into the cab.

## IN-CAB & FUSE CONNECTIONS

1A. Route the RCA cable up the side of the driver side dash, and plug it into the Monitor.

Monitor, then the cable into the adapter. This will allow the connector to sit tight against the inside of the pod adapter and eliminate interference with your dash.

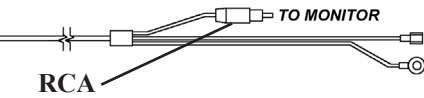

*(NOTE: If you own a dash pod, you may need to use the right angle adapter for a lower profile fit. See step 1B)*

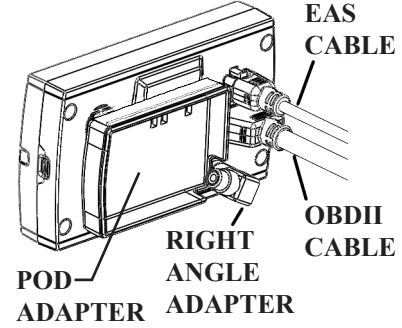

1B. Plug the RIGHT ANGLE ADAPTER into the back of the

NOTE: If you own a Monitor with no RCA plug/connector, a camera adapter is required to use the back-up camera. (1C)

1C. Plug in the camera's cable into the adapter, and then plug in the adapter's Mini USB into the Monitor's Mini USB plug.

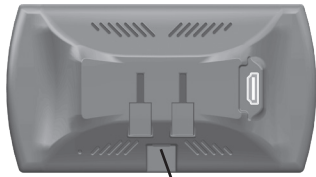

Mini USB

2. Next, route the GROUND lug to any grounded connection and fasten in place using existing hardware.



3. Route the POWER connection to your fuse box. (Your fuse box may be under the hood of your vehicle)

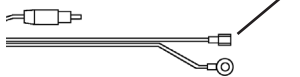

4. In your fuse box, locate a 10 amp fuse that is powered only when your key is turned on. This information can be found in your vehicle's user manual.

**(CAUTION: Do not connect to a Fuse location that has con-**

**stantly supplied power. Doing so will drain your battery.)**

5. Remove the fuse, turn your key on, and determine which side of the fuse location is supplied with power (known as the "Hot" side). *A voltage meter or test light may be used.*

6. Turn the key off. Retest the fuse location to make sure the power was shut off when you turned your key off.

7. Locate the proper 10 amp FUSE ADAPTER provided in your kit. The leg with the wire soldered to it needs to be placed in the "HOT" side of the fuse location (determined in step 6).

8. Plug the POWER connector into the FUSE ADAPTER connector.

9. Plug the RCA connector into the backside of your Monitor.

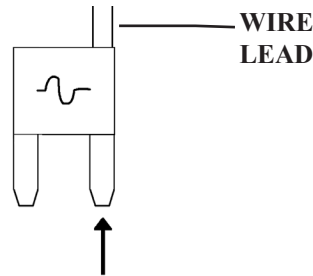

KEYED POWER (HOT SIDE IN FUSE BOX)

**U S I N G   Y O U R   C A M E R A****VIEW THE CAMERA  
IMAGE ON YOUR Monitor**

1. Power your Monitor.
2. Touch the MAIN MENU icon on the main gauge screen.
3. Touch the View Camera option from the list. Your camera image should appear.

**ADJUST THE VIEW ANGLE**

1. Use the supplied ALLEN WRENCH to loosen the camera lens set screws.
2. Adjust the view up or down, and re-tighten the set screws.

**S A F E T Y****IMPORTANT SAFETY INFORMATION**

**This device should be used as a secondary aid while driving your vehicle and should never be used as the sole source of position information. You must always look behind , to the sides, and use your mirrors to assist you.**

**!WARNING!**

**Misuse of this product could lead to injury or death. Obey all traffic laws. Read and comply with all information in the Monitor/Tool's User Guide included with that product.**