



INSTALLATION INSTRUCTIONS

DESCRIPTION: Edelbrock offers several valve covers for several engine models. See catalog for application listing. Installation is the same as original equipment valve covers. Aluminum models are available in various finishes including EnduraShine™ and PermaStar®. All aluminum covers require that baffles be installed if breathers are used. Some racing valve covers require that holes be machined for breathers if breathers are desired. Signature Series valve covers include baffles. Check for clearance between baffles and rocker arms. Trim baffles slightly if necessary.

INSTALLATION NOTES FOR ALUMINUM VALVE COVERS (4100 & 4200 SERIES PART NUMBERS):

- For applications using breathers/PCV, attach the breather baffles using the supplied drive pins. Using a punch and hammer, tap pins in until fully seated (**See Fig. 1**). On valve covers without breather holes, the breather holes must be drilled/machined before attaching the baffles.

CAUTION! WHEN DRIVING THE PINS INTO THE VALVE COVER, YOU MUST SUPPORT THE BACK SIDE OF THE VALVE COVER WITH A BLOCK OF WOOD, OR OTHER NON-MARRING SURFACE. FAILURE TO DO SO COULD RESULT IN DAMAGE TO THE COVER, SUCH AS CRACKS, DENTS, ETC. (**See Fig. 1**).

Recessed Baffles: Some valve covers include baffles with a curved recess across them. Make note of the position of the baffle. The recess in the baffle plate should be positioned as shown below (**See Fig. 2**).

- **Breather Knockouts:** Centerbolt covers are intended for use with OEM breather and PCV valve. If the application calls for non-OEM push-in breathers, remove the “knockout ring” from the breather holes using a hammer and a large punch. Be sure to support the perimeter of the breather hole with a large socket, or block of wood. Perform this procedure BEFORE installing the breather baffles.
- **Pontiac:** Elite Valve Covers #4256 for Pontiac V8s will require that spacers be used to provide clearance for the A/C compressor bracket. Install the spacers under the bracket at the intake manifold.
- **Small Block Chevrolet:** 1986 and earlier Small block Chevrolet engines with EGR may require #1476 and/or GM #14031368 spacers to provide clearance for the EGR valve, especially with “tall profile” valve covers.

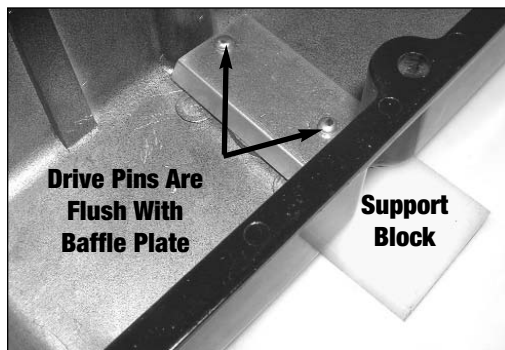

Fig 1. - Baffle Plate Installation
Support the back of the valve cover while tapping drive pins into place.

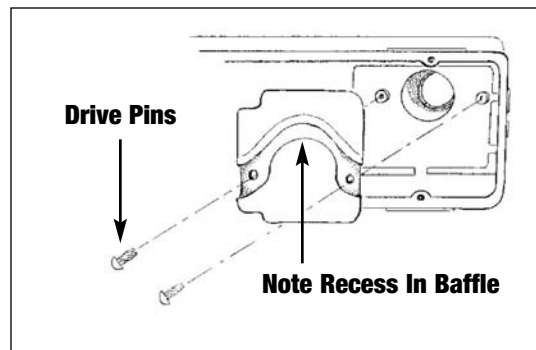

Fig. 2 - Recessed Baffle Installation
Make sure recess faces out, and the curved portion faces towards the side closest to the intake manifold.