



## **Edelbrock E-Force Supercharger**

**2013-14 SCION FR-S / SUBARU BR-Z 2.0L**

**Part #1556 and 15560**





## Edelbrock E-Force Supercharger System 2013-14 BR-Z/FR-S 2.0L

### Installation Instructions

---

#### INTRODUCTION

Thank you for purchasing the Edelbrock Supercharger System for the Scion FR-S and Subaru BR-Z with 2.0L horizontal four. This is a front drive, front inlet, inverted supercharger system using Eaton's TVS1320 rotor group. The supercharger housing features an integrated dual pass intercooler measuring in at 10" long by 7" wide and 1.5" thick.

#### TOOLS AND SUPPLIES REQUIRED

- Jack and Jack Stands or Service Lift
- 50/50 Coolant Mixture: ~1.5 Gallons
- Brake Fluid - FMVSS No. 116 DOT3, or equivalent (Manual Applications Only)
- Ratchet and Socket Set including but not limited to:
  - 1/4 Drive: 8mm, 10mm and Universal Joint
  - 3/8 Drive: 8mm, 10mm, 12mm, 14mm, 17mm
- Wrench Set including but not limited to: 8mm, 10mm, 12mm, 14mm, 17mm
- Breaker Bar: 1/2"
- Subaru Fuel Line Removal Tool #42099AE000, or equivalent
- Rivet Nut Tool, or equivalent.
- Utility Knife
- Spill-Free Funnel
- Panel Puller
- Flat Blade & Phillips Screwdrivers
- Side Cutters
- Torque Wrench
- Pliers or Hose Clamp Removal Tool
- Blue Thread Locker - *(It is generally recommended to apply BLUE thread locker, unless specified, onto the threads of all bolts prior to installing.)*
- O-ring Lube
- Masking Tape
- Shop Rags
- Wire Ties

### INSTALLATION HARDWARE IDENTIFICATION GUIDE

(Parts Are Not To Scale)

BAG #1 - FEAD HARDWARE				
Item	P/N	QTY.	Description	Torque Spec
1	36-0183	1	Bolt, Hex, M8 x 170mm	18 Ft-lbs
2	36-0186	1	Bolt, Hex Flange, M10 x 70mm	22 Ft-lbs
3	36-0187	2	Bolt, Button Head, M6 x 12mm	6 Ft-lbs
4	12-3213	1	Washer, 8.5mm	N/A

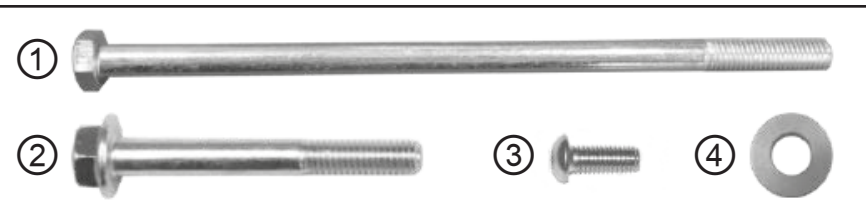

BAG #2 - INTERCOOLER HARDWARE				
Item	P/N	QTY.	Description	Torque Spec
1	46-2155	8	3/4" Hose Clamp	N/A
2	36-1552	4	Bolt, Hex Flange, M6 x 10mm	N/A
3	36-0173	1	Bolt, Hex Flange, M5 x 20mm	N/A
4	36-8553	1	M5 x 0.8 Rivet Nut	N/A
5	46-2181	1	Zip Tie, Push Mount	N/A

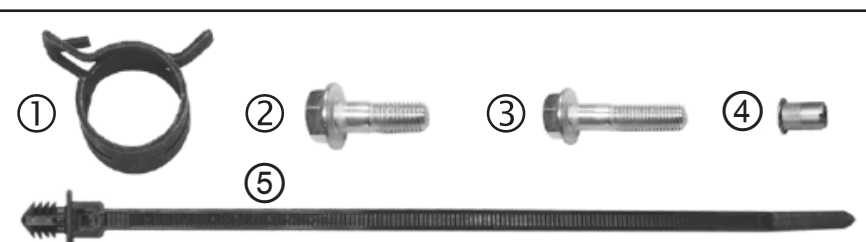

BAG #3 - MANIFOLD/RUNNER HARDWARE & FUEL FITTING				
Item	P/N	QTY.	Description	Torque Spec
1	36-1518	4	Bolt, Hex Flange, M8 x 30mm	10 Ft-lbs
2	36-4040	2	Bolt, Hex Flange, M8 x 50mm	10 Ft-lbs
3	87-0270	2	Crush Washer, 12mm, Alum.	N/A
4	12-3216	1	Washer, Black-Oxide Steel	N/A
5	12-3212	2	Crush Washer, 10mm, Alum.	N/A
6	88-0645Z	1	Fuel Fitting, 12mm Banjo	N/A

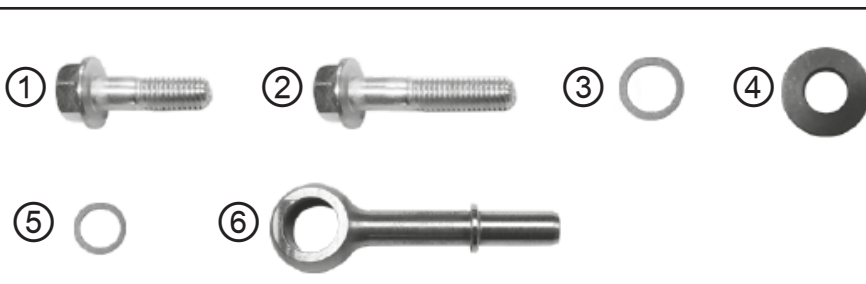

BAG #4 - AIR INTAKE HARDWARE				
Item	P/N	QTY.	Description	Torque Spec
1	88-0624	1	Fitting, 1/2" barb to 1/2" barb	N/A
2	36-8900	1	Isolator, Neoprene	N/A
3	46-4183	1	3/4" Hose Clamp	N/A
4	46-2182	6	5/8" Hose Clamp	N/A
5	64-1556	1	Plug, Sheet Metal, Plastic, 1"	N/A
6	51-4223	1	MAF Sensor O-Ring	N/A
7	72-1542	1	Grommet, 1/2" Hole	N/A
8	72-1541	2	Grommet, 5/16" Hole	N/A
9	12-3211	9	Washer, Flat, 5/8"	N/A
10	36-0187	12	Bolt, Button Head, M6 x 12mm	1.5 Ft-Lbs
11	36-0182	2	Bolt, Button Head, M4 x 10mm	1.5 Ft-Lbs
12	36-0185	1	Bolt, Button Head Flanged, M5 x 8mm	1 Ft-Lbs
13	72-1540	2	Grommet Sleeve	N/A
14	60-1508	1	Nut, M6, Locknut	1.5 Ft-Lbs

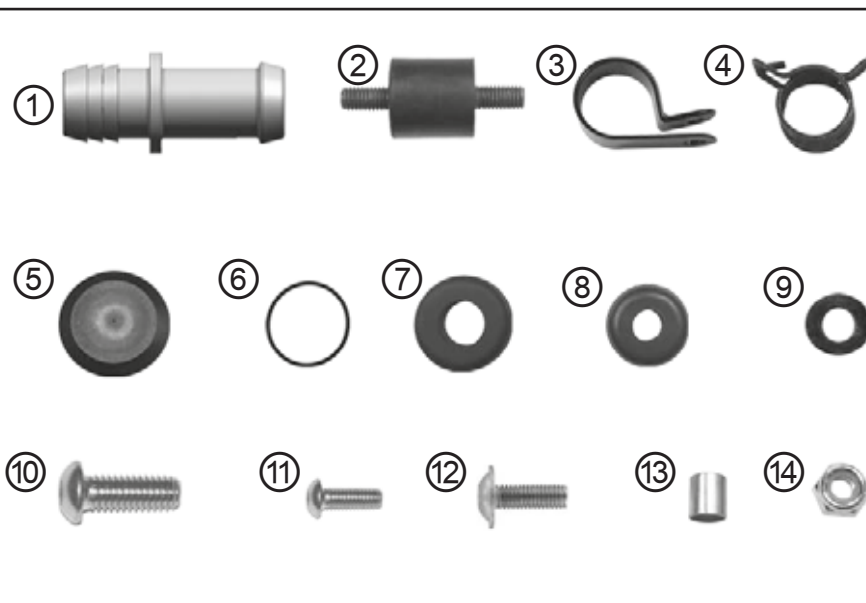

**BRACKET AND FEAD IDENTIFICATION GUIDE**

*(Parts Are Not To Scale)*

BRACKET AND FEAD			
Item	P/N	QTY.	Description
1	38-0160	1	Water Pump Bracket
2	38-0161	1	Surge Tank Bracket
3	24-15564	1	FEAD Bracket
4	38-0167	1	LH PCV Support Bracket
5	38-0162	1	Airbox Bracket
6	38-0163	1	Lower Airbox Support Bracket
7	38-0165	1	Nose Support Plate
8	38-0164	1	EVAP Bracket



### HOSE IDENTIFICATION GUIDE

(Parts Are Not To Scale)

INTERCOOLER/LTR HOSES			
Item	P/N	QTY.	Description
1	51-4242	1	IC to Surge Tank Hose
2	56-1535	1.5 Ft	3/8" Vacuum Hose
3	51-4243	1	Surge Tank to W/P Hose
4	51-4240	1	W/P to LTR Hose
5	51-4241	1	LTR to IC Hose

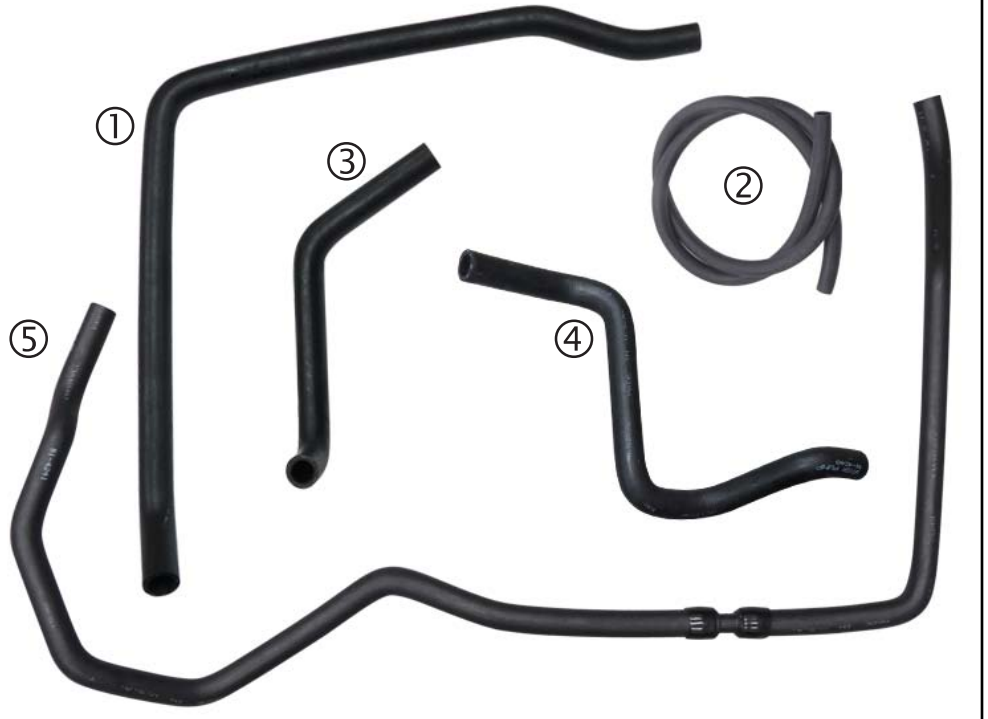

VACUUM / THROTTLE BODY HEATER HOSES			
Item	P/N	QTY.	Description
1	51-4244	1	TB Inlet Hose
2	51-4245	1	TB Outlet Hose
3	51-4246	1	RH PCV Hose
4	51-4248	1	Brake Booster Hose
5	56-1600	1	29" 5/16" EVAP Hose
6	56-1600	1	EVAP Hose w/ 45° Quick Connect
7	51-4247	1	LH PCV Hose

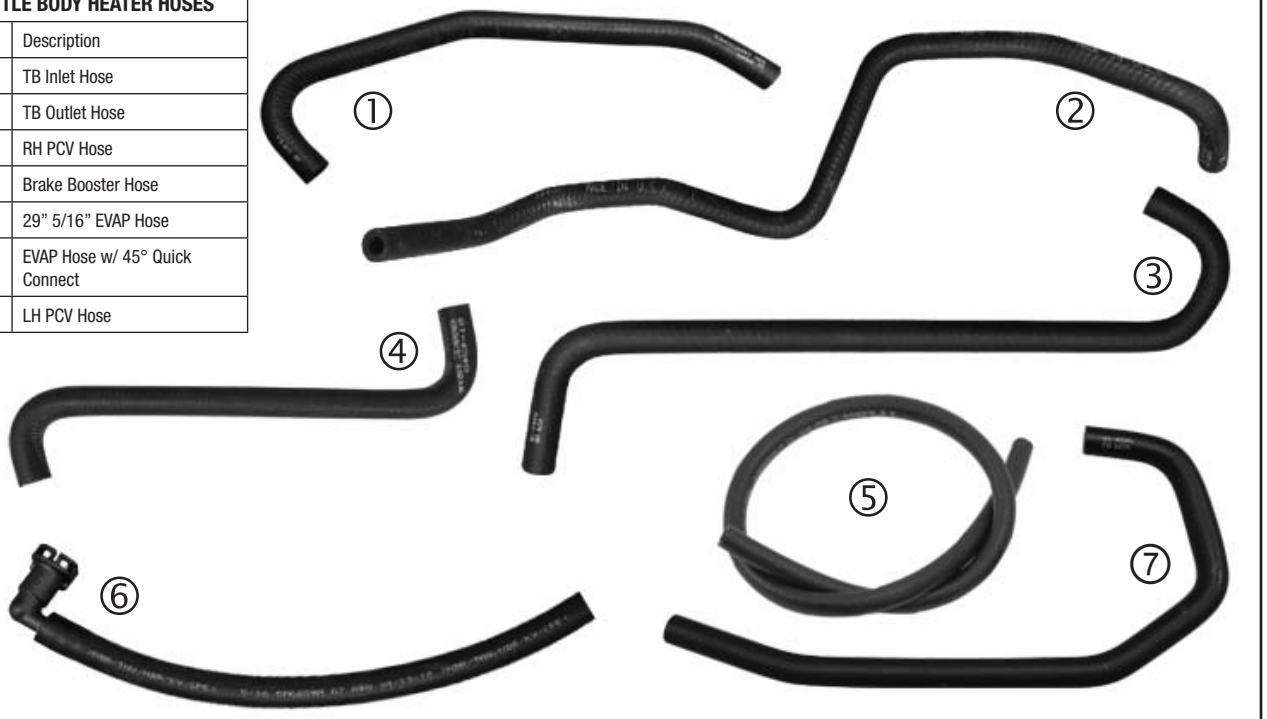

**HOSE ROUTING DIAGRAM**

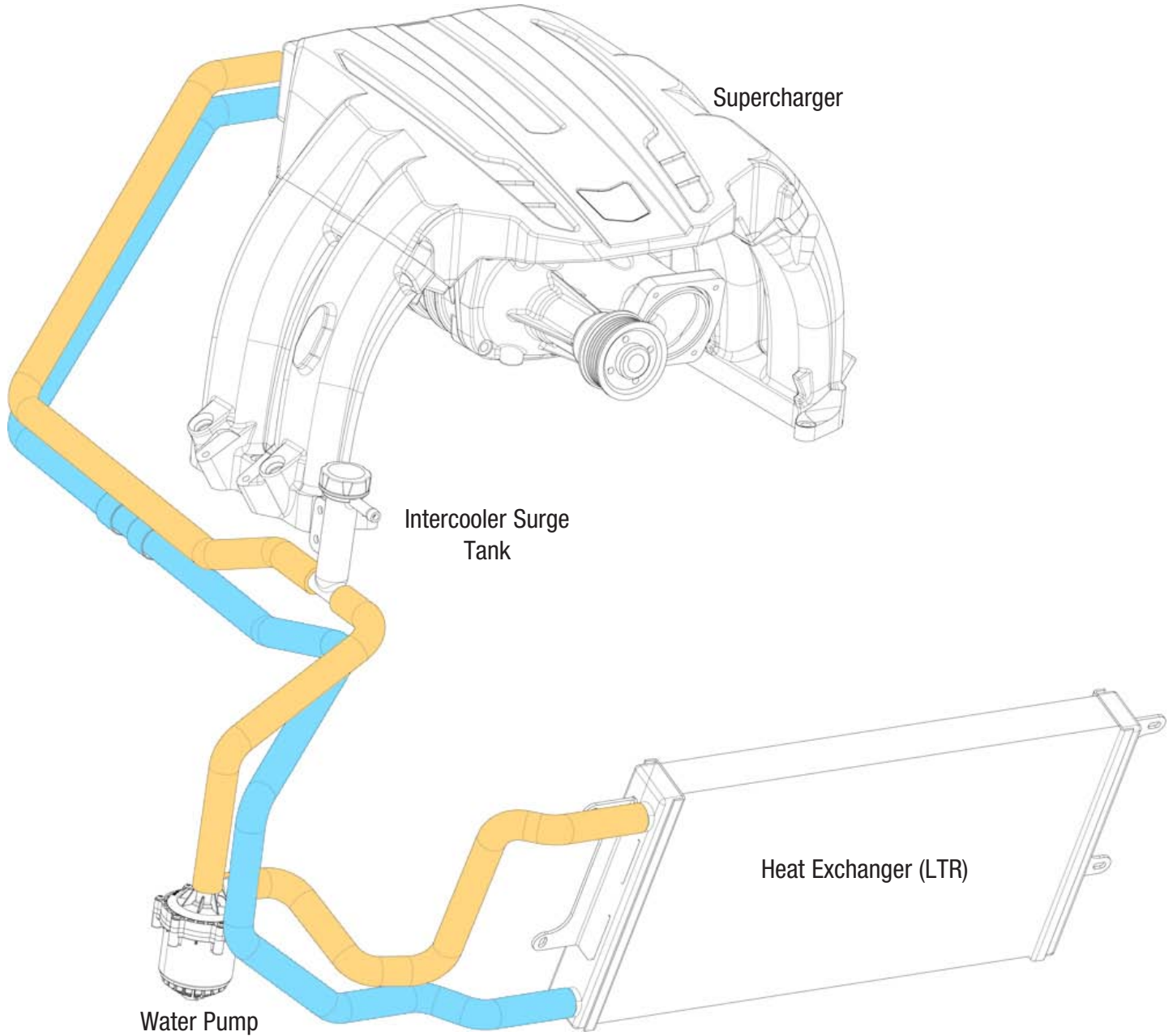

### WIRE HARNESS GUIDE

*(Parts Are Not To Scale)*

HARNESSES			
Item	P/N	QTY.	Description
1	37-1572	1	WP Harness
2	37-1571	1	TB Extension Harness
3	37-1570	1	TMAP Harness

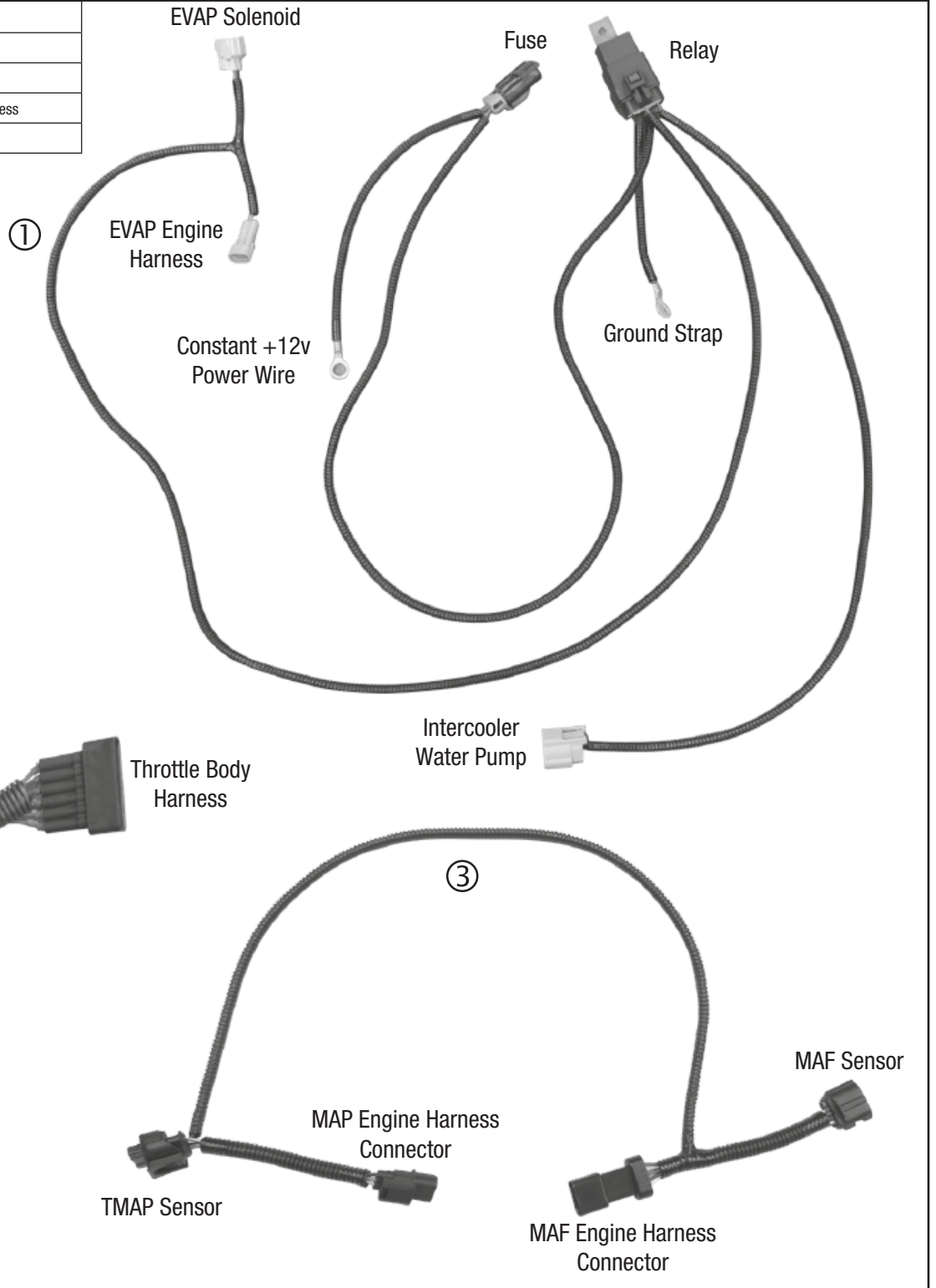



# Edelbrock E-Force Supercharger System 2013-14 BR-Z/FR-S 2.0L

## Installation Instructions

### PRE SUPERCHARGER INSTALLATION

Before starting the supercharger installation, it's highly recommended to remove any fuel pressure present within the fuel lines.

To do so, remove the 20A Fuel Pump (F/PMP) fuse from the fuse box and start the engine. Let the engine idle until it stalls. *NOTE: If the engine is cold, there may not be enough fuel pressure present to start the engine. If this is the case, continue with the removal of the fuel pump fuse regardless.*

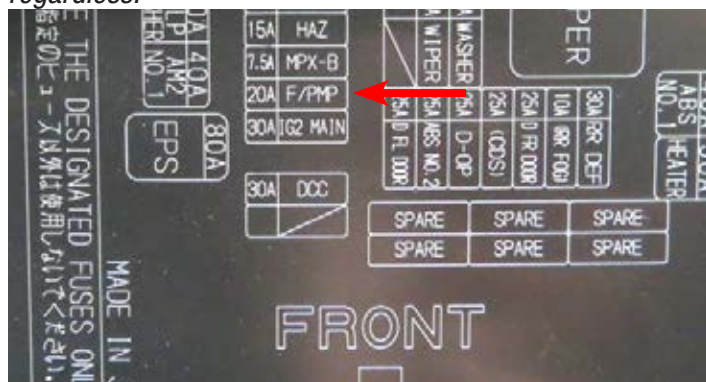

### REFLASHING THE ECU

**NOTE:** To prevent vehicle downtime, it is highly recommended to verify that your vehicles' ECU is supported by the EcuTek components included with your E-Force supercharger system (complete systems only). Prior to starting the supercharger installation, download and install the free EcuTek software to a laptop computer (recommended).

1. Download the EcuTek application.
2. Select "EcuTek App Downloader" and save the installer file to your computer.

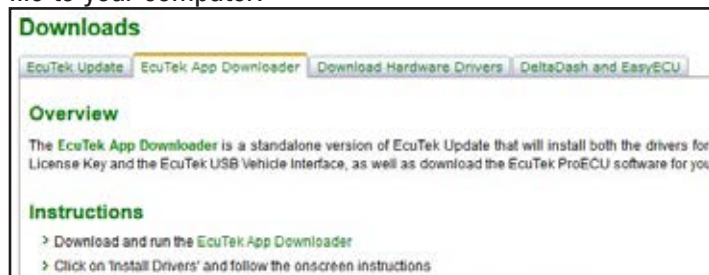

3. Open the installer file to run the application. Select Next to continue.

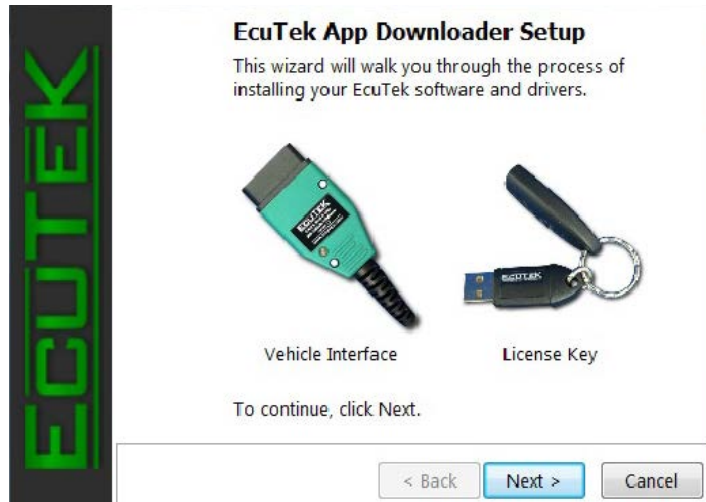

4. You will be prompted to install the necessary EcuTek software and drivers. It is also recommended to install Adobe Reader if you currently do not have it installed. Select Next to continue.

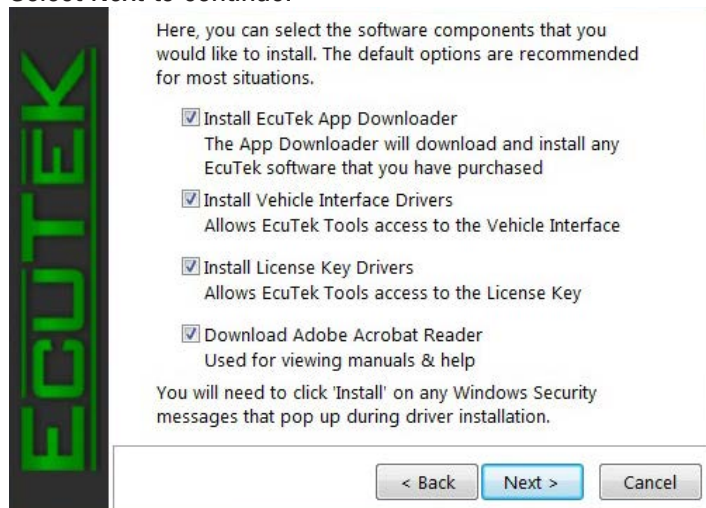

5. Agree with the Windows security warnings if they appear and select Install to continue.



### Installation Instructions

6. Plug the vehicle interface cable into the laptop when prompted to do so. Select Next to continue.



7. Insert the license key and select Next to continue.

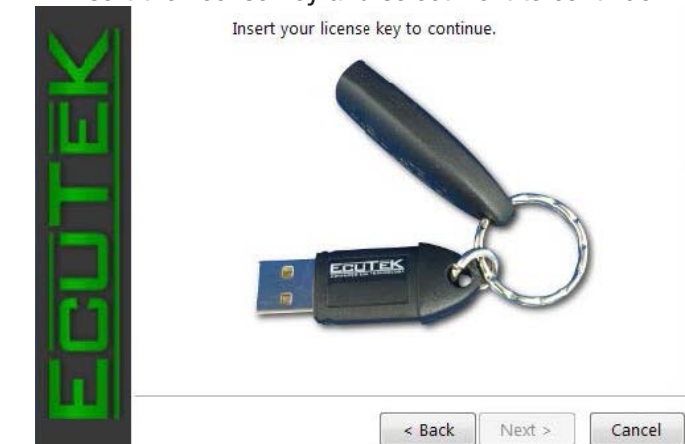

8. Installation is now complete. Verify Run ECUTek APP Downloader is checked and select Finish to complete the process.

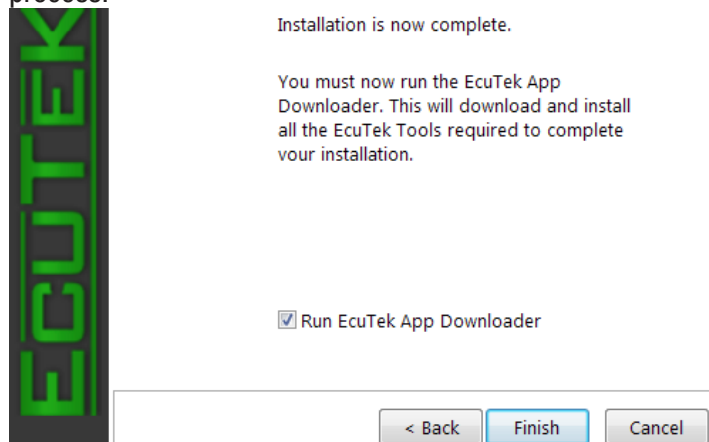

9. Make note of the Dongle ID and the Registration Code. Keep this information safe, for future reference. Select Download Now.



10. The download process may take a few minutes, so please be patient. When the download has completed, select OK to continue. Installation of the EcuTek ProECU software is now complete.

*NOTE: When programming the ECU, it's highly recommended that all non-essential vehicle devices are switched off before attempting to program an ECU. This includes: headlights, interior lights, A/C, HVAC fan, radios and any other powered devices.*

11. Plug the laptop into a power source.

12. Insert the supplied USB flash drive into the laptop.

13. Copy and save all of the provided files located on the flash drive onto your computer in the following folder location: C:\EcuTek\ProECURomFiles\Subaru\BRZ.

14. Plug the EcuTek OBD2 vehicle interface cable into the vehicles OBD2 diagnostic socket. The socket is located beneath the lower section of the dashboard just above the drivers throttle pedal.

15. Connect the other end of the EcuTek vehicle interface cable to a USB port on the laptop computer.

16. 'Key-On' the vehicle ignition by pressing the start button twice WITHOUT stepping on the brake pedal. DO NOT START the engine.



## Edelbrock E-Force Supercharger System 2013-14 BR-Z/FR-S 2.0L

### Installation Instructions

17. In the ProECU software menu bar, select 'Tools', then 'Detect Vehicle'.

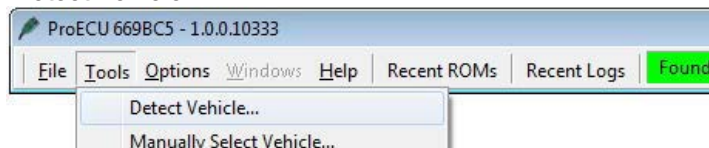

18. Verify Program Engine ECU is highlighted and select OK.

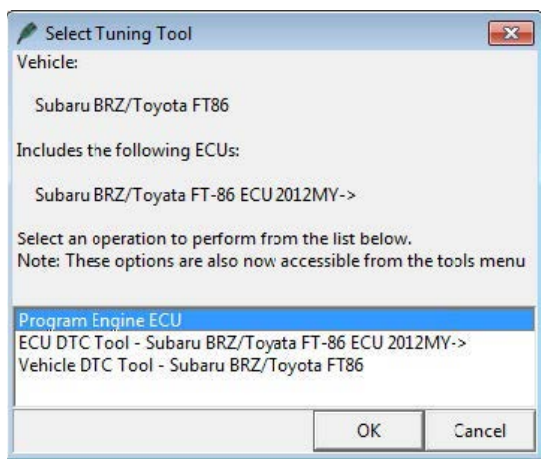

19. The ProECU Programming Tools window will only be displayed if ProECU successfully established a connection to the ECU. Proceed to Step 20 if you have established a successful connection. If not, please proceed with the cautionary notes.

*NOTE: If you get the following message, this is because the ProECU can't establish communication with the ECU. Follow the instructions on the message window to try and establish a connection. If this doesn't resolve the communication issue, close ProECU, unplug the EcuTek vehicle interface, plug it back in, and restart the software.*

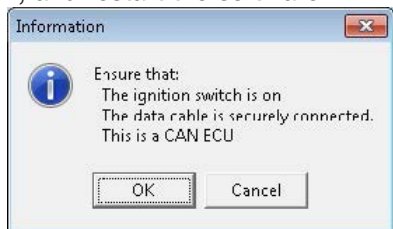

*NOTE: It is possible that you will come across an ECU version that EcuTek will not support. In this rare case, you will not be able to program the ECU until EcuTek has been supplied with certain information*

*about the specific ECU. The 'Dump Details for EcuTek' button saves certain information from this ECU. The information is stored in a file that will be saved into the 'C:\EcuTek\RomDumps' folder. The name of the file will be displayed as it is saved.*

The information in the Dump Details MUST be sent to EcuTek. Together with a clear photograph of the ECU label and details of the following: Vehicle Make, Model, Year, and Manual or Auto gearbox from which the ECU originates. EcuTek will then supply an updated version of ProECU that will be capable of programming the ECU.

Please note that the Turnaround time may take 3 to 4 business days for a supported calibration file to be created. This is why it is highly recommend to verify that the EcuTek is compatible with your ECU version well before starting the supercharger installation. This will alleviate any potential headaches for all parties.

20. Before attempting to reprogram an ECU, first select Query ECU to identify the ECU version fitted to the vehicle. The ECU software version (ROM file name) is shown in the box below the QUERY ECU button, in this example it is 'EU BRZ Manual High (ZA1J700G)'. Other compatible ROMs are shown below the ECU version box.

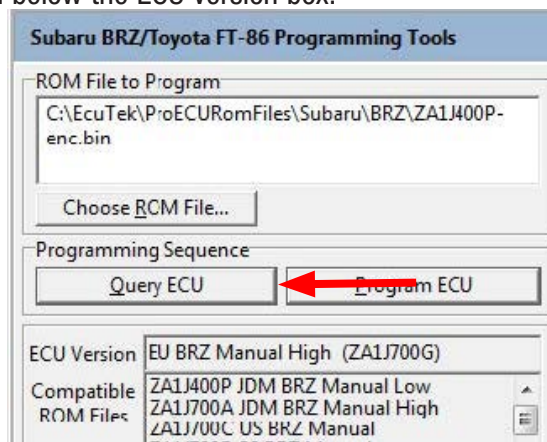



## Edelbrock E-Force Supercharger System 2013-14 BR-Z/FR-S 2.0L

### Installation Instructions

21. Once ECU has been verified to be supported, select the compatible Edelbrock E-Force ROM file. **NOTE:** You will only be able to select a modified ROM file that is based on the original ECU ROM or is a compatible ECU ROM.

**NOTE:** It is only possible to program a RaceROM patched file into the ECU or a completely standard ROM that is provided on EcuTek Update. It is not possible to program a ROM into the ECU that is not shown in the 'Compatible ROM Files' window.

22. With the appropriate ROM file selected, select Program ECU to flash the ECU. This will take a few minutes for the process to complete. After programming the ECU, follow the on-screen instructions to cycle the ignition ON, OFF etc. It is important that this is done in sequence with the appropriate time delays as directed.

**NOTE:** Please refer to the ProECU Programming Overview file included with your software download for more in depth details regarding the EcuTek programming procedure. This will also help if you are experiencing communication issues.

Once the ECU programming is complete, the supercharger installation can begin.

#### SUPERCHARGER INSTALLATION

1. Using a 10mm socket, remove the negative battery terminal. Reinstall the 20A Fuel Pump Fuse.



2. Using a 10mm socket and a panel puller, remove five (5) bolts (red arrow) and two (2) push pin rivets (blue arrow) securing the fascia to the chassis.

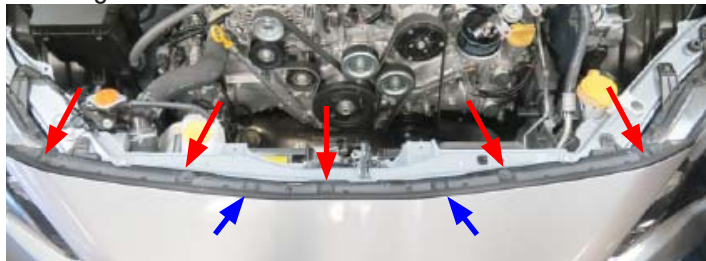

3. Remove the lower splash guard by removing three (3) bolts (green arrow) using a 10mm socket and nine (9) push pin rivets (red arrow) using a panel puller.

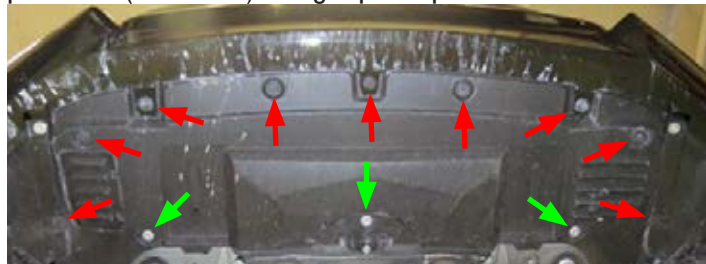

4. Using a 10mm socket, remove three (3) bolts securing the splash guard/fascia support.



5. Use a panel puller to remove two (2) push fit rivets (red arrow) and a 10mm socket to remove two (2) bolts (green arrow) securing the fascia to the outer splash guards.

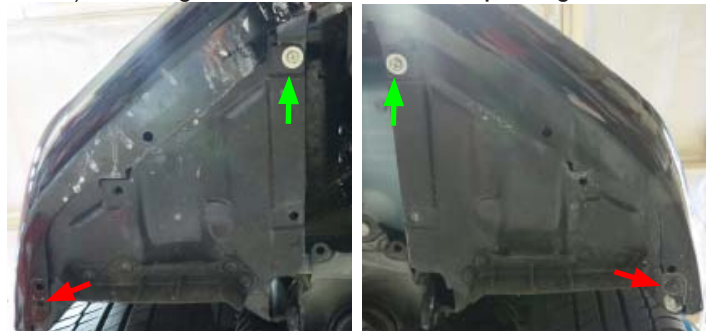

### Installation Instructions

6. Using a Phillips screwdriver and a panel puller, remove six (6) push pin rivets from the wheel well liner (three per side).



7. Carefully remove both side marker lenses by gently pulling out the upper corner of the lenses. Unplug the bulb assemblies and remove. *Tip: Lenses are secured with three (3) metal clips pointed out by the red arrows.*



8. Using a panel puller, remove a push pin rivets securing the front fascia to the fender.



9. Unplug any front fog lights, if applicable, and carefully remove the front fascia.

10. With the fascia removed, use a panel puller to remove two (2) push pin rivets securing the splash guard/fascia support and remove.



11. Connect a rubber hose to the drain barb located on the petcock. Place the other end of the hose into a drain bucket and loosen the petcock to drain the radiator fluid. *TIP: Rubber hose is not require but will limit spillage and cleanup.*



12. Using a hose clamp tool, or equivalent, remove the driver side PCV hose from the air inlet tube.



### Installation Instructions

13. Remove the air inlet tube from the air box, throttle body and noise generator by loosening the worm clamps with a screwdriver.



14. Using a 10mm socket, remove two (2) bolts securing the noise generator assembly to the ECU mounting plate. Disconnect the noise generator hose from the firewall and plug the hole with the 1" sheet metal plug from Bag #4.



15. Remove the MAF harness from the A/C compressor pulley cover. Unplug the MAF sensor and remove it from the air box assembly using a small Phillips screwdriver. Place the MAF sensor in a clean area as it will be reused later.

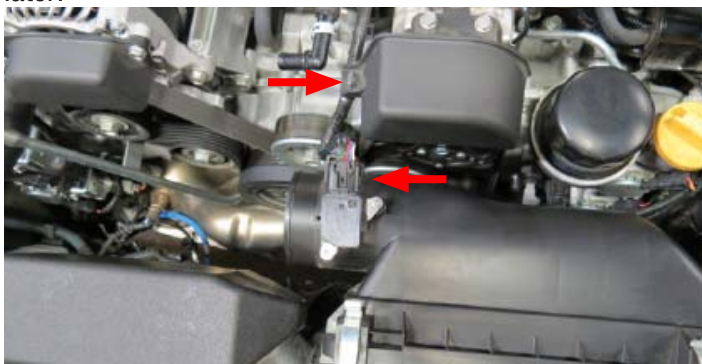

16. Using a 10mm socket, remove three (3) bolts securing the upper air box assembly and remove.



17. Using a 10mm socket, remove two (2) bolts securing the lower air box assembly and remove.

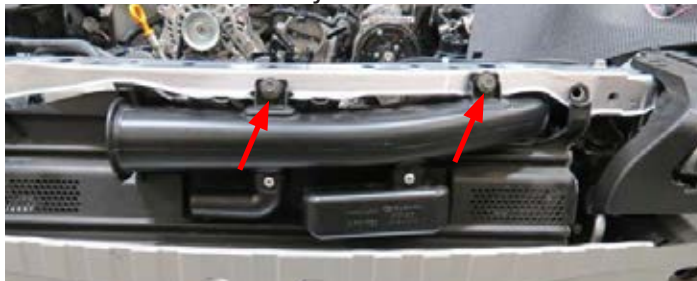

18. Using a panel puller, remove six (6) push pin rivets securing the radiator shroud and remove.



19. Remove the A/C compressor clip (blue arrow) from the compressor pulley cover and unplug the connector. Using a 10mm socket, remove the alternator and compressor pulley covers.

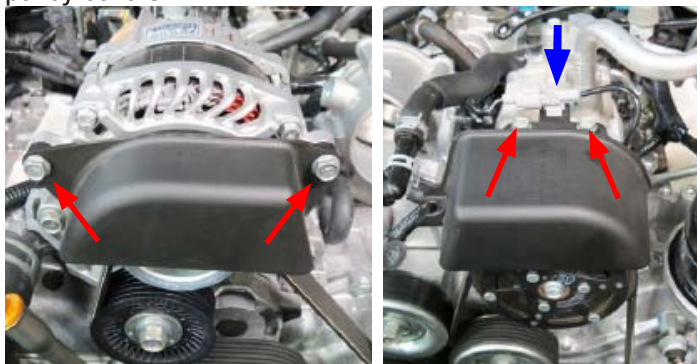

### Installation Instructions

20. Using a 14mm socket, rotate the tensioner clockwise to release the tension from the drive belt and remove the belt.



21. Press in the front of the manifold cover to release the locking tab and remove the cover from the manifold.



22. Unplug the MAP sensor connector located on top of the driver side intake manifold runner.



23. Disconnect the throttle body connector from the throttle body.



24. Remove the PCV and brake booster hoses attached to the top of the intake manifold. *NOTE: Automatic applications will have a PCV hose and a rubber cap.*



25. Unplug the alternator voltage control connector and remove the alternator power cable using a 12mm socket.



26. Remove the engine and alternator harness supports from the ECU mounting plate by pushing the locking tab in and pulling up.



27. Remove all harness connectors from the ECU by depressing the locking tabs on the connectors and then rotating the connector levers outward until they release from the ECU.



### Installation Instructions

28. Using a 12mm socket, remove two (2) bolts securing the sides of ECU mounting plate assembly to the engine. There is an additional bolt securing the bottom of the ECU mounting plate, remove this with a 10mm socket. Carefully remove the ECU mounting plate assembly and set aside.

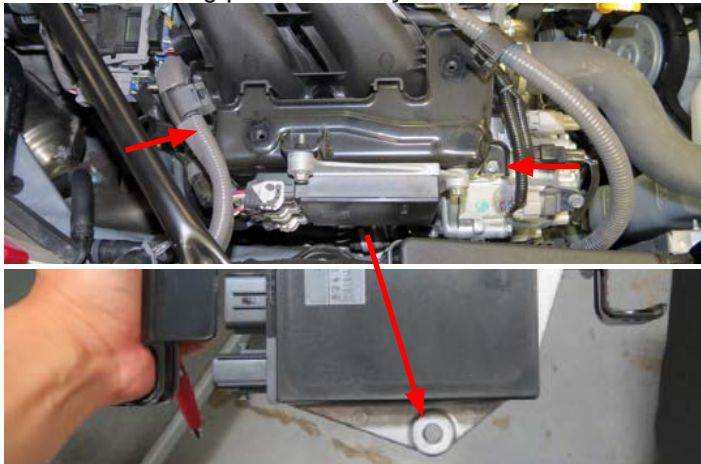

29. Place a rag under the fuel crossover line to absorb any fuel that may leak. Release the blue locking clip located on the fuel crossover line and carefully remove the fuel crossover line from the passenger side fuel rail.

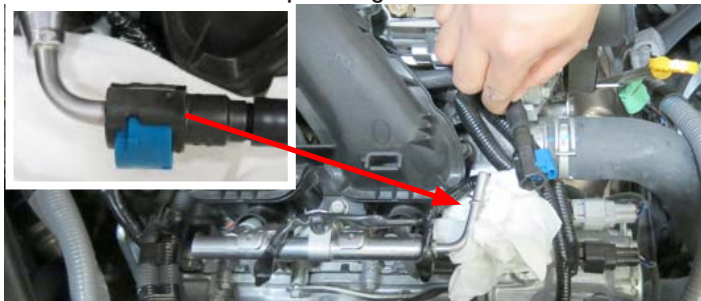

30. Remove the plastic rivet securing the fuel injector harness to the fuel rail using needle nose pliers, then unplug the passenger side fuel injector connectors. Using a 12mm socket, remove two (2) bolts securing the fuel rail to the manifold. Carefully remove the fuel rail assembly and set aside as it will be reused later.

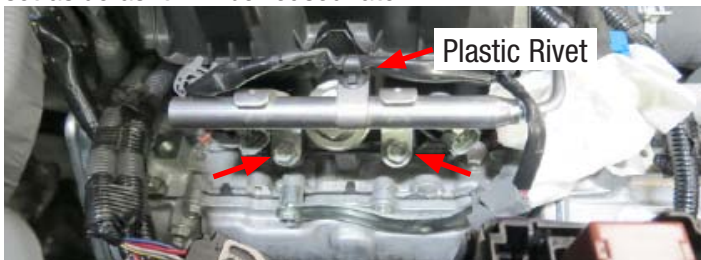

31. Inspect the fuel injectors to verify the O-ring seals are present. If not, the seals may be lodged inside the manifold injector provisions. Carefully use a small flat head screw driver to remove the seals and set them aside as they will be reused later. Replace damaged O-ring seals as needed.

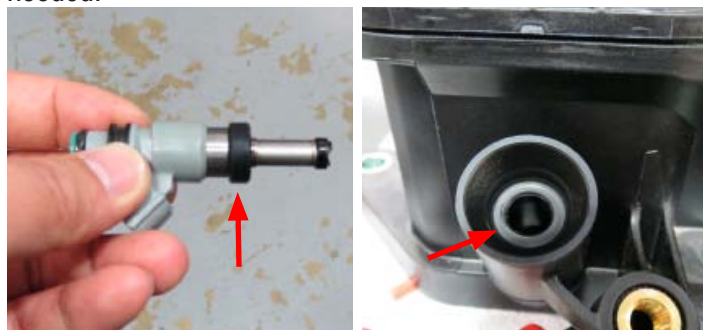

32. Using a 10mm socket, remove the EVAP line support bracket from the driver side manifold.



33. Disconnect the rubber EVAP hose from the EVAP hard line.



### Installation Instructions

*NOTE: Step 34 only applies to Automatic Transmission applications. Disregard otherwise and proceed to the next step.*

34. Using needle nose pliers, remove the plastic rivet securing the transmission harness to the manifold support bracket. Using a 10mm socket, remove the transmission harness mounting bracket.



35. Using a 12mm socket, remove two (2) bolts securing the driver side manifold support bracket to the engine. *NOTE: Removal of the driver side strut brace will simplify this procedure but is not required. Reinstall the strut brace once the driver side support bracket is removed.*



36. Carefully work the manifold support bracket towards the front of the vehicle and remove.



37. Release the blue locking clip from the fuel crossover and disconnect the crossover line from the driver side fuel rail.

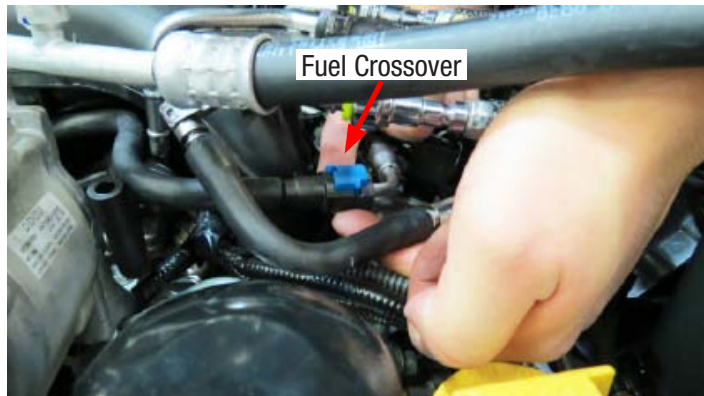

38. Unplug the driver side fuel injector connectors. Using needle nose pliers, remove the plastic rivet securing the injector harness to the fuel rail.



39. Using a 12mm socket, remove two (2) bolts securing the driver side fuel rail to the manifold. Remove fuel rail assembly and move aside.





### Installation Instructions

40. Inspect the fuel injectors to verify the O-ring seals are present. If not, the seals may be lodged inside the injector provisions. Carefully use a small flat head screw driver to remove the seals and set them aside as they will be reused later. Replace damaged O-ring seals as needed.



41. Using a Subaru fuel line removal tool #42099AE000, or equivalent, remove the low pressure fuel feed line from the driver side fuel rail assembly. Remove fuel rail assembly and set aside as it will be reused later.



42. Using the fuel line removal tool, remove the other low pressure fuel feed line from the hard line leading to the mechanical fuel pump.



43. Using pliers, remove the rubber EVAP line from the hard line assembly.



44. Using a 10mm socket, unbolt the throttle body from the intake manifold. Position the throttle body towards the front of the vehicle but do not disconnect the coolant lines at this time.



45. Using needle nose pliers, remove the engine harness from the rear passenger side manifold runner. Using a 12mm socket, remove three (3) bolts securing the passenger side of the manifold to the cylinder heads.

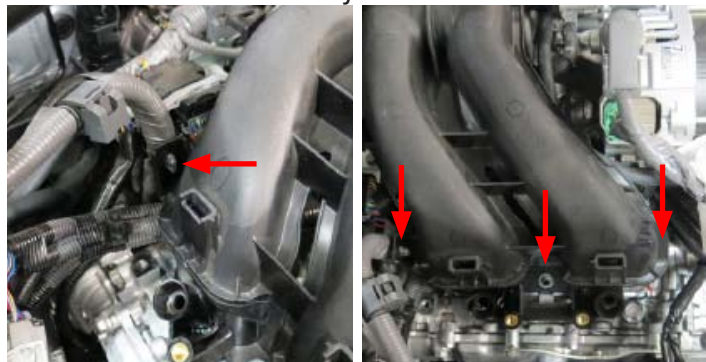

46. Using a 12mm socket, remove three (3) bolts securing the driver side manifold to the cylinder heads.

### Installation Instructions

47. Carefully tilt the manifold forward and unplug the blue EVAP connector from the EVAP extension harness behind the driver side manifold runner.



48. Carefully remove the intake manifold and set aside.

49. Clean the cylinder head flanges with a shop rag and cover the intake ports with protective tape to prevent foreign debris from falling into the ports.



*NOTE: Steps 50-54 only applies to Manual Transmission applications. Disregard otherwise and skip to Step 55.*

50. Manual transmission applications will have to flip and clock the rubber hydraulic line to clear the manifold assembly. To do so, remove the banjo bolt securing the hydraulic clutch line to the slave cylinder using a 14mm socket.



51. Remove the crush washer from the banjo bolt and from the bottom of the banjo end and discard.

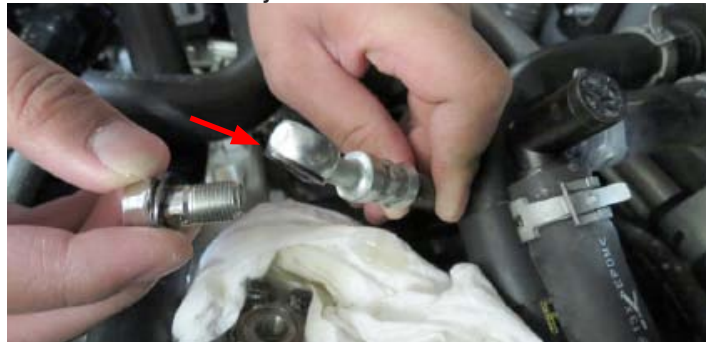

52. Route the clutch line underneath the heater hoses and orientate the clutch line so that it's pointing downwards and clocked towards the driver side of the vehicle. Secure the clutch line using the factory banjo bolt and the supplied 10mm crush washers from Bag #3. *NOTE: Verify that you are using the two smaller crush washer provided. There are also two larger 12mm crush washers supplied in the same hardware bag. Crush washers must be installed on each side of the banjo fitting to prevent leaks.* Torque banjo bolt to 13 ft-lbs (18Nm).



53. Fill the clutch reservoir to the MAX line with FMVSS No. 116 DOT3 brake fluid, or equivalent. *NOTE: During the clutch bleeding procedure, DO NOT let the clutch fluid in the reservoir go below the MIN line.*

### Installation Instructions

54. Connect a rubber hose to the slave cylinder bleeder plug and place the hose into a drain container. Depress the clutch pedal 4-5 times, then loosen the bleeder plug with an 8mm wrench, while the clutch pedal is fully depressed. With the clutch pedal fully depressed, tighten the bleeder plug. Repeat this procedure 3-4 times as needed. After bleeding the clutch, torque the bleeder plug to 5-6 ft-lbs (7.8Nm). Discard the drained clutch fluid and fill clutch reservoir as needed.



55. Using a 17mm wrench, remove the banjo bolt securing the low pressure fuel feed line to the mechanical fuel pump. Remove the fuel feed line as it will not be reused.



56. Assemble the supplied banjo fuel fitting from Bag #3 using the supplied 12mm crush washers and the factory banjo bolt.

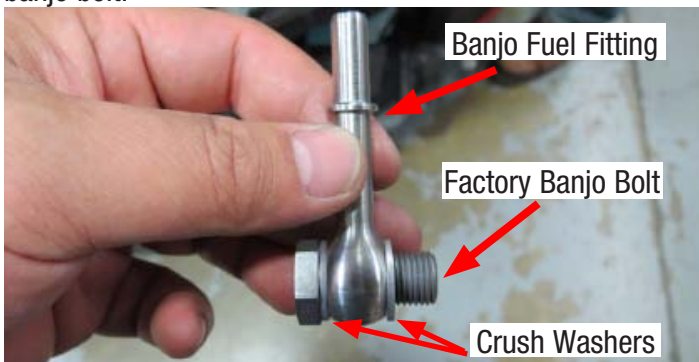

57. Carefully install the banjo fuel fitting assembly onto the mechanical fuel pump. Clock the fitting to the 1 o'clock position and torque the banjo bolt to 23 ft.lbs (31 N.m).



58. Install the low pressure fuel feed line onto the banjo fuel fitting. *TIP: Fuel line will be the one closest to the mechanical fuel pump.*

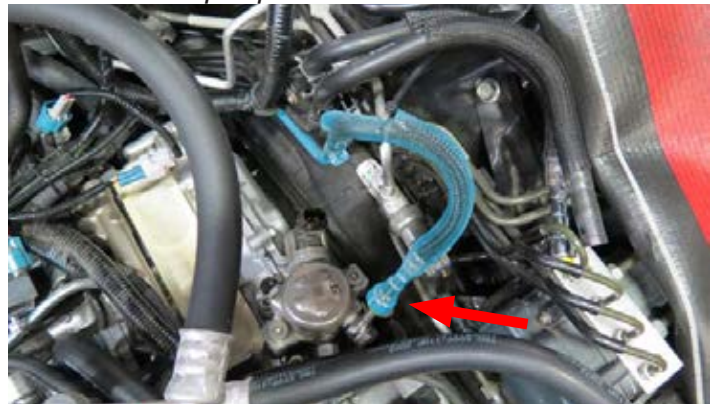

59. Using a hose clamp tool, or equivalent, remove the throttle body coolant outlet hose from the throttle body outlet fitting.

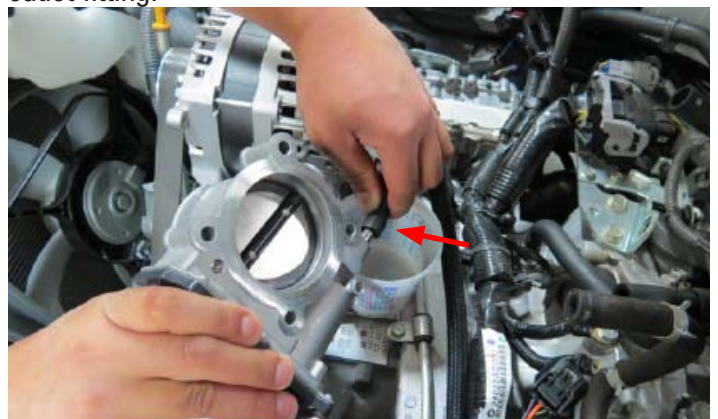

### Installation Instructions

60. Using a hose clamp tool, or equivalent, remove the throttle body coolant inlet hose from the throttle body inlet fitting. Set the throttle body aside as it will be reused later.



61. Remove the throttle body coolant hose from the coolant crossover using a hose clamp tool, or equivalent.



62. Install the straight end of the supplied throttle body inlet hose to the coolant crossover and secure with the factory hose clamp.



63. Remove the passenger side PCV hose.



64. Install the 90° end of the supplied passenger side PCV hose onto the passenger side PCV fitting. Secure hose with a 5/8" hose clamp from Bag #4.



65. Using long needle nose pliers, remove the throttle body outlet coolant line from the driver side cylinder head fitting.



### Installation Instructions

66. Remove the nylon braided sleeve from the factory throttle body outlet hose and install it onto the supplied throttle body outlet hose. Trim braided sleeve as needed.

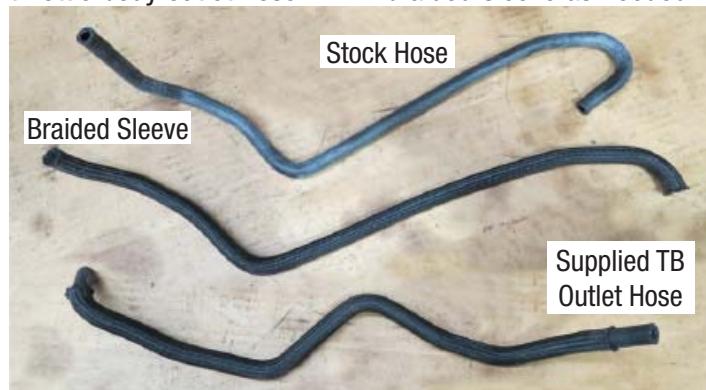

67. Install the straight end of the supplied throttle body outlet hose onto the driver side cylinder head coolant fitting and secure with a factory hose clamp. Route the hose under the engine harnesses and towards the front of the vehicle.



68. Using a hose clamp tool, or equivalent, remove the passenger side heater hose from the heater core fitting located on the firewall.



69. Using a hose cutter, or equivalent, cut approximately 1.75" from the passenger side heater hose.



70. Reinstall the heater hose onto the heater core fitting using the factory hose clamp. Reposition the protective sleeve to where the driver side hose clamp contacts the passenger side hose. Re-secure the hose clip to the heater hoses.

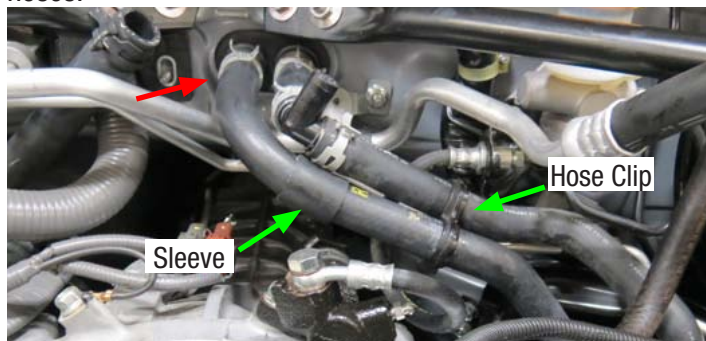

*NOTE: Steps 71-72 only applies to manual transmission applications. Automatic applications skip to Step 75.*

71. Using a hose clamp tool, or equivalent, remove the brake booster hose from the brake booster hard line.





## Edelbrock E-Force Supercharger System 2013-14 BR-Z/FR-S 2.0L

### Installation Instructions

72. Install the supplied brake booster hose, with the end that says brake booster, onto the brake booster hard line. Secure the hose with a 5/8" hose clamp from Bag #4.



*NOTE: Steps 73-74 only applies to automatic transmission applications. Manual applications disregard and proceed to Step 75.*

73. Remove the two transmission connectors from the mounting bracket located adjacent to the heater hoses.



74. Relocate the transmission plugs and harness behind the heater hoses. Secure the harness and plugs to existing engine harnesses and A/C lines with wire ties as designated by the green arrows.

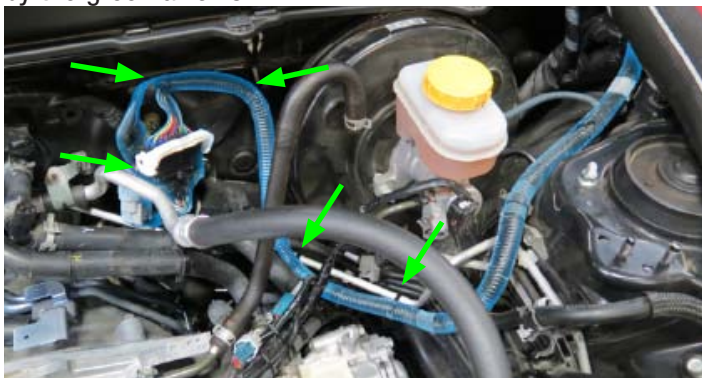

75. Mount the relay and ground strap on the water pump harness to the chassis bolt adjacent to the fuse box.



76. Route the Fuse Holder and Power +12V terminal, on the water pump harness, around the fuse box and towards the battery. Route the EVAP connector over towards the driver side cylinder head.



77. Connect the +12V Constant Power terminal to the positive stud on the battery terminal. Secure the Fuse to existing wire looms with wire ties.





## Edelbrock E-Force Supercharger System 2013-14 BR-Z/FR-S 2.0L

### Installation Instructions

78. Connect the EVAP connector on the water pump harness to the factory EVAP connector located on the engine harness. Secure the water pump harness to existing wire looms every 6-7 inches with wire ties.



81. Secure the EVAP solenoid to the EVAP bracket using the factory nut. Connect the EVAP extension to the EVAP connector located on the water pump harness.



79. Using a 12mm socket, remove the bolt securing the brake booster hard line to the engine. Position the supplied EVAP bracket under the brake booster line and secure the EVAP bracket and brake booster line using the factory bolt.



82. Using pliers, remove the factory EVAP hose from the hard line located in between the low pressure fuel feed lines.



80. Remove the EVAP solenoid from the bottom of the factory intake manifold.



83. Connect the supplied 29" EVAP hose to the factory EVAP hard line. Route the hose towards the A/C compressor and under the driver side PCV hose. Connect the other end of the EVAP hose to the EVAP solenoid fitting farthest from the connector. Secure the EVAP hose to the solenoid using a 5/8" hose clamp from Bag #4.



### Installation Instructions

84. Connect the EVAP hose with the 45° fitting to the EVAP solenoid and route the quick connect end towards the front of the vehicle. This will connect to the supercharger nose later.



85. Rotate the tensioner clockwise using a 14mm socket. Insert a small screw driver into the grooves of the tensioner to hold it in position.



86. Using a 12mm and 14mm socket, remove the bolt securing the alternator to the alternator bracket and the bolt securing the alternator bracket to the engine.

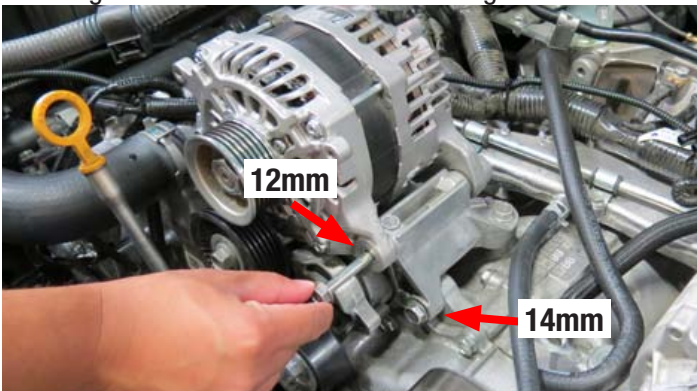

87. Position the supplied FEAD bracket onto the alternator mounting bracket. Using the M10 x 70mm bolt from Bag #1, loosely secure the FEAD bracket to the lower alternator bracket bolt provision.



88. Using the M8 x 170mm bolt and M8 washer from Bag #1, secure the supplied pulley and the FEAD bracket to the top alternator bracket bolt provision. Torque the M8 bolt to 18 ft-lbs and the M10 bolt to 22 ft-lbs.



89. Rotate the tensioner clockwise using a 14mm socket and remove the small screw driver holding the tensioner open.

90. Reinstall the alternator voltage control connector. Place the black-oxide washer, from Bag #3, onto the alternator power cable stud. Clock the alternator power cable to the 8 o'clock position and secure to the alternator using the factory split lock washer and nut.

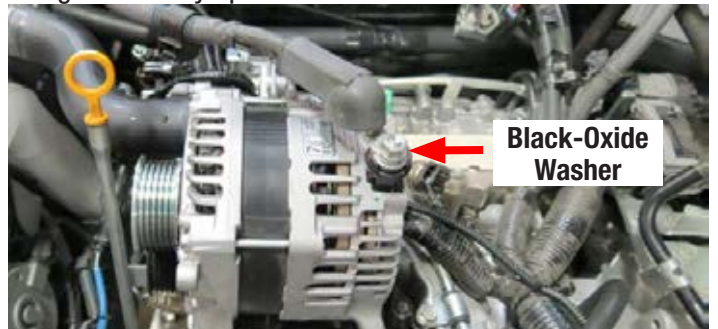



### Installation Instructions

91. Using a 10mm socket, remove four (4) bolts securing the A/C condenser to the radiator assembly.



92. Remove the protective covers on the Low Temp Radiator (LTR) fittings. Carefully position the LTR, with the fittings pointing towards the passenger side of the vehicle, onto the A/C condenser mounting brackets.

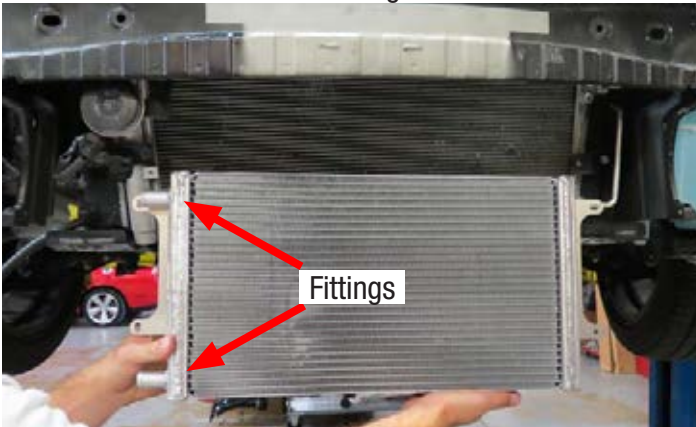

93. Align the A/C condenser and the LTR. Using a 10mm socket, secure the LTR to the A/C condenser using the factory hardware.

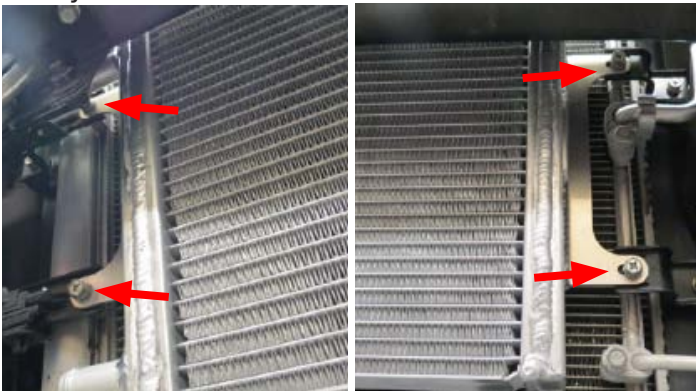

94. Using a 14mm socket, remove the two front lower bolts securing the A/C compressor to the engine.

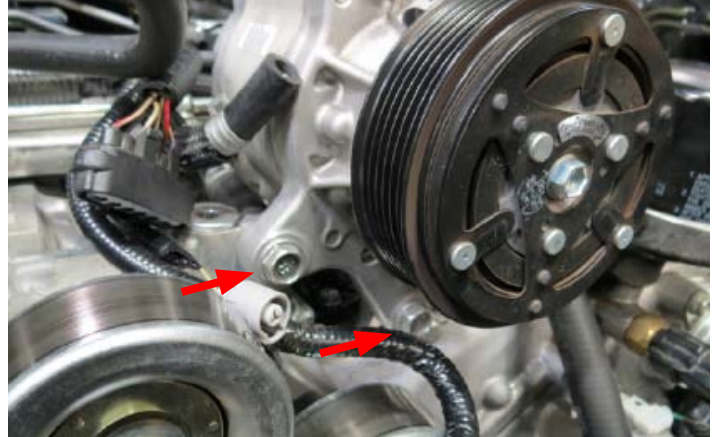

95. Using a 14mm socket, remove the rear A/C compressor bolt and carefully position the compressor forward. *NOTE: DO NOT remove the A/C lines as you will purge all of the pressurized freon.*



96. Using pliers, remove the driver side PCV hose located under the A/C compressor





## Edelbrock E-Force Supercharger System 2013-14 BR-Z/FR-S 2.0L

### Installation Instructions

97. Install the supplied driver side PCV hose to the fitting under the A/C compressor and secure with a factory hose clamp. Route the hose under the A/C lines and towards the oil filter.



98. Remove the factory intake manifold gasket seals from the intake manifold flange. Clean and inspect the gasket for tears and replace damaged gasket seals as needed (#SU00300290). Install the gasket seals onto the supercharger intake flange.



99. Protect both the front and rear engine harness with shop towels because they will rub against the supercharger flange during the installation process. Carefully push the harness branches outward and away from the runner flange.

100. Remove the protective tape from the cylinder heads. With the help from an assistant, carefully lower the supercharger manifold onto the cylinder heads, starting with the driver side runner first.



101. With the supercharger manifold properly positioned onto the cylinder heads, reinstall the A/C compressor and torque bolts to 22 ft lbs. TIP: The rear compressor bolt can be accessed through the opening of the driver side runner using a long extension and a universal socket.



102. Position the supercharger forward to access the rear intercooler fittings. Install the straight end of the Intercooler-to-LTR Hose onto the driver side intercooler fitting and secure the hose with a 3/4" hose clamp from Bag #2. Position the 3/4" hose clamp ears away from the brake lines. Route the hose under the strut brace, in between the cylinder head and fuse box, and down towards the LTR.





## Edelbrock E-Force Supercharger System 2013-14 BR-Z/FR-S 2.0L

### Installation Instructions

103. Secure the LTR-to-Intercooler Hose to the lower LTR fitting with a 3/4" hose clamp from Bag #2.



104. Install the Intercooler to Surge Tank hose onto the passenger side intercooler fitting and secure it with a 3/4" hose clamp from Bag #2. Position the 3/4" hose clamp ears away from the brake lines. Route the hose along side the previously installed intercooler hose.



105. Attach the supplied surge tank to the other end of the Intercooler-to-Surge Tank hose and secure it with a 3/4" hose clamp from Bag #2.



106. Using a 3/4" hose clamp from Bag #2, secure the 90° end of the Surge Tank to W/P hose onto the surge tank. Route the other end of the hose down towards the horn assembly along side the previously routed LTR hose.



107. Using a 10mm socket, remove the bolt securing the front of the fuse box. Insert the surge tank bracket under the fuse box and secure the bracket along with the fuse box with the factory bolt.



108. Using two (2) M6 x 10mm bolts from Bag #2, secure the surge tank to the surge tank bracket.





## Edelbrock E-Force Supercharger System 2013-14 BR-Z/FR-S 2.0L

### Installation Instructions

109. Install the supplied 3/8" rubber vacuum hose onto the purge fitting of the surge tank. Route the hose down towards the radiator petcock and secure to existing hoses with wire ties.



110. With the intercooler hoses properly secured, reposition the supercharger rearwards. Noting the orientation of the factory fuel crossover line, carefully snake the line under the supercharger nose, behind the alternator and out in front of the passenger side runner.



111. Snake the other end of the fuel crossover behind the A/C compressor and out in front of the driver side runner.



112. Realign the supercharger to the cylinder heads. Using two (2) M8 x 30mm bolts and one (1) M8 x 50 bolt, loosely secure the driver side runner to the cylinder head.

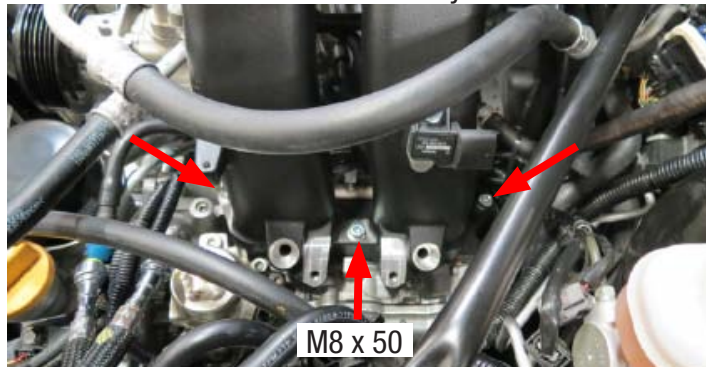

113. Using two (2) M8 x 30mm bolts and one (1) M8 x 50 bolt, loosely secure the passenger side runner to the cylinder head. Torque all six (6) bolts to 10 ft-lbs, starting with the center bolts and working outwards,

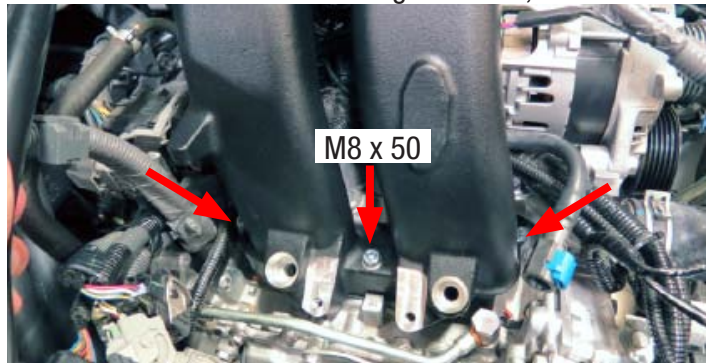

114. Remove the injector O-ring seals from the injectors. Apply O-ring lube to the seals and place the flat side into the injector provision on the supercharger manifold.



### Installation Instructions

115. With the fuel injectors securely positioned on the passenger side fuel rail, carefully install the fuel rail assembly with the injector connectors oriented outwards. Secure the fuel rails with the factory bolts and torque to 10 ft-lbs. Reconnect the fuel injector connectors.



116. Connect the passenger side fuel crossover line to the fuel rail and engage the blue locking clip.



117. With the fuel injectors securely positioned on the driver side fuel rail, carefully install the fuel rail assembly with the injector connectors oriented outwards. Secure the fuel rails with the factory bolts and torque to 10 ft-lbs. Reconnect the fuel injector connectors.



118. Connect the fuel crossover line to the driver side fuel rail and engage the blue locking clip.



119. Connect the low pressure fuel feed line to the driver side fuel rail. Verify the lock is engaged by gently tugging on the fuel line.



120. Reinstall the ECU mounting plate assembly using the factory hardware. Reconnect all ECU connections and reattach the engine harness and alternator harnesses to ECU plate.

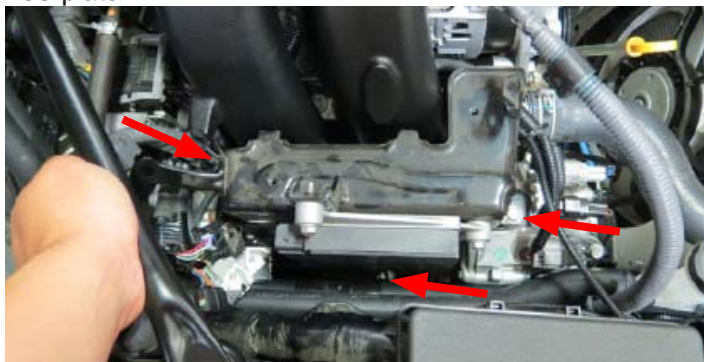

### Installation Instructions

121. Secure the nose support bracket to the FEAD bracket using two (2) M6 x 12mm button head bolts from Bag #1. *NOTE: Shift bracket upwards before tightening the bolts.*

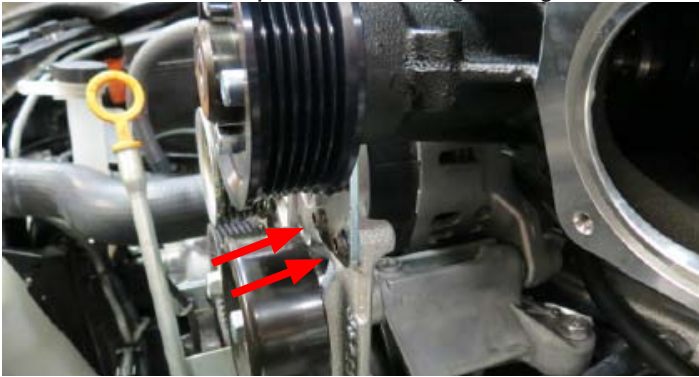

122. Connect the 45° end of the previously installed EVAP hose to the top nose fitting. Connect the RH/Passenger PCV to the bottom nose fitting. Manual applications will connect the Brake Booster hose to the center nose fitting. Automatic applications will remove the fitting plug from the stock intake manifold and install it to the center nose fitting.

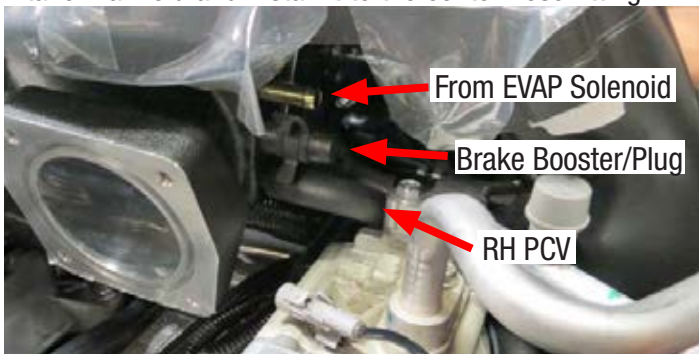

123. Using two (2) M6 x 12mm Button Head bolts from Bag #4, secure the LH PCV Support Bracket to the A/C compressor. Attach the A/C compressor connector to the bracket.



124. Remove the throttle body O-ring seal from the factory manifold. Using side cutters, or equivalent, remove the tip from the O-ring seal.



125. Install the O-ring seal onto the supercharger throttle body flange. Connect the throttle body coolant inlet hose to the inlet fitting and secure with the factory hose clamp.



126. Using the factory throttle body bolts, secure the throttle body to the supercharger with the connector oriented upwards.

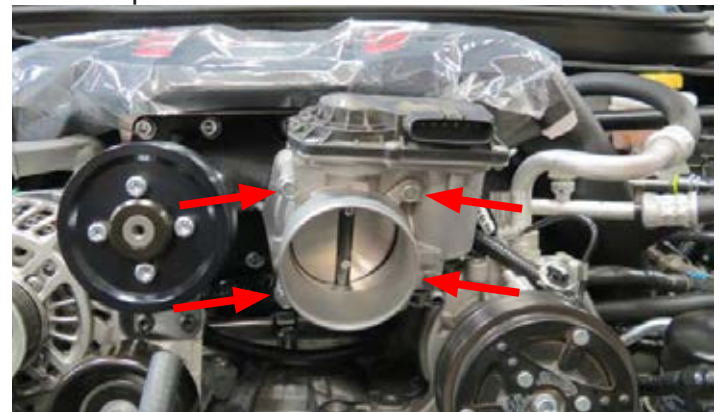



## Edelbrock E-Force Supercharger System 2013-14 BR-Z/FR-S 2.0L

### Installation Instructions

127. Connect the throttle body extension harness to the throttle body connector and then to the throttle body.



128. Using a factory hose clamp, secure the throttle body coolant outlet hose to the throttle body outlet fitting.



129. Using a 14mm socket, rotate the belt tensioner clockwise and install the supplied drive belt using the routing diagram below.

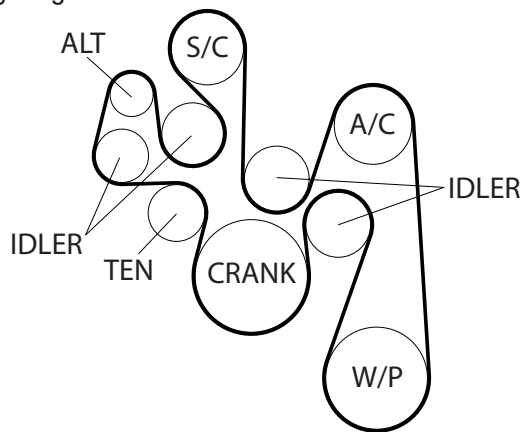

*NOTE: Steps 130-132 are for vehicles equipped with external Daytime Running Light Resistors. The resistor will have to be relocated using the supplied hardware. Disregard otherwise.*

130. Using a 10mm socket and needle nose pliers, remove the DRL resistor and the connector from their mounting locations.



131. Using a drill and a 10mm drill bit, drill out the hole located on the crash beam support. Using a rivet nut tool, or equivalent, install the rivet nut from Bag #2 to the crash beam support.



132. Secure the resistor to the rivet nut with the M5 x 20mm bolt from Bag #2. Secure the harness to existing vehicle harnesses as needed.





## Edelbrock E-Force Supercharger System 2013-14 BR-Z/FR-S 2.0L

### Installation Instructions

133. Using two (2) M6 x 10mm bolts from Bag #2, install the water pump bracket to the location adjacent to the left horn assembly. *TIP: The upper bolt goes through the frame behind the bracket. The lower bolt goes through the bracket into the welded nut on the frame.*



134. Using a 3/4" hose clamp from Bag #2, secure the LTR to W/P Hose to the top LTR fitting.



135. Route the W/P end of the hose down and over towards the water pump bracket.



136. Install the supplied water pump onto the water pump isolator and install the assembly onto the water pump bracket. Clock the water pump so that the outlet fitting is perpendicular to the body and pointing towards the driver side of the vehicle.

137. Using 3/4" hose clamps from Bag #2, secure the Surge Tank to W/P hose to the water pump's inlet fitting (top). Secure the W/P to LTR hose to the water pump's outlet fitting.



138. Route the water pump connector, from the previously installed water pump harness, down towards the water pump and connect it to the water pump. Secure the harness to existing wire looms and/or hoses.



139. Using a 12mm socket, loosen four (4) bolt securing the top radiator support.





### Installation Instructions

140. Using a 12mm socket, remove two (2) bolt securing the lower center radiator support.



141. Install the isolator onto the lower air box support bracket. Using a 10mm socket, remove the bottom bolt securing the hood latch assembly and install the supplied lower air box support bracket using the factory bolt.

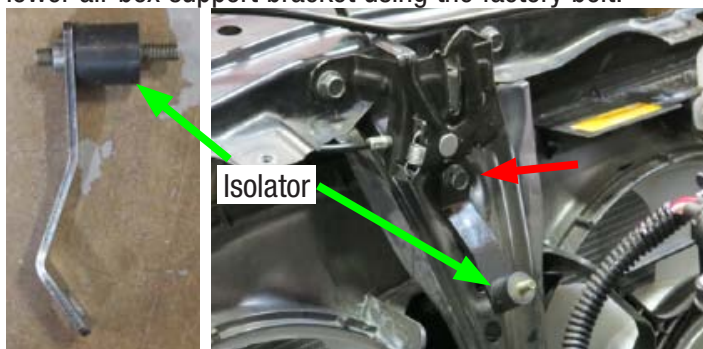

142. Install the 5/16" grommet and grommet sleeve from Bag #3 onto the left air box bracket.



143. Loosely install the left air box bracket to the air box using two (2) M6 x 10mm Button Head bolts from Bag #4.



144. Install the supplied 5/16" grommet and grommet spacer onto the air duct of the front air box shroud.



145. Lift up the upper radiator support and insert the front air box shroud until the lip of the air duct protrudes past the insulator foam above the A/C condenser.

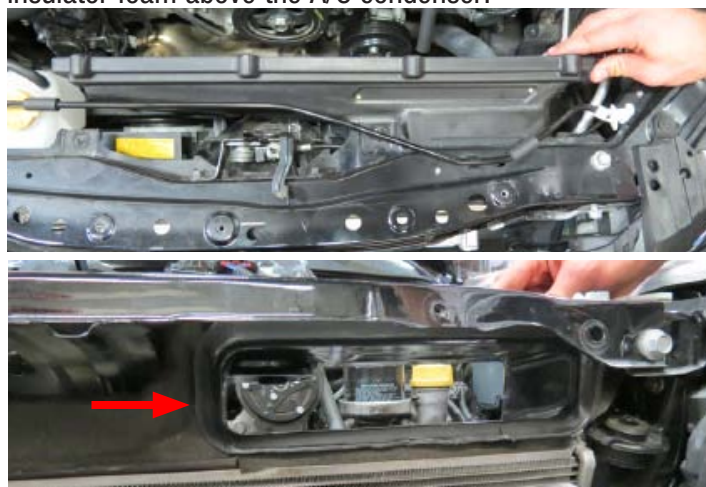

146. Use the M6 x 16mm Hex Flange bolt from Bag #4 to secure the front air box shroud to the upper radiator support. This is done from the inside of the air box by threading the bolt through the welded nut on the radiator support.



### Installation Instructions

147. Use the M6 x 16mm Hex Flange bolt from Bag #4 to secure the left air box support bracket to the upper radiator support. This is done by threading the bolt through the welded nut on the radiator support. Fasten the two (2) M6 x 10mm Button Head bolts from Step #143.



148. Use a M6 locknut and a M6 washer from Bag #4 to secure the front air box shroud to the isolator.



149. Re-secure the top radiator support using the factory hardware.

150. Using the supplied grease from the air filter kit, apply a thin 1/8" bead of grease inside the channel of the air filter. This will help prevent unwanted debris from bypassing the filter. *TIP: Grease should protrude past the channel.*



151. Install the air filter into the front air box shroud.



152. Install the 1/2" grommet and 1/2" barb fitting from Bag #4 to the rear air box shroud.



153. Install the supplied MAF O-ring from Bag #4 onto the MAF sensor. Install the factory MAF sensor onto the supplied MAF housing with two (2) M4 x 10mm Button Head bolts from Bag #4.



154. Using the worm clamps, secure the tapered coupler and the straight coupler to the MAF housing.



### Installation Instructions

155. Place the rear air box shroud over the front air box shroud with the barb fitting on the driver side of the vehicle. Rotate the rear air box shroud upwards and loosely secure the MAF housing assembly onto the throttle body and air box using the supplied worm clamps.



156. Clock the worm clamps to position the screws away from the A/C compressor belt/pulley. Double check that there is at least 6mm clearance between the coolant line on the throttle body and the belt on the AC compressor pulley.

**GOOD**

**BAD**



157. Secure the rear air box shroud to the front shroud using eight (8) M6 x 12mm Button Head bolts and eight (8) washers from Bag #4.



158. Connect the previously installed driver side PCV hose to the 1/2" barb fitting on the rear air box shroud.

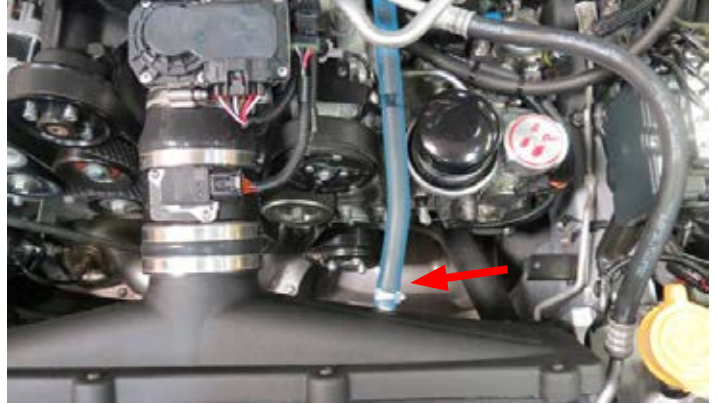

159. Using the 3/4" Hose Clamp and M5 x 8mm Button Head Flange bolt from Bag #4, secure the driver side PCV hose to the PCV support bracket.



160. Connect the male MAF sensor connector, on the supplied TMAP harness, to the factory MAF sensor connector. Connect the female MAF sensor connector to the factory MAF sensor.

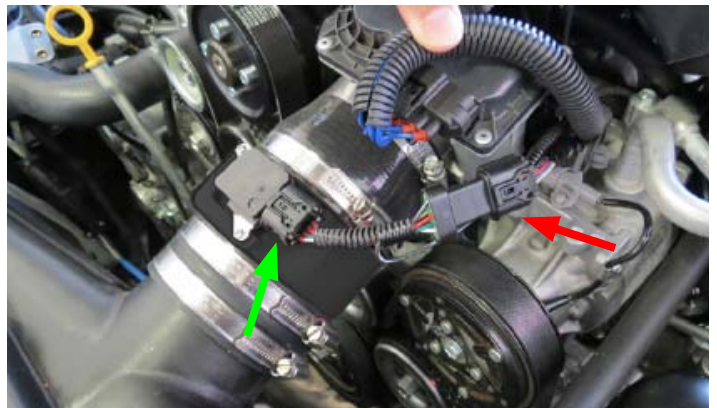



## Edelbrock E-Force Supercharger System 2013-14 BR-Z/FR-S 2.0L

### Installation Instructions

161. Route the TMAP harness under the driver side runner and connect the MAP connector to the factory MAP harness. Connect the TMAP connector to the TMAP sensor located on the driver side runner. Secure the TMAP harness to existing wire looms with wire ties.



162. Using the push mount zip tie from Bag #2, secure the TMAP harness and the throttle body extension harness to the PCV support bracket.



163. Fasten the radiator petcock if not already done so.

164. Reinstall the front fascia and the splash guards using the factory hardware.

165. Using a panel puller, remove nine (9) tree clips securing the hoodliner to the hood. Liner must be removed as it comes in contact with the supercharger manifold.

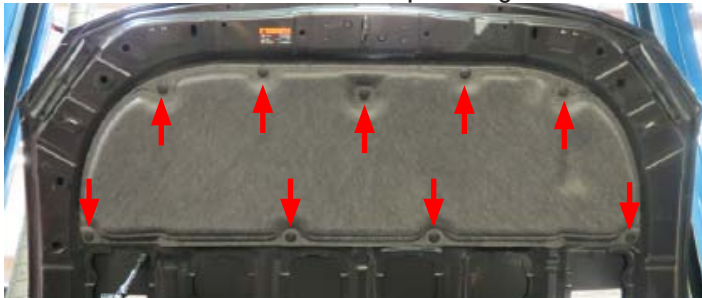

166. Reconnect the Negative battery terminal.

167. Refill the radiator with a mixture of 50/50 coolant to water.

168. Fill the supercharger cooling system with a mixture of 50/50 coolant to water. *NOTE: Please see "How to Prime the Edelbrock E-Force Intercooler Systems" at the end of these instructions for detailed instructions.*

169. This concludes the supercharger installation procedure. If you have not flashed the PCM do so by following the EcuTek ECU Reflashing procedure at the beginning of these instructions. *DO NOT proceed if the PCM has not been flashed.*

170. Turn the ignition on but do NOT start the vehicle (Push the start button twice without your foot on the brake pedal).

171. Check for any fuel leaks around the rails, injectors, and fuel fittings. It is recommended to physically check these areas as a small leak may not be visible. If leaks are present, shut the ignition off immediately and repair leaks before continuing.

172. With the ignition on, verify that the electric water pump is cycling and that water is flowing through the surge tank. *NOTE: Please see "How to Prime the Edelbrock E-Force Intercooler Systems" at the end of these instructions for detailed instructions..*

173. Start the engine and let it come up to operating temperature. Check for any coolant leaks around the throttle body and LTR hoses. Shut the engine off and recheck all fluid levels when safe to do so. Top off fluids as necessary.



## How to Prime the Edelbrock E-Force Intercooler Systems.



***The electric water pump used on this Edelbrock E-Force Supercharger System has a built-in micro-processor that will vary pump cycle speed when air bubbles are present in the system. If a significant amount of air is trapped in the system, the pump may cycle at a slower speed and pulsations are likely to occur resulting in poor cooling performance.***

For the best result, it is highly recommended to use a Radiator Cooling System Vacuum Purge and Refill Kit to properly evacuate the air from the intercooler system before filling with a 50/50 mixture of coolant and distilled water. If one is not available, the following procedure will be adequate.

1. Using the Lisle 24680 Spill-Free Funnel, or equivalent, secure the appropriate filler neck adapter to the surge tank.
2. Attach the funnel and fill with a 50/50 mixture of coolant and distilled water until the funnel is half full.
3. Turn the ignition to the ON position and listen for the pump's electric motor to cycle. Air bubbles will begin to purge from the system as the coolant level drops. Add coolant to the funnel as necessary. *NOTE: Do NOT let the coolant level in the funnel run empty as this may introduce air into the system.*
4. To build more pressure in the intercooler system, try squeezing the intercooler hoses while the pump is cycling. Building pressure in the system will help purge the trapped air from the intercooler system.
5. Cycle the ignition OFF and wait a few seconds for the pump to come to a stop.
6. Cycle the ignition ON again and repeat until the sound of the electric pump is continuous without any pulsation. *NOTE: During water pump start-up, it is normal for a slight pulsation to occur. Once the pump has reached its maximum cycle speed, no pulsations should be present.*
7. Periodically inspect the water pump flow after a few drive cycles and re-fill the intercooler system as necessary.
8. Several drive cycles may be required to completely purge the air from the intercooler system. During a drive cycle, the intercooler system will build up pressure as the supercharger temperature increases. Any residual air trapped in the system will gradually bleed out of the surge tank as the system reaches a pressure above 5psi.

***WARNING: Always avoid removing the surge tank cap when the engine is hot. The hot coolant is under pressure and may spray out causing burns.***