



**Super Victor LS7 Carbureted and EFI Intake Manifold
for GM Gen IV w/ LS7 Cylinder Heads
Catalog #2887, 2890, 28875 & 28905
INSTALLATION INSTRUCTIONS**

PLEASE study these instructions carefully before beginning this installation. Most installations can be accomplished with common tools and procedures. However, you should be familiar with and comfortable working on your vehicle. If you do not feel comfortable performing this installation, it is recommended to have the installation completed by a qualified mechanic.

**IMPORTANT NOTE: Proper installation is the responsibility of the installer.
Improper installation may result in poor performance and engine or vehicle damage.**

Kit Content: #2887 and #2890

- 1 - Carbureted Super Victor Manifold

Kit Content: #28875 and #28905

- 1 - EFI Super Victor Manifold

CAUTION: Make sure the vehicle's battery has been disconnected and that the vehicle is supported on a level surface to prevent any possibility of the vehicle moving during the installation procedure.

MANIFOLD: These single plane, Super Victor LS7 intake manifolds, are intended for racing applications operating between 3,500-8,000 rpm. A fuel rail kit, #3649, designed to work with the EFI manifolds is available separately.

EGR SYSTEM: These manifolds have no provision for EGR (exhaust gas recirculation) equipment. EGR systems are used on most 1972 and later model vehicles. ***This part is not intended for use in any emissions controlled application.***

ACCESSORIES & INSTALLATION ITEMS: Major recommendations are listed below. However, because this manifold system is intended for engine swaps into a variety of vehicles, some customizing may be required.

Super Victor EFI Intake Manifolds (#28875 and #28905)		
ITEM	NOTES	PART NUMBER AND DESCRIPTION
Throttle Body	Standard 4150 or 4500 series throttle bodies with bores diameters up to 2.25"	P/N: 3878 - 4-BBL, 4150 Flange w/ GM Stepper IAC (1.75" Bores) P/N: 3888 - 4-BBL, 4500 Flange, w/ GM Stepper IAC (2.25" Bores)
Fuel Rail Kit	Has vertically machined injector bores.	P/N: 3649 - Super Victor LS7 EFI Fuel Rail Kit, -8 AN Ends (includes mounting hardware)
Super Victor Carbureted Intake Manifolds (#2875 and #2890)		
ITEM	NOTES	PART NUMBER AND DESCRIPTION
Carburetor	Use appropriate 4150 or 4500 Series racing carburetor	Various
Required Items for both Carbureted and EFI Intake Manifolds		
ITEM	NOTES	PART NUMBER AND DESCRIPTION
Manifold Gasket	Due to the larger manifold port exits, the O-Ring gaskets will require some stretching.	P/N: GM #89017852
Throttle Bracket	Requires a Carb Mounted Throttle Bracket	Available at your local performance shop and online retailer.
Bolt Kit	M6 x 1.0 x 45mm Hex flange Heads	P/N: Edelbrock #8515 - GM LS1-LS7 Intake Manifold Bolt Kit

INSTALLATION PROCEDURE:

1. Use original equipment, GM #89017852, intake manifold O-Ring gaskets. As mentioned above, due to the larger port exits on these manifolds, the GM O-Ring gaskets will require a little stretching to fit into the O-Ring grooves. This will have no effect on how the O-Rings seal. Gasket sealer is not required when using OEM type gaskets. Using appropriate mounting hardware (not included) to mount the manifold to the engine. Following the torque sequence in **Figure 1**, torque all manifold bolts to 96 in/lbs (8 ft/lbs).
2. These manifolds require the use of a carb mounted throttle bracket. Carb mounted throttle brackets are available at your local performance shop and online retailer. Select the appropriate cable brackets for your application (large or small opening brackets) and attach them to the throttle bracket with the appropriate hardware.

INJECTOR SELECTION AND INSTALLATION (#28875 and #28905): It is important to select the appropriate electronic injectors for optimum performance. The injectors must not only match the fuel demands of an engine, but they must also match the electronic capability of the engine control unit (ECU). When installing the injectors onto the manifold, make sure that the O-rings of the injectors create a complete seal to prevent any air or fuel leaks. The same precaution should be applied when assembling the injectors to the fuel rails. Use assembly lube on all O-rings when installing injectors.

FINAL CHECKS: After assembling the injectors, fuel rails, support brackets, throttle body, spacer (if needed), gaskets, and air cleaner, check the following:

- Have an assistant depress and release the gas pedal. Check for full open throttle at the throttle body. Check for any possible interference of the throttle with other components. Make sure the throttle can return without binding.
- EFI manifolds need to check the fit of each injector. They should be able to rotate freely. The O-rings should be fully inside their respective bores.
- Activate the fuel pump and fully check the system for any leaks. Repair all leaks prior to starting the engine.

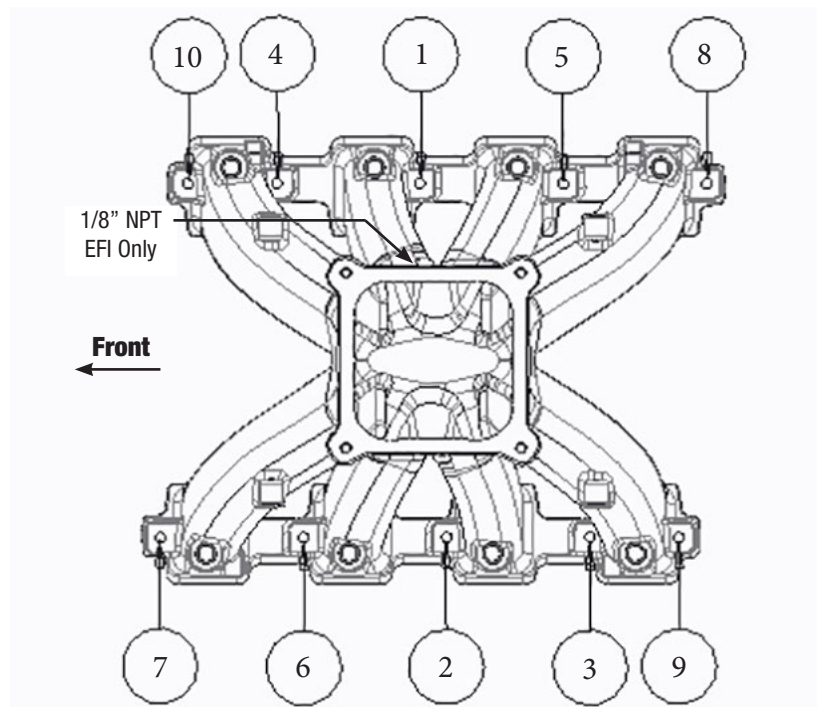

Figure 1 - Intake Manifold Tightening Sequence
Torque All Bolts to 96 in/lbs (8 ft-lbs)

