

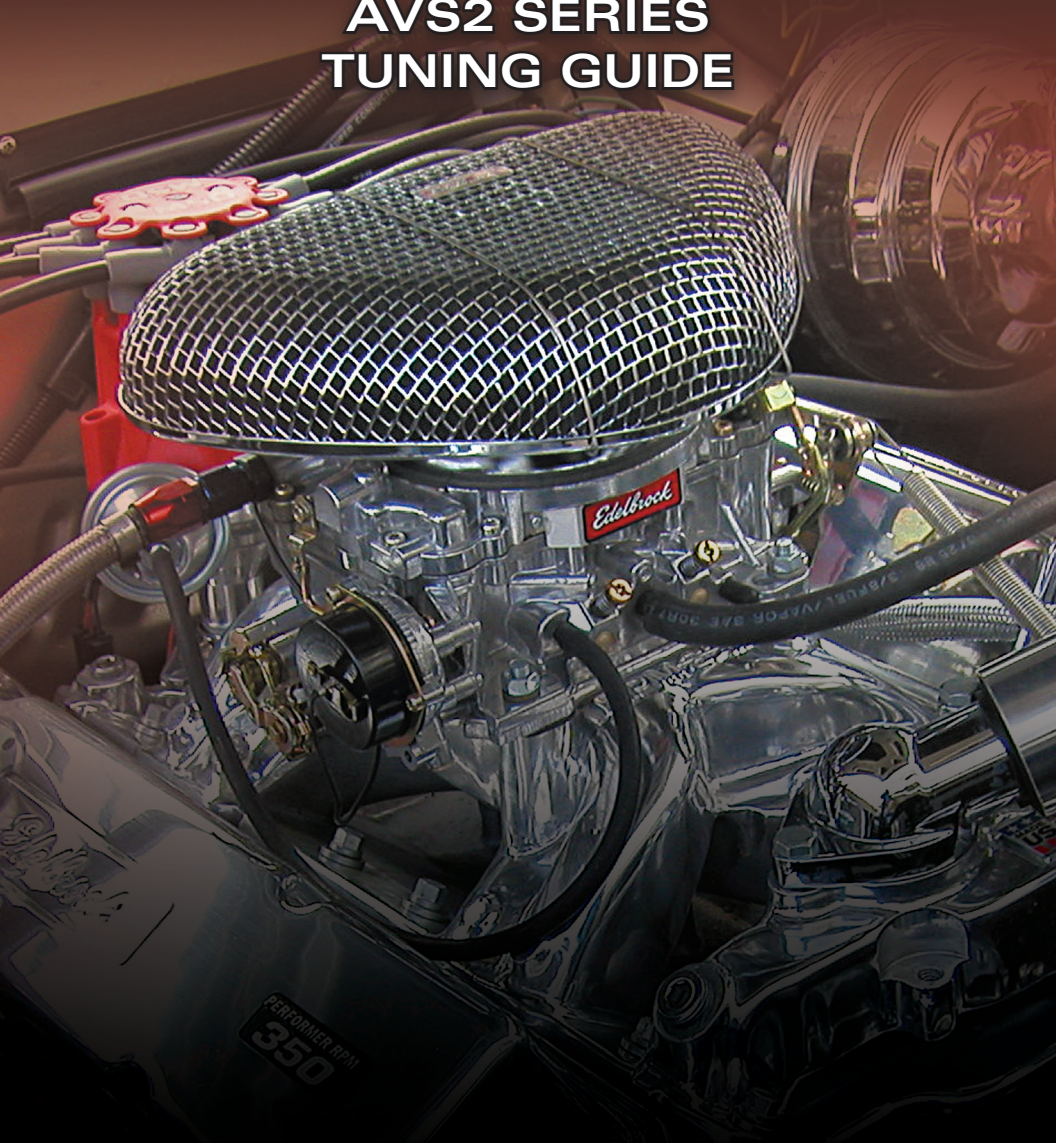

Edelbrock[®]

CARBURETORS

**PERFORMER SERIES
THUNDER SERIES AVS
AVS2 SERIES
TUNING GUIDE**



INTRODUCTION

Your Edelbrock Performer Series, Thunder Series AVS and AVS2 carburetor were calibrated using Edelbrock Performer, Performer RPM, and Torker II Power Packages. The carburetor metering was developed on Edelbrock engine dynamometers, chassis rolls, and a variety of development vehicles. Although in most applications you will not need to recalibrate your carburetor, you may wish to change the factory calibration to best meet any unique needs of your engine.

The following guide consists of 2 sections; Tuning Procedures and Tuning Accessories. The purpose of this guide is to give you the necessary information to prepare and develop your own individualized calibration for your application. The Tuning Procedure section will take you through step-by-step procedures that will enable you to achieve a desirable calibration. For added ease of tuning, a Calibration Reference Chart for your model of carburetor has been included. For the purposes of this guide, when Edelbrock mentioned is referenced, we are referring to our four-barrel Performer Series, Thunder Series AVS and AVS2 carburetor lines.

TABLE OF CONTENTS

REVISING THE CALIBRATION	3
Parts and Equipment	3
Changing Components	4
IDLE MIXTURE	4
Winter Fuel Idle Sets	4
Long Duration Camshaft	5-6
CALIBRATING THE WIDE-OPEN THROTTLE (WOT).....	5-6
CALIBRATING THE PART THROTTLE	6
Cruise Mode.....	6
Power Mode	6
CALIBRATING THE MODE STAGING.....	7
CALIBRATING THE PUMP	7
FLOAT ADJUSTMENT	7
CHOKE ADJUSTMENT	7-8
CARBURETOR SPECIFICATIONS.....	9-10
TROUBLESHOOTING CHART	11-12
CALIBRATION REFERENCE CHARTS	13-32
TUNING ACCESSORIES	33-34
INSTALLATION COMPONENTS	35-38
INLET KITS	39
FUEL FILTER AND HOSE KITS	40
FUEL HOSE KITS.....	41
FUEL DISTRIBUTION BLOCKS	42

TUNING PROCEDURE

REVISING THE CALIBRATION

Before proceeding please ensure you have installed your Edelbrock Performer Series, Thunder Series AVS or AVS2 carburetor according to the Installation Instructions supplied with the carburetor. Edelbrock Carburetors are designed to allow quick and easy changes to the metering. Virtually any change imaginable can be performed without removing the carburetor from the manifold, and the most common changes may be performed in less than five minutes without removal of the airhorn (bowl cover).

To help you calibrate your carburetor, a CALIBRATION REFERENCE CHART has been designed for each model of the Edelbrock Performer Series, Thunder Series AVS, AVS2 carburetors. These charts (pages 13-38) each consist of two sections: A Calibration Table and a Rod/Jet Reference Chart.

After reading the Calibration procedures, the next step in calibrating your carburetor is to look at the Calibration Table for your model carburetor. Determine if you would like to go richer or leaner in the Cruise Mode and do the same for the Power Mode. Select the number that is closest to intersection of your Cruise and Power Mode selections. This is your calibration reference number. Now refer to the Rod/Jet Reference Chart that appears on the opposing page. Locate your calibration reference number to determine the rod/jet combination for your application.

For example, you have a 1405 Edelbrock Performer Series carburetor. You have determined (by reading the rest of the manual) you would like to go 1 stage lean in the Cruise Mode and 2 stages lean in the Power Mode. The intersection of these two lines lies on the number 21. This is your calibration reference number. Now look below the Calibration Table to the Rod/Jet Reference Chart. Find the number 21 under the REF# column. The jets you should use are .098 and the rods are .070 x .052.

Located at the very bottom of each Calibration Reference Chart is a guide for changing your Secondary Metering. This will be useful when calibrating the wide-open-throttle (WOT).

Before you attempt to establish a new calibration, be sure that the engine is in a sound state of tune. All ignition items must be in proper working order, including reasonably fresh plugs of the correct heat range. Timing should be properly set and the air filter element and fuel filter should be clean.

Proper fuel pressure should be verified and cracked or brittle vacuum lines should be eliminated. Many so-called "carburetor calibration" problems have been traced to another part of the engine system that was not functioning properly.

CAUTION: Be alert to carburetor flooding when fuel is first applied. Flooding can be caused by dirt, small particles of hose cuttings, floats and inlet needles which have settled during shipping, or by other conditions as discussed below. Each Edelbrock carburetor is flow tested in the factory for both air and liquid flow so flooding is rare. However, for safety sake please observe this caution. When the fuel pump is turned on or when the engine is first started, watch closely for signs of flooding. If flooding is apparent, tap the body of the carburetor lightly with a rawhide mallet or the wooden handle of a small hammer. If flooding continues, pinch the fuel line hose to shut off flow, run the engine to clear the carburetor, and let the fuel line flow again. If flooding continues, pinch the fuel line hose to shut off flow, run the engine to clear the carburetor, and let the fuel line flow again. If flooding still continues, stop the engine. Clean up any raw gasoline and refer to the "Trouble Shooting" section on pages 13-38.

PARTS AND EQUIPMENT

Aside from ordinary hand tools, the following items are recommended.

- Edelbrock Performer Series, Thunder Series AVS, and AVS2 Carburetor Calibration Kit - Contains selections of Main Jets, Metering Rods, and Springs.
- Tachometer - If the vehicle is not equipped with a tach, the dwell meter style tach will be adequate. If neither is available, you will be able to use the speedometer in place of the tach for some of the procedures, but it will not be as convenient.
- Vacuum Gauge - Should be hooked up to read engine's intake manifold vacuum. Without a vacuum gauge, some of the calibration procedures will be more difficult.

TUNING PROCEDURE

CHANGING COMPONENTS

Metering Rod and Step-Up Spring changes can typically be made in less than five minutes and without removing the carburetor. First, loosen the Step-Up Piston Cover Screws and twist the Step-Up Piston Cover Plates to the side. The Metering Rods and Step-Up Springs can now be removed and replaced if necessary. Be sure to replace the Step-Up Piston Cover Plate, use hand-held nut driver and tighten the Step-Up Piston Cover Screw when finished. **CAUTION:** Do not over-tighten the Step-Up Piston Cover Screws! They should only be tightened to 12 to 17 inch/pounds. Excessive torque will weaken or snap off the screw heads. If this happens, they may fall into the carb causing serious engine damage. If an inch/pound torque wrench is not available, snug the screw until it just touches the plate, then tighten 1/16th turn more.

To replace the Primary or Secondary Metering Jets, first, remove the Metering Rods and Step-Up Springs as outlined in the preceding paragraph. Next, disconnect the Choke Cam Connector Rod, Pump Connector Rod, and Choke Connector Rod (when applicable). Finally, remove the 8 Airhorn Attaching Screws and remove the Airhorn from the carburetor body. A standard flat blade screwdriver can now be used to remove the appropriate Metering Jets. Once the desired Metering Jets have been installed the carburetor may be reassembled by reversing the above procedure.

IDLE MIXTURE

Edelbrock Performer Series, Thunder Series AVS and AVS2 carburetors have conventional Idle Mixture Screws (IMS) that provide a leaner A/F when turned clockwise and richer A/F when turned counter clockwise. The idle air flow is controlled by a conventional screw that opens the Primary Throttles. The following procedure should be used to set the idle mixture and speeds.

1. Fully warm engine and ensure choke is fully open.
2. Air cleaner in place.
3. Set desired speed with the idle speed screw.
4. Adjust the IMS on ONE side to get the maximum possible RPM. Do not go rich beyond the maximum speed point.
5. If the above changed the idle speed more than 40 RPM, then readjust the speed.
6. Adjust the side OPPOSITE of that in Step 4 to get maximum RPM.
7. Reset the speed.
8. Carefully turn each IMS to again get the maximum idle RPM.
9. Go leaner just enough to get a 20 RPM drop in speed.
10. Reset the speed to the desired RPM.
11. This is a Lean-Best Idle Set. Setting richer than this will not improve idle quality or performance, but could tend to foul plugs.

WINTER FUEL IDLE SETS

During the winter months (in most parts of the country) the local fuel will be a "winter" blend that is very volatile, as an assist to cold-engine starting and driveability during warm-up. However, the high volatility has the disadvantage of allowing excessive vaporization of the fuel if the vehicle is operated in a heated area such as a garage. This can result in problems in the idle-set procedures since the carburetor's internal vents will allow this excess vapor to be drawn into the throats and enrichen the mixture. The idle will be erratic and not seem to be able to hold a set. To resolve this type of problem, it is advisable to perform the final settings outdoors after the vehicle has been stabilized with a drive of several miles.

TUNING PROCEDURE

LONG DURATION CAMSHAFT

If the engine has a fairly radical camshaft it may require an excessive amount of throttle opening for idle and/or have low idle vacuum levels. Either condition can lead to poor levels of adjustability and erratic idles.

- Another fix for the above condition is to run as much spark advance as possible at idle. If the distributor is fitted with a vacuum advance unit, connect it directly to manifold vacuum. If you are not able to employ vacuum advance for some reason, then the mechanical curve should have a low limit, which will allow you to use plenty of initial spark advance.
- Measure the manifold vacuum at idle. It is critical that the Step-Up spring vacuum rating is always lower than the manifold vacuum at an idle, with vehicle in neutral. One option in choosing the appropriate Step-Up spring, is by reading vacuum at an idle, and using a Step-Up spring with a rating of half of what the vacuum reading is at an idle (Example: 14" of vacuum at an idle, would equate to a 7" (Pink) Step-Up spring. **Note:** Load-factors come into play as well, such as the vehicles weight, gear ratio, etc. The above example is simply a baseline procedure. If it is below 7" Hg, there is a good chance that the Metering Rods are in the up (rich) position. When combined with a high idle air rate this can cause the Nozzles to discharge fuel at idle. Use a weaker Step-Up Spring (see section on Step-Up calibration) to keep the Rods down at idle. With some cams, a stiffer spring (pink or silver) is necessary. Experimentation is the best way to determine which is best for your application.

CALIBRATING THE WIDE-OPEN-THROTTLE (WOT)

The best place to perform your WOT calibration is on a chassis dyno. If one is not available then consider a safe, legal driving space, such as a drag strip where you are given E.T. and MPH data.

1. Select an RPM Range to use in evaluating the WOT power. As a rule, use the highest 50 percent of the real power band. If your engine makes good power up to 5000 RPM, then 2500-5000 is a good range. If peak power is at 6500, then 3500-6500 would be a good pick. Be sure not to select RPMs that are higher than the engine's useful power band.
2. Accelerate at WOT from 1000 RPM below the range you have elected to a few hundred over the range. Time the acceleration with a stop-watch. Be sure to time only the interval while the engine is sweeping through the selected range. Make enough timed accelerations to get a good average that is not affected by wind or grade.
3. Refer to the Calibration Reference Chart for your model. Find the richest Power Mode (Primary Metering) change you can make without changing a Jet — a Rod change only. This will probably be 2 stages (8%) rich.
4. Change to the indicated Rods. Perform timed acceleration #2. Compare the times. Do not be surprised if there is no difference.
5. Compare the results of timed acceleration #2 to the base calibration and refer to the following section that best describes your situation:

CASE 1: FASTER THAN BASE CALIBRATION

Change Secondaries jet 2 stages richer and perform acceleration test #3.

- If test #3 is the same as #2, you're done.
- If test #3 is slower than #2, change to 1 stage rich for the Primary and Secondary jet and you're done.
- If test #3 is still faster than #2, go to 3 stages rich Primary and Secondary jet and keep going richer until there is no change (or slower) in the times. Stay at the first "no change" level, so that you stay with the richer of any two levels of calibration that have the same power.

TUNING PROCEDURE

CASE 2: SLOWER THAN BASE CALIBRATION

Go to 1 stage lean Primaries and 1 lean Secondaries jet and perform acceleration test #3.

- If test #3 is the same as base calibration, go back to the base calibration.
- If test #3 is faster than base calibration, go to 2 stages lean on both the Primaries and the Secondaries jet. Keep going in the lean direction until there is no change or slower then back up 1 stage richer, so that you stay with the richer of any two levels of calibration that have the same power.

CASE 3: SAME AS BASE CALIBRATION

Do not be surprised. Change back to base calibration.

CALIBRATING THE PART-THROTTLE

The Metering Rod feature used in the Edelbrock carburetor allows easy calibration of the part-throttle without change to the WOT metering.

- Cruise Mode: The power output is low, as in a steady cruise light acceleration. Manifold Vacuum is high and the Metering Rods are down in the lean position.
- Power Mode: The power output is high, as in a heavy but not wide-open acceleration. Manifold Vacuum is low and the Rods are up in the rich position.

The Step-Up function modulates the Rods between the Cruise and Power positions.

The part-throttle calibration is more “individualized” than is the Wide-Open-Throttle (WOT). It is not measured by absolute numbers, but reflects the driver’s feel for a particular combination.

Carefully evaluate the driveability with the carburetor at the calibration level determined from the WOT exercise. Drive at a variety of engine speeds and throttle openings looking for any flat spots or lean/surge conditions.

CRUISE MODE

If there are any surge or flat spot conditions in the steady speed cruises or light accelerations, a lean condition probably exists. Consult the Calibration Reference Chart and change to 1 stage rich in the Cruise Mode. If it gets better, but not completely fixed, keep going in the rich direction. The Calibration Reference Chart will give you Rod and Jet combinations that are directionally correct or you may choose your own.

If the light throttle is satisfactory, trying going 1 stage lean in the Cruise Mode. If there are still no problems with surge or other indications of lean metering, do not hesitate to go to 2 stages lean in the Cruise Mode. A lean Cruise Mode has advantages in fuel economy and keeping the plugs clean. Keep going until you begin to notice driveability problems and then back up 1 stage.

POWER MODE

Accelerations at part-throttle with low manifold vacuum (less than about 5" Hg on a vacuum gauge) are metered by the Power Mode. Avoid calibrating this portion of the engine’s operating range too lean as spark knock (detonation) and piston/valve burning can occur. If this mode has any lean driveability symptoms (surge or flat spots), it is too lean and should be re-calibrated at least 1 stage richer.

TUNING PROCEDURE

CALIBRATING THE POWER MODE STAGING

The Step-Up function, which moves the Metering Rod to the Power Mode, is controlled by the Step-Up Spring. The base calibration has a spring which “stages” rich at 5" Hg. (5" Hg is considered the transition area due to the fact that all Edelbrock carbs – other than the #1406 which uses a 4" Hg step-up spring – all use a 5" Hg rated step-up spring.)

If your vehicle has a mid-throttle driveability problem that is encountered as the throttle is gradually opened, but then goes away upon further opening, it may be possible to eliminate the lean spot by using a stronger Step-Up Spring. The available Step-Up Springs are listed in the following chart along with their respective “staging” point.

Spring Color	Blue	Yellow	Orange	Pink	Plain
Staging Vacuum ("Hg)	3"	4"	5"	7"	8"

It is best to select a new spring on the basis of vacuum readings, but in the absence of a gauge, try the strongest spring (highest vacuum rating) to see if the problem goes away. If the drive problem is cured by the strong spring, try the next weakest spring as well. If the strong one does not help, then the calibration problem is related to the A/F metering stage of either the Cruise or Power Modes. Use the Calibration Reference Chart to help select another combination. **A complete set of these springs is available separately as Edelbrock #1464 and are also included with all calibration kits, see page 33.**

CALIBRATING THE PUMP

If you encounter any hesitations or stumbles that do not seem to be related to the basic metering or have not responded to changes in the basic metering, move the pump drive link to one of the holes closer to the carburetor body. This will increase the stroke length of the plunger and result in more pump delivery.

FLOAT ADJUSTMENT

To properly adjust the floats in the EPS, AVS and AVS2 carburetors, two procedures must be followed. First, invert the airhorn cover while holding the airhorn gasket in place. There should be 7/16" between the airhorn gasket and the center, half way under the middle of the float (see figure 1). To adjust the float level, bend the float lever until the recommended level is attained. DO NOT press the needle into the seat when adjusting the float lever. Next, you should check the float drop (see figure 2). Hold the airhorn upright and let the floats hang down. There should be 15/16" to 1" between the airhorn gasket and the top of the outer end of the float. To adjust the float drop, bend the tab on the back until the recommended float drop is attained.

CHOKE ADJUSTMENT

To adjust the fast idle linkage (Figure 3) place the fast idle screw **A** between the two notches on the cam. Close the choke valve as far as possible without forcing it. The dimension **C** should be 3/64" between the choke valve and the air horn. To adjust bend rod **C**.

Fast idle may be adjusted to manufacturers specifications (usually 1500 rpm) during normal choke cold operation. The fast idle screw **A** can be adjusted with engine off and throttle held open to allow screw head access. Recheck fast idle speed after each adjustment.

The length of time during which the choke will stay closed is determined by the position of the choke cap. As the choke cap is turned clockwise the choke will stay closed longer. To properly set the choke turn the choke cap to the leanest notch on the choke housing, tighten the choke housing retaining screws, and run the engine until normal operating temperature is reached. With the engine running, slowly turn the choke cap clockwise until the choke valve begins to close. Now turn the choke housing one notch counterclockwise (LEAN) and tighten the choke housing retaining screws. **Periodic readjustment of the choke will be required as the temperature changes throughout the year.** After each adjustment verify that the choke valve opens fully after the engine is warm.

TUNING PROCEDURE

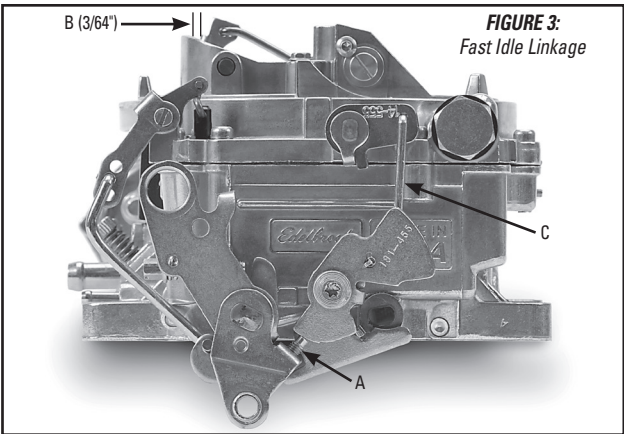
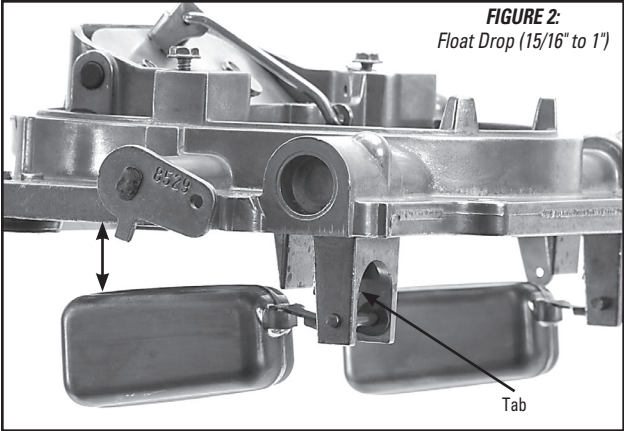
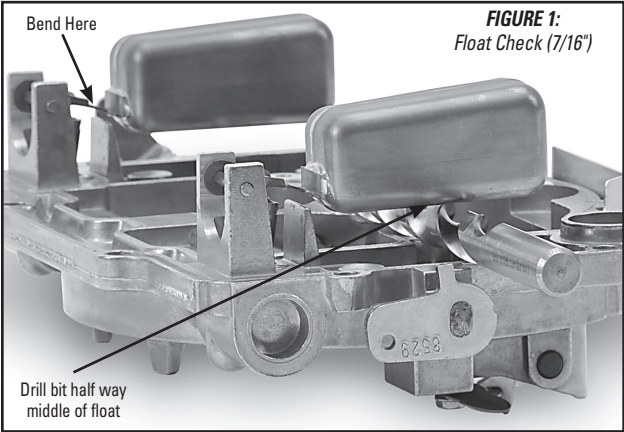

TUNING PROCEDURE

CARBURETOR SPECIFICATIONS - ALL MODELS

Carb Part No.	CFM	Main Jet Primary	Main Jet Secondary	Metering Rod (Primary only)	Step-Up Spring	Needle & Seat	Float Height
#1403	500	.086"	.095"	.065" x .052"	orange (5")	.0935"	7/16"
#1404	500	.086"	.095"	.065" x .052"	orange (5")	.0935"	7/16"
#1405	600	.100"	.095"	.070" x .047"	orange (5")	.0935"	7/16"
#1406	600	.098"	.095"	.075" x .047"	yellow (4")	.0935"	7/16"
#1407	750	.113"	.107"	.071" x .047"	orange (5")	.0935"	7/16"
#1409*	600	.098"	.101"	.068" x .047"	orange (5")	.0935"	7/16"
#1410*	750	.113"	.107"	.071" x .047"	orange (5")	.0935"	7/16"
#1411	750	.110"	.107"	.075" x .047"	orange (5")	.0935"	7/16"
#1412	800	.113"	.101"	.075" x .047"	orange (5")	.0935"	7/16"
#1413	800	.113"	.101"	.071" x .047"	orange (5")	.0935"	7/16"
#1801/#1802	500	.086"	.095"	.065" x .052"	orange (5")	.0935"	7/16"
#1803	500	.086"	.077"	.065" x .057"	orange (5")	.0935"	7/16"
#1804	500	.086"	.077"	.065" x .052"	orange (5")	.0935"	7/16"
#1805	650	.095"	.098"	.068" x .047"	orange (5")	.0935"	7/16"
#1806	650	.095"	.098"	.068" x .047"	orange (5")	.0935"	7/16"
#1812/#1813	800	.113"	.101"	.068" x .047"	orange (5")	.0935"	7/16"
#1825/#1826	650	.095"	.098"	.065" x .047"	orange (5")	.0935"	7/16"
#1901/#1902	500	.095"	.095"	.070" x .052"	orange (5")	.0935"	7/16"
#1903/#1904	500	.095"	.077"	.070" x .052"	orange (5")	.0935"	7/16"
#1905/#1906	650	.101"	.098"	.070" x .037"	orange (5")	.0935"	7/16"
#1912/#1913	800	.104"	.104"	.065" x .052"	orange (5")	.0935"	7/16"

*Carburetor is certified to meet U.S. Coast Guard Requirements

OFF-ROAD

Although Edelbrock carburetors are not calibrated with hill climbing and other extreme off-road operation in mind, it can be made to perform superbly by substituting Edelbrock #1465 spring loaded needle and seat for the original needle and seat. The spring loaded needle and seat act like a shock absorber, reducing the possibility of flooding during off-road operation. After installation of the new needle and seat you must reset the float level to 7/16" and drop the float drop to between 15/16" and 1" as outlined in "FLOAT ADJUSTMENT".

HIGH FUEL FLOW

When evidence of fuel starvation exists, first ensure that proper pressure (4-5 psi minimum) is maintained at WOT. If proper fuel pressure is supplied and fuel starvation still exists, it may be necessary to change the needle and seat to a larger size (#1466). Do not make this change unless absolutely required, as the smaller inlet is preferred for proper fuel control under most conditions.

HIGH ALTITUDE

Altitude has a direct effect on the operation of most carburetors. As the altitude increases, the air becomes less dense so a carburetor, originally calibrated at low altitude (sea level), delivers too much fuel and the engine runs richer. If the preceding tuning procedure is performed, then a proper high altitude calibration will result. If the vehicle was calibrated at lower altitude, however, and is to be driven at high altitude temporarily, it is not necessary to repeat the complete calibration procedure. Instead, use the rule of: "2% leaner per 1500 feet" and the Calibration Reference Chart for your model carburetor. For example, with a #1405 at baseline calibration (location #1 on the chart) and intended operation at 6000 ft. altitude, you would want 6000 divided by 1500 x 2% = 8% leaner calibration. That would be location #24 on the chart which would require only a rod and jet change.

TUNING PROCEDURE

Float Drop	Pump Drive Link Location	Accelerator Pump Nozzle Diameter	Venturi Diameter Primaries	Venturi Diameter Secondaries	Throttle Bore Diameter Primaries	Throttle Bore Diameter Secondary
1.00"	middle hole	.028"	1-9/16"	1-9/16"	1-7/16"	1-11/16"
1.00"	middle hole	.028"	1-3/16"	1-9/16"	1-7/16"	1-11/16"
1.00"	middle hole	.028"	1-3/16"	1-9/16"	1-7/16"	1-11/16"
1.00"	middle hole	.031"	1-3/16"	1-9/16"	1-7/16"	1-11/16"
1.00"	top hole	.035"	1-7/16"	1-9/16"	1-11/16"	1-11/16"
1.00"	middle hole	.028"	1-3/16"	1-9/16"	1-7/16"	1-11/16"
1.00"	top hole	.035"	1-7/16"	1-9/16"	1-11/16"	1-11/16"
1.00"	top hole	.035"	1-7/16"	1-9/16"	1-11/16"	1-11/16"
1.00"	top hole	.035"	1-17/32"	1-5/8"	1-3/4"	1-3/4"
1.00"	top hole	.035"	1-17/32"	1-5/8"	1-3/4"	1-3/4"
1.00"	middle hole	.028"	1-3/16"	1-9/16"	1-7/16"	1-11/16"
1.00"	middle hole	.028"	1-3/16"	1-9/16"	1-7/16"	1-11/16"
1.00"	middle hole	.028"	1-3/16"	1-9/16"	1-7/16"	1-11/16"
1.00"	middle hole	.031"	1-3/16"	1-5/8"	1-7/16"	1-3/4"
1.00"	middle hole	.031"	1-3/16"	1-5/8"	1-7/16"	1-3/4"
1.00"	top hole	.035"	1-17/32"	1-5/8"	1-3/4"	1-3/4"
1.00"	middle hole	.031"	1-3/16"	1-5/8"	1-7/16"	1-3/4"
1.00"	middle hole	.028"	1-3/16"	1-9/16"	1-7/16"	1-11/16"
1.00"	middle hole	.028"	1-3/16"	1-9/16"	1-7/16"	1-11/16"
1.00"	middle hole	.031"	1-3/16"	1-5/8"	1-7/16"	1-3/4"
1.00"	top hole	.035"	1-17/32"	1-5/8"	1-3/4"	1-3/4"

SPECIAL CALIBRATIONS

The preceding calibrations and adjustments apply to carburetors used in general street applications. In the following extreme instances, special calibration procedures may need to be followed.

BLENDED FUELS

Typically, two types of blended fuels are available: Gasohol and gasahol. Gasohol is a blend of not more than 10% ethanol and gasoline. As long as there is no more than 10% ethanol mixed with the gasoline your carburetor will function properly. As the percentage of ethanol climbs above 10%, a richer A/F ratio will be required. Also, because gasahol is more volatile than gasoline, hard hot starting and poor hot weather driveability may result. Gasahol can be a blend of either ethanol, methanol or other alcohol with gasoline. Methanol blended fuel should not be used in your Edelbrock Performer Series carburetor as it will cause corrosion of the fuel system components. It can also cause rapid failure of seals, gaskets, diaphragms and pump plungers. Always check to see if you are using a blended fuel. Although the pump may not indicate the fuel is blended, it is always advisable to verify the type of fuel the station carries.

Under no circumstance should E85 fuel be used with Edelbrock carburetors.

BLOWN ENGINES

Two model #1405 carburetors should be used on engines with positive displacement superchargers, such as GMC 6-71 blowers or equivalent. The following calibration changes make an excellent starting point: Primary Jets - .101" (#1429); Secondary Jets - .101" (#1429); Metering Rods - .070" x .042" (#1450); Step-up Piston Springs - 5" (orange, stock); Needle & Seat assemblies - .110" (#1466). This calibration has been tested on engines ranging in size from 350 c.i.d. Chevy's to 440 c.i.d. Chrysler's with good results.

TROUBLESHOOTING CHART

POSSIBLE SOLUTION	SYMPTOMS						
	Carb Doesn't Adjust Properly	Carb Floods	Fuel Leaks at Shaft	Internal Fuel Leak	Misses or Surges	Stumbles or Loads Up	
Check for air leaks. Make sure carburetor and manifold gaskets seal properly. All outlets must be plugged or connected.	✓				✓		
Check ignition system. Replace parts as necessary. Adjust timing to proper specifications.	✓				✓		
Check choke adjustment. See page 7-8.					✓	✓	
Change carb fuel filter and/or in-line fuel filter.		✓				✓	
Too lean. See Tuning Procedure.					✓		
Check float level and drop. See page 7-8.		✓	✓			✓	
Check idle mixture screw adjustment. See page 4.	✓						
Too rich.							✓
Increase accelerator pump stroke. Pump squirter size change may be needed. See page 14.							✓
Off-road vehicle may need spring-loaded needle and seat kit. See pg. 9.		✓	✓				
Check for dirt or metal in needles and seats. Needles and seats may need replacement. See page 36.		✓		✓			
Check for dirt blocking the low speed circuit. Clean unit and apply air pressure. Install in-line fuel filter.	✓						
Check floats for leakage. Replace if necessary.		✓		✓			
Check air horn gasket. Replace if deterioration or breakage is present.		✓		✓			
Fuel is boiling due to excessive under hood temperature. See page 36.			✓				
Fuel pressure too high. Fuel regulator may be needed.		✓		✓			
Fuel pressure too low. Check fuel system.					✓		
Check secondary latching device and rod for proper movement.							
Lower float level from 7/16" to 1/2". See page 7.							

TROUBLESHOOTING CHART

	Engine Won't Idle	Rough Idle	Backfires	Bogs	Hard Starting	Lack of Power	Pinging at Moderate Cruise Off Just Idle	Engine Stalls on Hard Braking	Low Fuel Economy
	✓	✓	✓	✓		✓	✓		✓
	✓	✓	✓		✓		✓		✓
	✓	✓	✓			✓			✓
					✓	✓	✓		
				✓		✓	✓		
								✓	✓
	✓	✓							✓
				✓					✓
						✓			
									✓
	✓						✓		✓
								✓	✓
					✓				✓
								✓	✓
						✓			
						✓			
								✓	

CALIBRATION REFERENCE CHART

PRIMARY METERING #1403/#1404/#1801/#1802

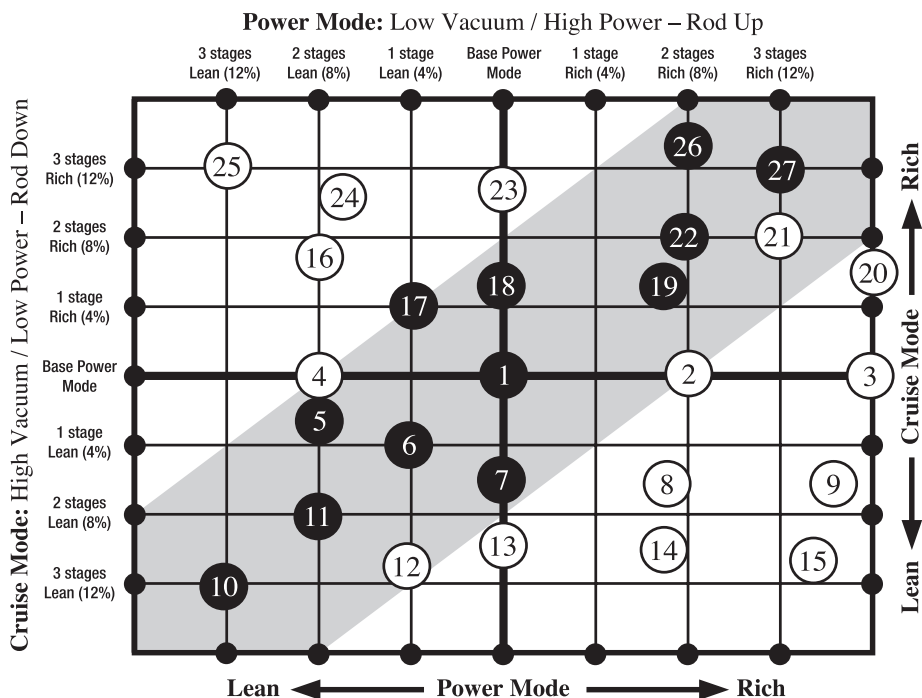

- 1 Stock Calibration
- # Numbers in black are the steps obtainable using **Calibration Kit #1486** plus the stock jets and metering rods.
- # Numbers in white are the steps obtainable using jet and rod combinations shown on the following page.

- Step 1 Select the combination of Cruise Mode and Power Mode fuel-metering stages desired for your calibration. Normal calibration changes will be within the gridded diagonal area. That is, Cruise and Power mode changes should be in the same direction (either richer or leaner) and usually by the same amount.
- Step 2 Find the number that is nearest your desired combination. This is your Calibration Reference Number.
- Step 3 Go to the next page. Find the Calibration Reference Number you have just selected in Step 2. Listed will be the Main Jet and Metering Rod required to achieve the desired fuel metering for the Primaries.

ROD/JET REFERENCE CHART

Ref #	Main Jet	Metering Rod	Change from Base
1	#1423 (.086")	#1460 (.065" x .052")	none-stock calibration
2	#1423 (.086")	#1455 (.065" x .047")	Rod
3	#1423 (.086")	#1444 (.065" x .037")	Rod
4	#1423 (.086")	#1461 (.065" x .057")	Rod
5	#1422 (.083")	#1441 (.062" x .052")	Rod & Jet
6	#1423 (.086")	#1463 (.067" x .055")	Rod
7	#1423 (.086")	#1448 (.068" x .052")	Rod
8	#1423 (.086")	#1447 (.068" x .047")	Rod
9	#1423 (.086")	#1446 (.068" x .042")	Rod
10	#1422 (.083")	#1463 (.067" x .055")	Rod & Jet
11	#1422 (.083")	#1460 (.065" x .052")	Jet
12	#1422 (.083")	#1462 (.067" x .049")	Rod & Jet
13	#1423 (.086")	#1452 (.070" x .052")	Rod
14	#1423 (.086")	#1451 (.070" x .047")	Rod
15	#1423 (.086")	#1450 (.070" x .042")	Rod
16	#1422 (.083")	#1438 (.058" x .052")	Rod & Jet
17	#1422 (.083")	#1437 (.057" x .049")	Rod & Jet
18	#1423 (.086")	#1441 (.062" x .052")	Rod
19	#1423 (.086")	#1443 (.063" x .047")	Rod
20	#1423 (.086")	#1442 (.063" x .037")	Rod
21	#1424 (.089")	#1445 (.065" x .047")	Rod & Jet
22	#1424 (.089")	#1460 (.065" x .052")	Jet
23	#1423 (.086")	#1439 (.060" x .052")	Rod
24	#1423 (.086")	#1440 (.060" x .057")	Rod
25	#1422 (.083")	#1436 (.055" x .055")	Rod & Jet
26	#1424 (.089")	#1441 (.062" x .052")	Rod & Jet
27	#1424 (.089")	#1443 (.063" x .047")	Rod & Jet

SECONDARY METERING

The factory calibration jet is shown in the center column. For leaner or richer calibration use the jet # indicated in the appropriate column.

3 Stages Lean (12%)	2 Stages Lean (8%)	1 Stage Lean (4%)	SECONDARY Stock Calibration	1 Stage Rich (4%)	2 Stages Rich (8%)	3 Stages Rich (12%)
Jet #1423 (.086")	Jet #1424 (.089")	Jet #1425 (.092")	Jet #1426 (.095")	Jet #1427 (.098")	Jet #1429 (.101")	Jet #1430 (.104")

Main Jet I.D.—All Edelbrock jets have "120-" prefix. The last three digits minus 300 = actual jet size.

Examples: 120-386 = .086" jet (Edelbrock p/n 1423).
120-401 = .101" jet (Edelbrock p/n 1429).

CALIBRATION REFERENCE CHART

PRIMARY METERING #1405

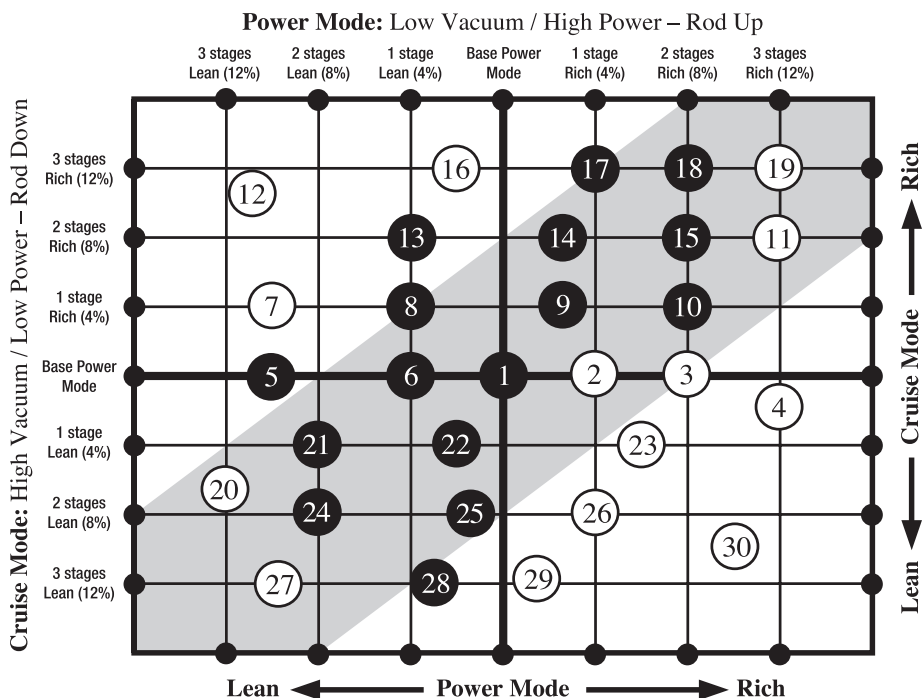

- 1** Stock Calibration
- #** Numbers in black are the steps obtainable using **Calibration Kit #1479** plus the stock jets and metering rods.
- #** Numbers in white are the steps obtainable using jet and rod combinations shown on the following page.

- Step 1 Select the combination of Cruise Mode and Power Mode fuel-metering stages desired for your calibration. Normal calibration changes will be within the gridded diagonal area. That is, Cruise and Power mode changes should be in the same direction (either richer or leaner) and usually by the same amount.
- Step 2 Find the number that is nearest your desired combination. This is your Calibration Reference Number.
- Step 3 Go to the next page. Find the Calibration Reference Number you have just selected in Step 2. Listed will be the Main Jet and Metering Rod required to achieve the desired fuel metering for the Primaries.

ROD/JET REFERENCE CHART

Ref #	Main Jet	Metering Rod	Change from Base
1	#1428 (.100")	#1451 (.070" x .047")	none - stock calibration
2	#1428 (.100")	#1450 (.070" x .042")	Rod
3	#1428 (.100")	#1449 (.070" x .037")	Rod
4	#1430 (.104")	#1458 (.075" x .037")	Rod & Jet
5	#1427 (.098")	#1448 (.068" x .052")	Rod & Jet
6	#1428 (.100")	#1452 (.070" x .052")	Rod
7	#1427 (.098")	#1445 (.065" x .047")	Rod & Jet
8	#1428 (.100")	#1448 (.068" x .052")	Rod
9	#1428 (.100")	#1446 (.068" x .042")	Rod
10	#1430 (.104")	#1459 (.075" x .047")	Rod & Jet
11	#1430 (.104")	#1455 (.073" x .042")	Rod & Jet
12	#1427 (.098")	#1441 (.062" x .052")	Rod & Jet
13	#1429 (.101")	#1448 (.068" x .052")	Rod & Jet
14	#1430 (.104")	#1457 (.073" x .052")	Rod & Jet
15	#1430 (.104")	#1456 (.073" x .047")	Rod & Jet
16	#1428 (.100")	#1445 (.065" x .047")	Rod
17	#1430 (.104")	#1452 (.070" x .052")	Rod & Jet
18	#1430 (.104")	#1451 (.070" x .047")	Jet
19	#1430 (.104")	#1450 (.070" x .042")	Rod & Jet
20	#1426 (.095")	#1445 (.065" x .047")	Rod & Jet
21	#1427 (.098")	#1452 (.070" x .052")	Rod & Jet
22	#1428 (.100")	#1457 (.073" x .052")	Rod
23	#1428 (.100")	#1455 (.073" x .042")	Rod
24	#1427 (.098")	#1457 (.073" x .052")	Rod & Jet
25	#1428 (.100")	#1459 (.075" x .047")	Rod
26	#1427 (.098")	#1449 (.070" x .037")	Rod & Jet
27	#1426 (.095")	#1446 (.068" x .042")	Rod & Jet
28	#1427 (.098")	#1456 (.073" x .047")	Rod & Jet
29	#1427 (.098")	#1455 (.073" x .042")	Rod & Jet
30	#1429 (.101")	#1458 (.075" x .037")	Rod & Jet

SECONDARY METERING

The factory calibration jet is shown in the center column. For leaner or richer calibration use the jet # indicated in the appropriate column.

3 Stages Lean (12%)	2 Stages Lean (8%)	1 Stage Lean (4%)	SECONDARY Stock Calibration	1 Stage Rich (4%)	2 Stages Rich (8%)	3 Stages Rich (12%)
Jet #1423 (.086")	Jet #1424 (.089")	Jet #1425 (.092")	Jet #1426 (.095")	Jet #1427 (.098")	Jet #1429 (.101")	Jet #1430 (.104")

Main Jet I.D.—All Edelbrock jets have "120-" prefix. The last three digits minus 300 = actual jet size.

Examples:

120-398 = .098" jet (Edelbrock p/n 1427).

120-400 = .100" jet (Edelbrock p/n 1428).

CALIBRATION REFERENCE CHART

PRIMARY METERING #1406

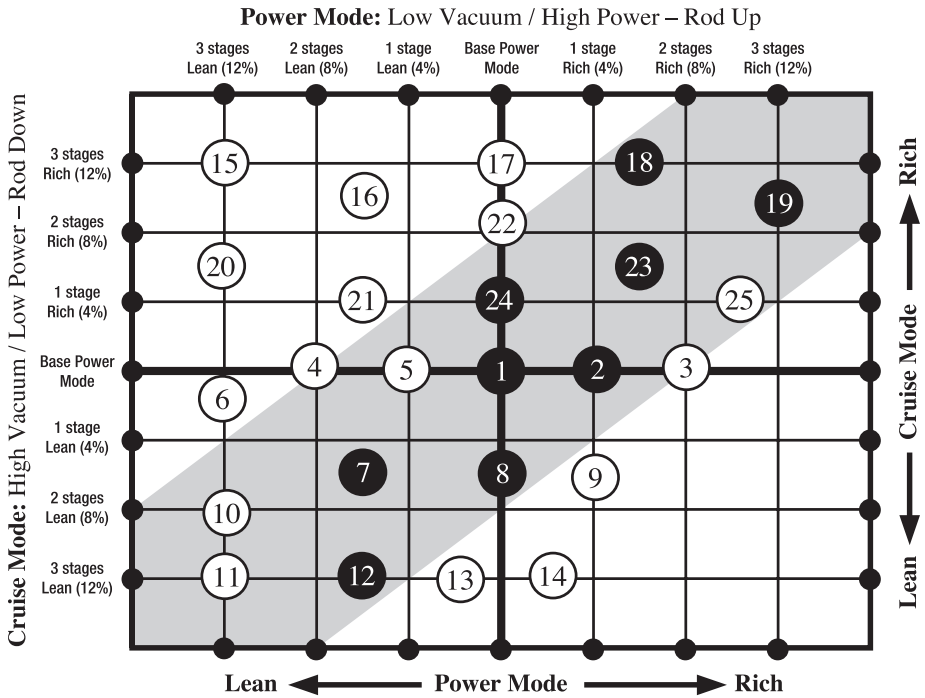

1 Stock Calibration

Numbers in black are the steps obtainable using **Calibration Kit #1487** plus the stock jets and metering rods.

Numbers in white are the steps obtainable using jet and rod combinations shown on the following page.

- Step 1 Select the combination of Cruise Mode and Power Mode fuel-metering stages desired for your calibration. Normal calibration changes will be within the gridded diagonal area. That is, Cruise and Power mode changes should be in the same direction (either richer or leaner) and usually by the same amount.
- Step 2 Find the number that is nearest your desired combination. This is your Calibration Reference Number.
- Step 3 Go to the next page. Find the Calibration Reference Number you have just selected in Step 2. Listed will be the Main Jet and Metering Rod required to achieve the desired fuel metering for the Primaries.

ROD/JET REFERENCE CHART

Ref #	Main Jet	Metering Rod	Change from Base
1	#1427 (.098")	#1459 (.075" x .047")	none - stock calibration
2	#1426 (.095")	#1449 (.070" x .037")	Rod & Jet
3	#1427 (.098")	#1458 (.075" x .037")	Rod
4	#1425 (.092")	#1446 (.068" x .042")	Rod & Jet
5	#1426 (.095")	#1453 (.071" x .047")	Rod & Jet
6	#1425 (.092")	#1447 (.068" x .047")	Rod & Jet
7	#1426 (.095")	#1456 (.073" x .047")	Rod & Jet
8	#1426 (.095")	#1455 (.073" x .042")	Rod & Jet
9	#1426 (.095")	#1454 (.073" x .037")	Rod & Jet
10	#1425 (.092")	#1451 (.070" x .047")	Rod & Jet
11	#1425 (.092")	#1453 (.071" x .047")	Rod & Jet
12	#1426 (.095")	#1459 (.075" x .047")	Jet
13	#1425 (.092")	#1449 (.070" x .037")	Rod & Jet
14	#1426 (.095")	#1458 (.075" x .037")	Rod & Jet
15	#1426 (.095")	#1448 (.068" x .052")	Rod & Jet
16	#1426 (.095")	#1447 (.068" x .047")	Rod & Jet
17	#1427 (.098")	#1453 (.071" x .047")	Rod
18	#1429 (.101")	#1459 (.075" x .047")	Jet
19	#1427 (.098")	#1449 (.070" x .037")	Rod
20	#1425 (.092")	#1445 (.065" x .047")	Rod & Jet
21	#1426 (.095")	#1451 (.070" x .047")	Rod & Jet
22	#1426 (.095")	#1446 (.068" x .042")	Rod & Jet
23	#1427 (.098")	#1455 (.073" x .042")	Rod
24	#1427 (.098")	#1456 (.073" x .047")	Rod
25	#1427 (.098")	#1454 (.073" x .037")	Rod

SECONDARY METERING

The factory calibration jet is shown in the center column. For leaner or richer calibration use the jet # indicated in the appropriate column.

3 Stages Lean (12%)	2 Stages Lean (8%)	1 Stage Lean (4%)	SECONDARY Stock Calibration	1 Stage Rich (4%)	2 Stages Rich (8%)	3 Stages Rich (12%)
Jet #1423 (.086")	Jet #1424 (.089")	Jet #1425 (.092")	Jet #1426 (.095")	Jet #1427 (.098")	Jet #1429 (.101")	Jet #1430 (.104")

Main Jet I.D.—All Edelbrock jets have "120-" prefix. The last three digits minus 300 = actual jet size.

Examples: 120-398 = .098" jet (Edelbrock p/n 1427).
120-401 = .101" jet (Edelbrock p/n 1429).

CALIBRATION REFERENCE CHART

PRIMARY METERING #1407/#1410

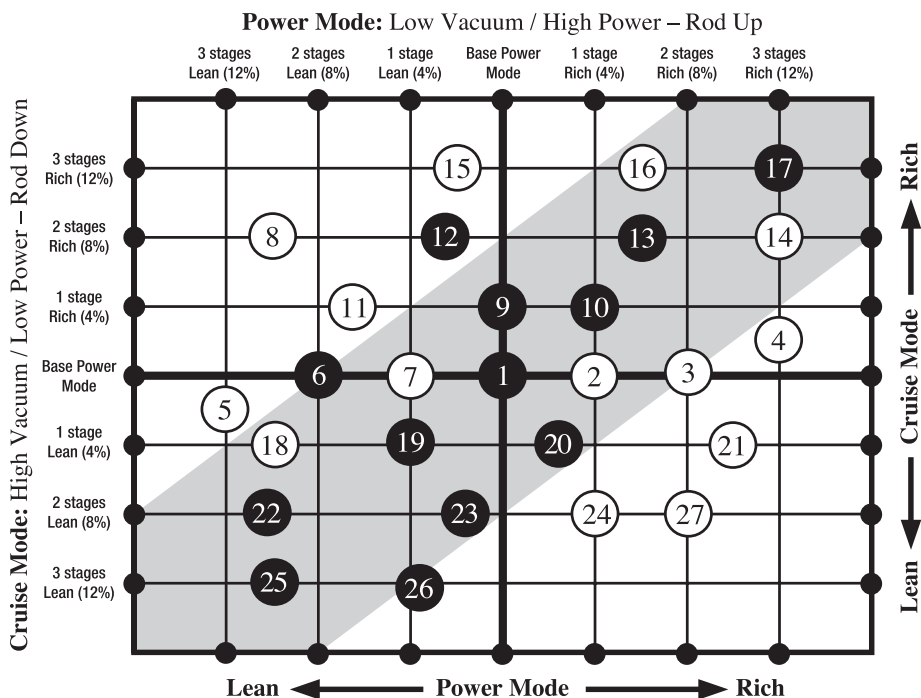

- 1 Stock Calibration
- # Numbers in black are the steps obtainable using **Calibration Kit #1480** plus the stock jets and metering rods.
- # Numbers in white are the steps obtainable using jet and rod combinations shown on the following page.

- Step 1 Select the combination of Cruise Mode and Power Mode fuel-metering stages desired for your calibration. Normal calibration changes will be within the gridded diagonal area. That is, Cruise and Power mode changes should be in the same direction (either richer or leaner) and usually by the same amount.
- Step 2 Find the number that is nearest your desired combination. This is your Calibration Reference Number.
- Step 3 Go to the next page. Find the Calibration Reference Number you have just selected in Step 2. Listed will be the Main Jet and Metering Rod required to achieve the desired fuel metering for the Primaries.

ROD/JET REFERENCE CHART

Ref #	Main Jet	Metering Rod	Change from Base
1	#1433 (.113")	#1453 (.071" x .047")	none - stock calibration
2	#1433 (.113")	#1450 (.070" x .042")	Rod
3	#1433 (.113")	#1449 (.070" x .037")	Rod
4	#1434 (.116")	#1454 (.073" x .037")	Rod & Jet
5	#1431 (.107")	#1443 (.063" x .047")	Rod & Jet
6	#1432 (.110")	#1445 (.065" x .047")	Rod & Jet
7	#1433 (.113")	#1452 (.070" x .052")	Rod
8	#1432 (.110")	#1441 (.062" x .052")	Rod & Jet
9	#1433 (.113")	#1447 (.068" x .047")	Rod
10	#1434 (.116")	#1456 (.073" x .047")	Rod & Jet
11	#1432 (.110")	#1443 (.063" x .047")	Rod & Jet
12	#1433 (.113")	#1445 (.065" x .047")	Rod
13	#1434 (.116")	#1453 (.071" x .047")	Jet
14	#1434 (.116")	#1449 (.070" x .037")	Rod & Jet
15	#1433 (.113")	#1443 (.063" x .047")	Rod
16	#1433 (.113")	#1442 (.063" x .037")	Rod
17	#1434 (.116")	#1444 (.065" x .037")	Rod & Jet
18	#1432 (.110")	#1452 (.070" x .052")	Rod & Jet
19	#1433 (.113")	#1457 (.073" x .052")	Rod
20	#1433 (.113")	#1456 (.073" x .047")	Rod
21	#1433 (.113")	#1454 (.073" x .037")	Rod
22	#1431 (.107")	#1445 (.065" x .047")	Rod & Jet
23	#1431 (.107")	#1444 (.065" x .037")	Rod & Jet
24	#1432 (.110")	#1449 (.070" x .037")	Rod & Jet
25	#1431 (.107")	#1447 (.068" x .047")	Rod & Jet
26	#1432 (.110")	#1456 (.073" x .047")	Rod & Jet
27	#1432 (.110")	#1454 (.073" x .037")	Rod & Jet

SECONDARY METERING

The factory calibration jet is shown in the center column. For leaner or richer calibration use the jet # indicated in the appropriate column.

3 Stages Lean (12%)	2 Stages Lean (8%)	1 Stage Lean (4%)	SECONDARY Stock Calibration	1 Stage Rich (4%)	2 Stages Rich (8%)	3 Stages Rich (12%)
Jet #1427 (.098")	Jet #1429 (.101")	Jet #1430 (.104")	Jet #1431 (.107")	Jet #1432 (.110")	Jet #1433 (.113")	Jet #1434 (.116")

Main Jet I.D.—All Edelbrock jets have "120-" prefix. The last three digits minus 300 = actual jet size.

Examples: 120-398 = .098" jet (Edelbrock p/n 1427).
120-413 = .113" jet (Edelbrock p/n 1433).

CALIBRATION REFERENCE CHART

PRIMARY METERING #1409

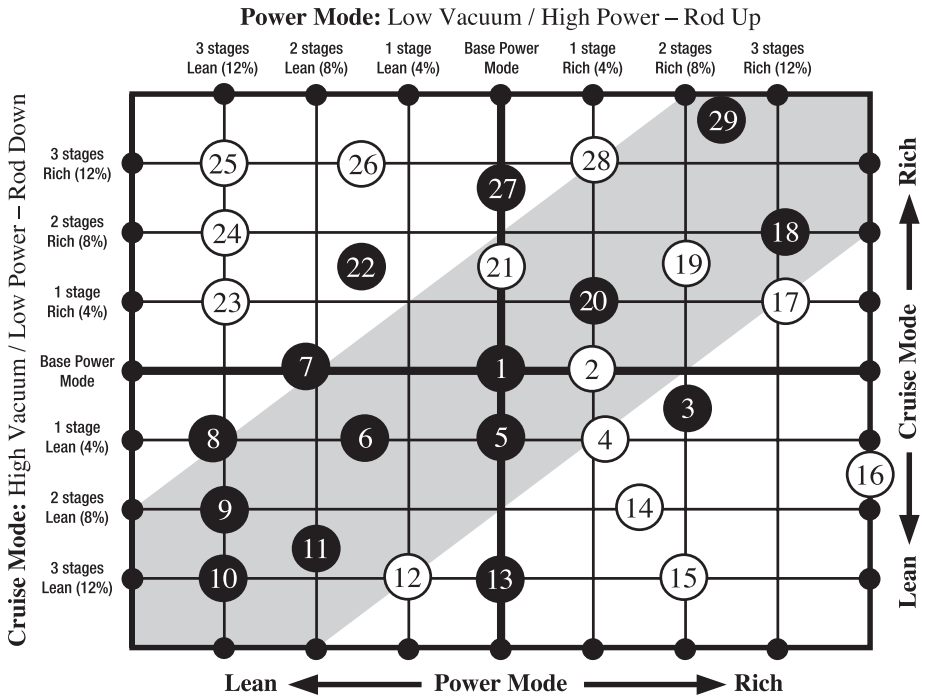

- 1 Stock Calibration
- # Numbers in black are the steps obtainable using **Calibration Kit #1488** plus the stock jets and metering rods.
- # Numbers in white are the steps obtainable using jet and rod combinations shown on the following page.

- Step 1 Select the combination of Cruise Mode and Power Mode fuel-metering stages desired for your calibration. Normal calibration changes will be within the gridded diagonal area. That is, Cruise and Power mode changes should be in the same direction (either richer or leaner) and usually by the same amount.
- Step 2 Find the number that is nearest your desired combination. This is your Calibration Reference Number.
- Step 3 Go to the next page. Find the Calibration Reference Number you have just selected in Step 2. Listed will be the Main Jet and Metering Rod required to achieve the desired fuel metering for the Primaries.

ROD/JET REFERENCE CHART

Ref #	Main Jet	Metering Rod	Change from Base
1	#1427 (.098")	#1447 (.068" x .047")	none - stock calibration
2	#1427 (.098")	#1446 (.068" x .042")	Rod
3	#1429 (.101")	#1456 (.073" x .047")	Rod & Jet
4	#1427 (.098")	#1450 (.070" x .042")	Rod
5	#1427 (.098")	#1451 (.070" x .047")	Rod
6	#1427 (.098")	#1452 (.070" x .052")	Rod
7	#1426 (.095")	#1443 (.063" x .047")	Rod & Jet
8	#1426 (.095")	#1460 (.065" x .052")	Rod & Jet
9	#1425 (.092")	#1443 (.063" x .047")	Rod & Jet
10	#1426 (.095")	#1452 (.070" x .052")	Rod & Jet
11	#1426 (.095")	#1447 (.068" x .047")	Jet
12	#1425 (.092")	#1444 (.065" x .037")	Rod & Jet
13	#1427 (.098")	#1456 (.073" x .047")	Rod
14	#1429 (.101")	#1459 (.075" x .047")	Rod & Jet
15	#1427 (.098")	#1454 (.073" x .037")	Rod
16	#1429 (.101")	#1458 (.075" x .037")	Rod & Jet
17	#1430 (.104")	#1459 (.075" x .047")	Rod & Jet
18	#1430 (.104")	#1456 (.073" x .047")	Rod & Jet
19	#1427 (.098")	#1444 (.065" x .037")	Rod
20	#1429 (.101")	#1451 (.070" x .047")	Rod & Jet
21	#1427 (.098")	#1445 (.065" x .047")	Rod
22	#1427 (.098")	#1460 (.065" x .052")	Rod
23	#1426 (.095")	#1441 (.062" x .052")	Rod & Jet
24	#1426 (.095")	#1439 (.060" x .052")	Rod & Jet
25	#1426 (.095")	#1438 (.058" x .052")	Rod & Jet
26	#1427 (.098")	#1441 (.062" x .052")	Rod
27	#1427 (.098")	#1443 (.063" x .047")	Rod
28	#1429 (.101")	#1462 (.067" x .049")	Rod & Jet
29	#1430 (.104")	#1452 (.070" x .052")	Rod & Jet

SECONDARY METERING

The factory calibration jet is shown in the center column. For leaner or richer calibration use the jet # indicated in the appropriate column.

3 Stages Lean (12%)	2 Stages Lean (8%)	1 Stage Lean (4%)	SECONDARY Stock Calibration	1 Stage Rich (4%)	2 Stages Rich (8%)	3 Stages Rich (12%)
Jet #1425 (.092")	Jet #1426 (.095")	Jet #1427 (.098")	Jet #1429 (.101")	Jet #1430 (.104")	Jet #1431 (.107")	Jet #1432 (.110")

Main Jet I.D.—All Edelbrock jets have "120-" prefix. The last three digits minus 300 = actual jet size.

Examples: 120-398 = .098" jet (Edelbrock p/n 1427).
120-401 = .101" jet (Edelbrock p/n 1429).

CALIBRATION REFERENCE CHART

PRIMARY METERING #1411

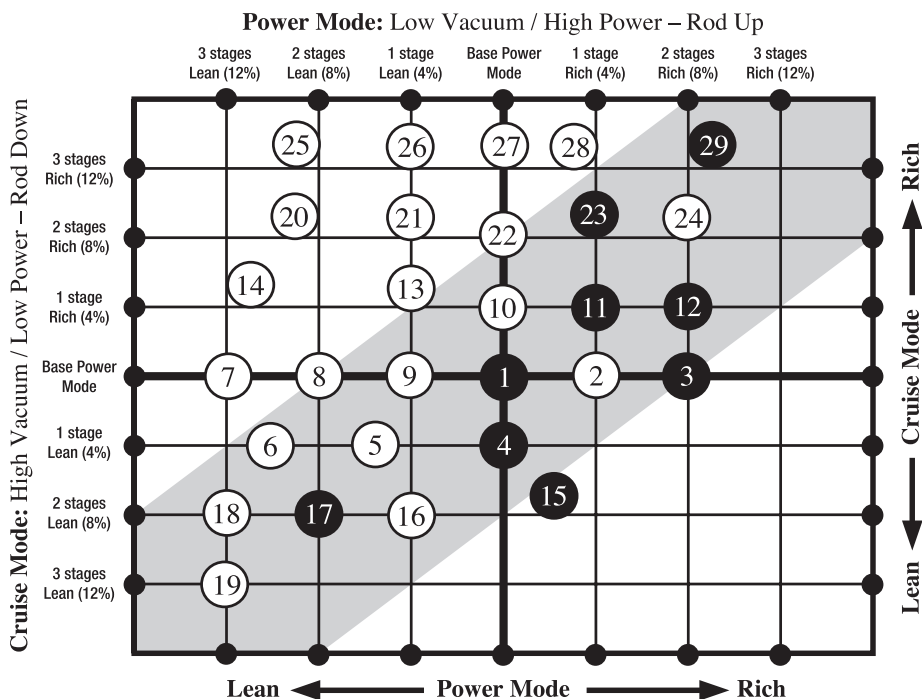

- 1** Stock Calibration
- #** Numbers in black are the steps obtainable using **Calibration Kit #1489** plus the stock jets and metering rods.
- #** Numbers in white are the steps obtainable using jet and rod combinations shown on the following page.

- Step 1 Select the combination of Cruise Mode and Power Mode fuel-metering stages desired for your calibration. Normal calibration changes will be within the gridded diagonal area. That is, Cruise and Power mode changes should be in the same direction (either richer or leaner) and usually by the same amount.
- Step 2 Find the number that is nearest your desired combination. This is your Calibration Reference Number.
- Step 3 Go to the next page. Find the Calibration Reference Number you have just selected in Step 2. Listed will be the Main Jet and Metering Rod required to achieve the desired fuel metering for the Primaries.

ROD/JET REFERENCE CHART

Ref #	Main Jet	Metering Rod	Change from Base
1	#1432 (.110")	#1459 (.075" x .047")	none - stock calibration
2	#1432 (.110")	#1419 (.075" x .042")	Rod
3	#1432 (.110")	#1458 (.075" x .037")	Rod
4	#1431 (.107")	#1454 (.073" x .037")	Rod & Jet
5	#1431 (.107")	#1456 (.073" x .047")	Rod & Jet
6	#1431 (.107")	#1457 (.073" x .052")	Rod & Jet
7	#1430 (.104")	#1445 (.065" x .047")	Rod & Jet
8	#1430 (.104")	#1416 (.065" x .042")	Rod & Jet
9	#1430 (.104")	#1444 (.065" x .037")	Rod & Jet
10	#1432 (.110")	#1456 (.073" x .047")	Rod
11	#1432 (.110")	#1455 (.073" x .042")	Rod
12	#1432 (.110")	#1454 (.073" x .037")	Rod
13	#1431 (.107")	#1447 (.068" x .047")	Rod & Jet
14	#1431 (.107")	#1448 (.068" x .052")	Rod & Jet
15	#1431 (.107")	#1458 (.075" x .037")	Rod & Jet
16	#1430 (.104")	#1449 (.070" x .037")	Rod & Jet
17	#1430 (.104")	#1450 (.070" x .042")	Rod & Jet
18	#1430 (.104")	#1451 (.070" x .047")	Rod & Jet
19	#1430 (.104")	#1453 (.071" x .047")	Rod & Jet
20	#1432 (.110")	#1418 (.070" x .057")	Rod
21	#1432 (.110")	#1452 (.070" x .052")	Rod
22	#1432 (.110")	#1453 (.071" x .047")	Rod
23	#1432 (.110")	#1450 (.070" x .042")	Rod
24	#1432 (.110")	#1449 (.070" x .037")	Rod
25	#1432 (.110")	#1417 (.068" x .057")	Rod
26	#1432 (.110")	#1448 (.068" x .052")	Rod
27	#1432 (.110")	#1447 (.068" x .047")	Rod
28	#1432 (.110")	#1446 (.068" x .042")	Rod
29	#1433 (.113")	#1455 (.073" x .042")	Rod & Jet

SECONDARY METERING

The factory calibration jet is shown in the center column. For leaner or richer calibration use the jet # indicated in the appropriate column.

3 Stages Lean (12%)	2 Stages Lean (8%)	1 Stage Lean (4%)	SECONDARY Stock Calibration	1 Stage Rich (4%)	2 Stages Rich (8%)	3 Stages Rich (12%)
Jet #1427 (.098")	Jet #1429 (.101")	Jet #1430 (.104")	Jet #1431 (.107")	Jet #1432 (.110")	Jet #1433 (.113")	Jet #1434 (.116")

Main Jet I.D.—All Edelbrock jets have "120-" prefix. The last three digits minus 300 = actual jet size.

Examples: 120-398 = .098" jet (Edelbrock p/n 1427).
120-413 = .113" jet (Edelbrock p/n 1433).

CALIBRATION REFERENCE CHART

PRIMARY METERING #1412/#1413

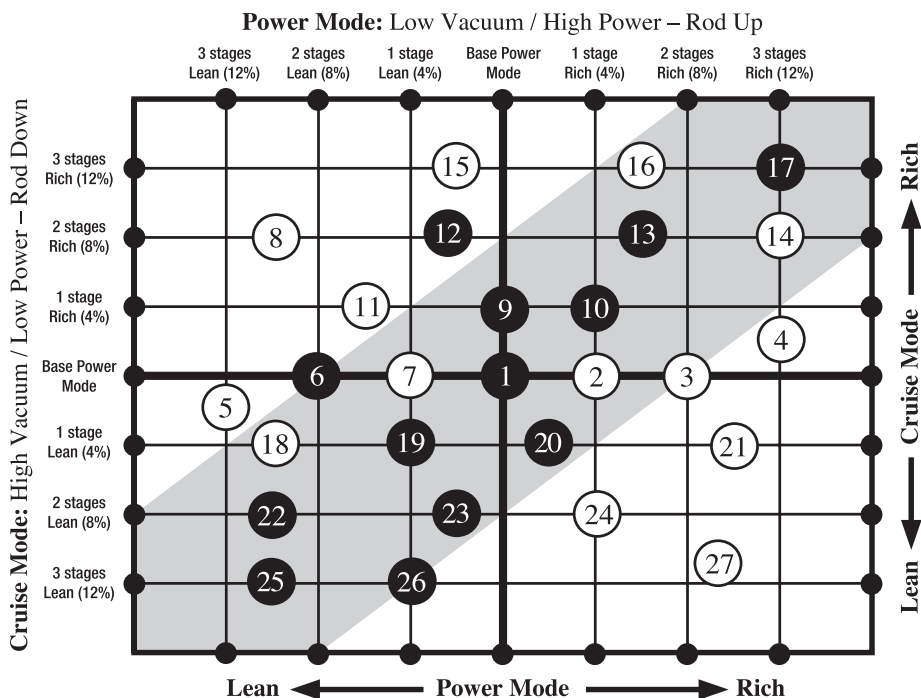

- 1** Stock Calibration
- #** Numbers in black are the steps obtainable using **Calibration Kit #1480** plus the stock jets and metering rods.
- #** Numbers in white are the steps obtainable using jet and rod combinations shown on the following page.

- Step 1 Select the combination of Cruise Mode and Power Mode fuel-metering stages desired for your calibration. Normal calibration changes will be within the gridded diagonal area. That is, Cruise and Power mode changes should be in the same direction (either richer or leaner) and usually by the same amount.
- Step 2 Find the number that is nearest your desired combination. This is your Calibration Reference Number.
- Step 3 Go to the next page. Find the Calibration Reference Number you have just selected in Step 2. Listed will be the Main Jet and Metering Rod required to achieve the desired fuel metering for the Primaries.

ROD/JET REFERENCE CHART

Ref #	Main Jet	Metering Rod	Change from Base
1	#1433 (.113")	#1453 (.071" x .047")	none - stock calibration
2	#1433 (.113")	#1450 (.070" x .042")	Rod
3	#1433 (.113")	#1449 (.070" x .037")	Rod
4	#1434 (.116")	#1454 (.073" x .037")	Rod & Jet
5	#1431 (.107")	#1443 (.063" x .047")	Rod & Jet
6	#1432 (.110")	#1445 (.065" x .047")	Rod & Jet
7	#1433 (.113")	#1452 (.070" x .052")	Rod & Jet
8	#1432 (.110")	#1441 (.062" x .052")	Rod & Jet
9	#1433 (.113")	#1447 (.068" x .047")	Rod
10	#1434 (.116")	#1456 (.073" x .047")	Rod & Jet
11	#1432 (.110")	#1443 (.063" x .047")	Rod & Jet
12	#1433 (.113")	#1445 (.065" x .047")	Rod
13	#1434 (.116")	#1453 (.071" x .047")	Jet
14	#1434 (.116")	#1449 (.070" x .037")	Rod & Jet
15	#1433 (.113")	#1443 (.063" x .047")	Rod
16	#1433 (.113")	#1442 (.063" x .037")	Rod
17	#1434 (.116")	#1444 (.065" x .037")	Rod & Jet
18	#1432 (.110")	#1452 (.070" x .052")	Rod & Jet
19	#1433 (.113")	#1457 (.073" x .052")	Rod
20	#1433 (.113")	#1456 (.073" x .047")	Rod
21	#1433 (.113")	#1454 (.073" x .047")	Rod
22	#1431 (.107")	#1445 (.065" x .047")	Rod & Jet
23	#1431 (.107")	#1444 (.065" x .037")	Rod & Jet
24	#1432 (.110")	#1449 (.070" x .037")	Rod & Jet
25	#1431 (.107")	#1447 (.068" x .047")	Rod & Jet
26	#1432 (.110")	#1456 (.073" x .047")	Rod & Jet
27	#1432 (.110")	#1454 (.073" x .037")	Rod & Jet

SECONDARY METERING

The factory calibration jet is shown in the center column. For leaner or richer calibration use the jet # indicated in the appropriate column.

3 Stages Lean (12%)	2 Stages Lean (8%)	1 Stage Lean (4%)	SECONDARY Stock Calibration	1 Stage Rich (4%)	2 Stages Rich (8%)	3 Stages Rich (12%)
Jet #1425 (.092")	Jet #1426 (.095")	Jet #1427 (.098")	Jet #1429 (.101")	Jet #1430 (.104")	Jet #1431 (.107")	Jet #1432 (.110")

Main Jet I.D.—All Edelbrock jets have "120-" prefix. The last three digits minus 300 = actual jet size.

Examples: 120-398 = .098" jet (Edelbrock p/n 1427).
120-413 = .113" jet (Edelbrock p/n 1433).

CALIBRATION REFERENCE CHART

PRIMARY METERING #1805/#1806

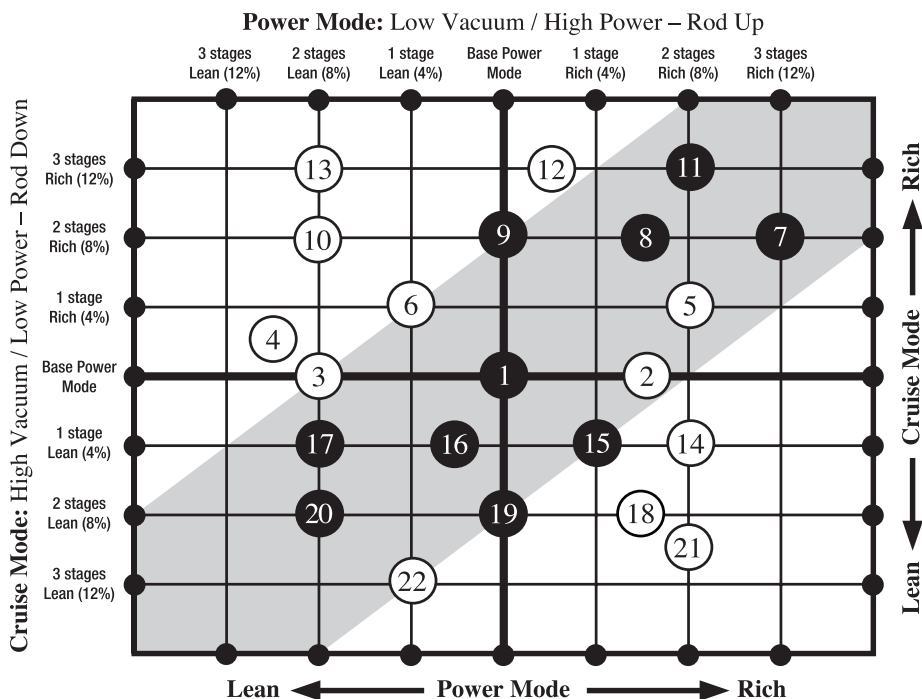

- 1** Stock Calibration
- #** Numbers in black are the steps obtainable using **Calibration Kit #1840** plus the stock jets and metering rods.
- #** Numbers in white are the steps obtainable using jet and rod combinations shown on the following page.

- Step 1 Select the combination of Cruise Mode and Power Mode fuel-metering stages desired for your calibration. Normal calibration changes will be within the gridded diagonal area. That is, Cruise and Power mode changes should be in the same direction (either richer or leaner) and usually by the same amount.
- Step 2 Find the number that is nearest your desired combination. This is your Calibration Reference Number.
- Step 3 Go to the next page. Find the Calibration Reference Number you have just selected in Step 2. Listed will be the Main Jet and Metering Rod required to achieve the desired fuel metering for the Primaries.

ROD/JET REFERENCE CHART

Ref #	Main Jet	Metering Rod	Change from Base
1	#1426 (.095")	#1447 (.068" x .047")	none - stock calibration
2	#1426 (.095")	#1446 (.068" x .042")	Rod
3	#1426 (.095")	#1448 (.068" x .052")	Rod
4	#1425 (.092")	#1443 (.063" x .047")	Rod & Jet
5	#1427 (.098")	#1453 (.071" x .047")	Rod & Jet
6	#1426 (.095")	#1462 (.067" x .049")	Rod
7	#1426 (.095")	#1444 (.065" x .037")	Rod
8	#1426 (.095")	#1416 (.065" x .042")	Rod
9	#1426 (.095")	#1445 (.065" x .047")	Rod
10	#1426 (.095")	#1460 (.065" x .052")	Rod
11	#1427 (.098")	#1447 (.068" x .047")	Jet
12	#1427 (.098")	#1448 (.068" x .052")	Rod & Jet
13	#1427 (.098")	#1417 (.068" x .057")	Rod & Jet
14	#1427 (.098")	#1456 (.073" x .047")	Rod & Jet
15	#1425 (.092")	#1444 (.065" x .037")	Rod & Jet
16	#1425 (.092")	#1416 (.065" x .042")	Rod & Jet
17	#1425 (.092")	#1445 (.065" x .047")	Rod & Jet
18	#1426 (.095")	#1450 (.070" x .042")	Rod
19	#1426 (.095")	#1451 (.070" x .047")	Rod
20	#1426 (.095")	#1452 (.070" x .052")	Rod
21	#1427 (.098")	#1459 (.075" x .047")	Rod & Jet
22	#1427 (.098")	#1442 (.063" x .037")	Rod & Jet

SECONDARY METERING

The factory calibration jet is shown in the center column. For leaner or richer calibration use the jet # indicated in the appropriate column.

3 Stages Lean (12%)	2 Stages Lean (8%)	1 Stage Lean (4%)	SECONDARY Stock Calibration	1 Stage Rich (4%)	2 Stages Rich (8%)	3 Stages Rich (12%)
Jet #1424 (.089")	Jet #1425 (.092")	Jet #1426 (.095")	Jet #1427 (.098")	Jet #1429 (.101")	Jet #1430 (.104")	Jet #1431 (.107")

Main Jet I.D.—All Edelbrock jets have "120-" prefix. The last three digits minus 300 = actual jet size.

Examples: 120-398 = .098" jet (Edelbrock p/n 1427).
120-401 = .101" jet (Edelbrock p/n 1429).

CALIBRATION REFERENCE CHART

PRIMARY METERING #1812/#1813

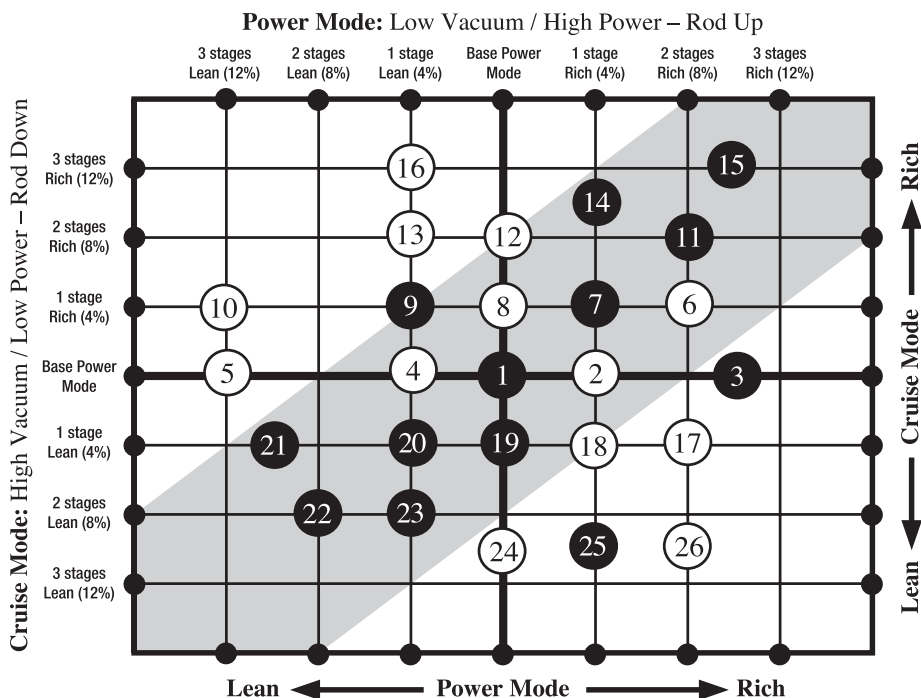

- 1** Stock Calibration
- #** Numbers in black are the steps obtainable using **Calibration Kit #1841** plus the stock jets and metering rods.
- #** Numbers in white are the steps obtainable using jet and rod combinations shown on the following page.

- Step 1 Select the combination of Cruise Mode and Power Mode fuel-metering stages desired for your calibration. Normal calibration changes will be within the gridded diagonal area. That is, Cruise and Power mode changes should be in the same direction (either richer or leaner) and usually by the same amount.
- Step 2 Find the number that is nearest your desired combination. This is your Calibration Reference Number.
- Step 3 Go to the next page. Find the Calibration Reference Number you have just selected in Step 2. Listed will be the Main Jet and Metering Rod required to achieve the desired fuel metering for the Primaries.

ROD/JET REFERENCE CHART

Ref #	Main Jet	Metering Rod	Change from Base
1	#1433 (.113")	#1447 (.068" x .047")	none - stock calibration
2	#1433 (.113")	#1446 (.068" x .042")	Rod
3	#1434 (.116")	#1455 (.073" x .042")	Rod & Jet
4	#1433 (.113")	#1448 (.068" x .052")	Rod
5	#1433 (.113")	#1417 (.068" x .057")	Rod
6	#1433 (.113")	#1444 (.065" x .037")	Rod
7	#1433 (.113")	#1416 (.065" x .042")	Rod
8	#1433 (.113")	#1445 (.065" x .047")	Rod
9	#1434 (.116")	#1418 (.070" x .057")	Rod & Jet
10	#1433 (.113")	#1461 (.065" x .057")	Rod
11	#1433 (.113")	#1442 (.063" x .037")	Rod
12	#1433 (.113")	#1443 (.063" x .047")	Rod
13	#1434 (.116")	#1417 (.068" x .057")	Rod & Jet
14	#1434 (.116")	#1462 (.067" x .049")	Rod & Jet
15	#1434 (.116")	#1416 (.065" x .042")	Rod & Jet
16	#1434 (.116")	#1461 (.065" x .057")	Rod & Jet
17	#1433 (.113")	#1449 (.070" x .037")	Rod
18	#1433 (.113")	#1450 (.070" x .042")	Rod
19	#1433 (.113")	#1451 (.070" x .047")	Rod
20	#1433 (.113")	#1452 (.070" x .052")	Rod
21	#1433 (.113")	#1418 (.070" x .057")	Rod
22	#1432 (.110")	#1462 (.067" x .049")	Rod & Jet
23	#1431 (.107")	#1442 (.063" x .037")	Rod & Jet
24	#1433 (.113")	#1456 (.073" x .047")	Rod
25	#1433 (.113")	#1455 (.073" x .042")	Rod
26	#1433 (.113")	#1454 (.073" x .037")	Rod

SECONDARY METERING

The factory calibration jet is shown in the center column. For leaner or richer calibration use the jet # indicated in the appropriate column.

3 Stages Lean (12%)	2 Stages Lean (8%)	1 Stage Lean (4%)	SECONDARY Stock Calibration	1 Stage Rich (4%)	2 Stages Rich (8%)	3 Stages Rich (12%)
Jet #1425 (.092")	Jet #1426 (.095")	Jet #1427 (.098")	Jet #1429 (.101")	Jet #1430 (.104")	Jet #1431 (.107")	Jet #1432 (.110")

Main Jet I.D.—All Edelbrock jets have "120-" prefix. The last three digits minus 300 = actual jet size.

Examples: 120-398 = .098" jet (Edelbrock p/n 1427).
120-401 = .101" jet (Edelbrock p/n 1429).

CALIBRATION REFERENCE CHART

PRIMARY METERING #1825/#1826

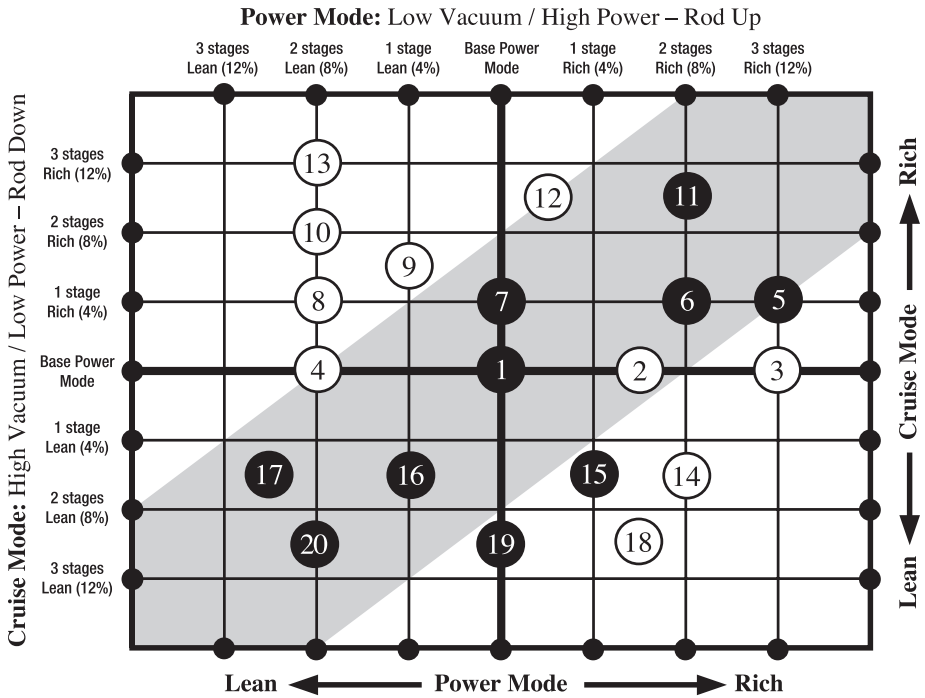

- 1** Stock Calibration
- #** Numbers in black are the steps obtainable using **Calibration Kit #1842** plus the stock jets and metering rods.
- #** Numbers in white are the steps obtainable using jet and rod combinations shown on the following page.

- Step 1 Select the combination of Cruise Mode and Power Mode fuel-metering stages desired for your calibration. Normal calibration changes will be within the gridded diagonal area. That is, Cruise and Power mode changes should be in the same direction (either richer or leaner) and usually by the same amount.
- Step 2 Find the number that is nearest your desired combination. This is your Calibration Reference Number.
- Step 3 Go to the next page. Find the Calibration Reference Number you have just selected in Step 2. Listed will be the Main Jet and Metering Rod required to achieve the desired fuel metering for the Primaries.

ROD/JET REFERENCE CHART

Ref #	Main Jet	Metering Rod	Change from Base
1	#1426 (.095")	#1445 (.065" x .047")	None - stock calibration
2	#1426 (.095")	#1416 (.065" x .042")	Rod
3	#1426 (.095")	#1444 (.065" x .037")	Rod
4	#1426 (.095")	#1460 (.065" x .052")	Rod
5	#1426 (.095")	#1442 (.063" x .037")	Rod
6	#1427 (.098")	#1447 (.068" x .047")	Jet & Rod
7	#1426 (.095")	#1443 (.063" x .047")	Rod
8	#1427 (.098")	#1417 (.068" x .057")	Jet & Rod
9	#1427 (.098")	#1463 (.067" x .055")	Jet & Rod
10	#1426 (.095")	#1441 (.062" x .052")	Rod
11	#1427 (.098")	#1445 (.065" x .047")	Jet
12	#1429 (.101")	#1418 (.070" x .057")	Jet & Rod
13	#1426 (.095")	#1439 (.060" x .052")	Rod
14	#1427 (.098")	#1453 (.071" x .047")	Jet & Rod
15	#1425 (.092")	#1442 (.063" x .037")	Jet & Rod
16	#1426 (.095")	#1462 (.067" x .049")	Rod
17	#1425 (.092")	#1443 (.063" x .047")	Jet & Rod
18	#1426 (.095")	#1446 (.068" x .042")	Rod
19	#1426 (.095")	#1447 (.068" x .047")	Rod
20	#1426 (.095")	#1448 (.068" x .052")	Rod

SECONDARY METERING

The factory calibration jet is shown in the center column. For leaner or richer calibration use the jet # indicated in the appropriate column.

3 Stages Lean (12%)	2 Stages Lean (8%)	1 Stage Lean (4%)	SECONDARY Stock Calibration	1 Stage Rich (4%)	2 Stages Rich (8%)	3 Stages Rich (12%)
Jet #1424 (.089")	Jet #1425 (.092")	Jet #1426 (.095")	Jet #1427 (.098")	Jet #1429 (.101")	Jet #1430 (.104")	Jet #1431 (.107")

Main Jet I.D.—All Edelbrock jets have "120-" prefix. The last three digits minus 300 = actual jet size.

Examples: 120-398 = .098" jet (Edelbrock p/n 1427).
120-402 = .101" jet (Edelbrock p/n 1429).

CALIBRATION REFERENCE CHART

PRIMARY METERING #1901/#1902/#1903/#1904

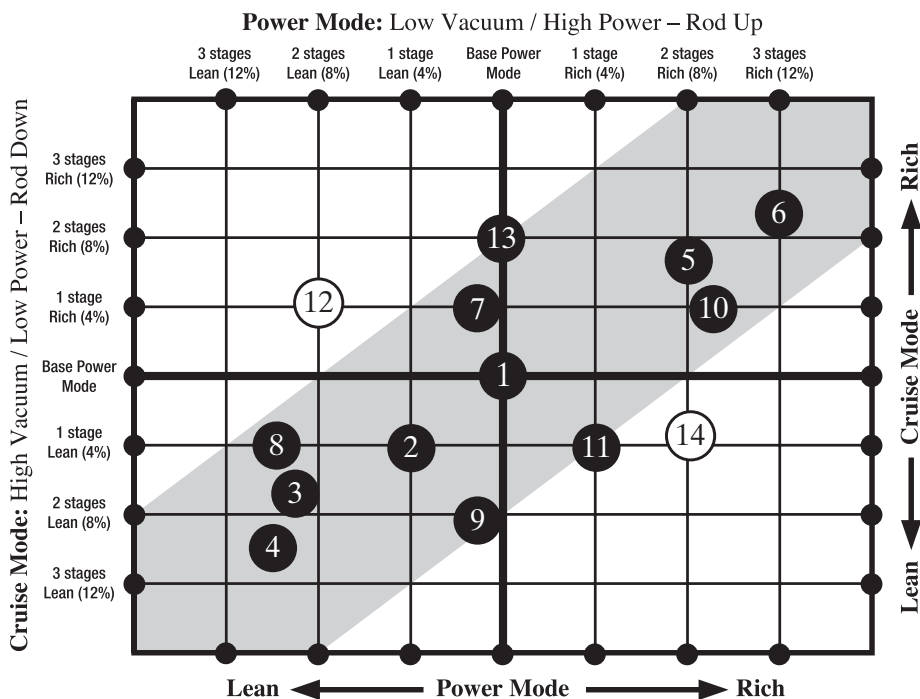

- 1** Stock Calibration
- #** Numbers in black are the steps obtainable using **Calibration Kit #1940** plus the stock jets and metering rods.
- #** Numbers in white are the steps obtainable using jet and rod combinations shown on the following page.

- Step 1 Select the combination of Cruise Mode and Power Mode fuel-metering stages desired for your calibration. Normal calibration changes will be within the gridded diagonal area. That is, Cruise and Power mode changes should be in the same direction (either richer or leaner) and usually by the same amount.
- Step 2 Find the number that is nearest your desired combination. This is your Calibration Reference Number.
- Step 3 Go to the next page. Find the Calibration Reference Number you have just selected in Step 2. Listed will be the Main Jet and Metering Rod required to achieve the desired fuel metering for the Primaries.

ROD/JET REFERENCE CHART

Ref #	Main Jet	Metering Rod	Change from Base
1	#1426 (.095")	#1452 (.070" x .052")	none - stock calibration
2	#1425 (.092")	#1462 (.067" x .049")	Rod & Jet
3	#1425 (.092")	#1448 (.068" x .052")	Rod & Jet
4	#1424 (.089")	#1445 (.065" x .047")	Rod & Jet
5	#1426 (.095")	#1447 (.068" x .047")	Rod
6	#1425 (.092")	#1442 (.063" x .037")	Rod & Jet
7	#1425 (.092")	#1445 (.065" x .047")	Rod & Jet
8	#1424 (.089")	#1443 (.063" x .047")	Rod & Jet
9	#1425 (.092")	#1447 (.068" x .047")	Rod & Jet
10	#1427 (.098")	#1457 (.073" x .052")	Rod & Jet
11	#1424 (.089")	#1442 (.063" x .037")	Rod & Jet
12	#1425 (.092")	#1460 (.065" x .052")	Rod & Jet
13	#1426 (.095")	#1448 (.068" x .052")	Rod
14	#1426 (.095")	#1453 (.071" x .047")	Rod

#1901/#1902 SECONDARY METERING

The factory calibration jet is shown in the center column. For leaner or richer calibration use the jet # indicated in the appropriate column.

2 Stages Lean (12%)	1 Stage Lean (6%)	SECONDARY Stock Calibration	1 Stage Rich (6%)	2 Stages Rich (12%)
Jet #1424 (.089")	Jet #1425 (.092")	Jet #1426 (.095")	Jet #1427 (.098")	Jet #1428 (.100")

#1903/#1904 SECONDARY METERING

The factory calibration jet is shown in the first column. For richer calibration use the jet # indicated in the appropriate column to the right.

SECONDARY Stock Calibration	1 Stage Rich (8%)	2 Stages Rich (16%)	3 Stages Rich (25%)	4 Stages Rich (34%)
Jet #1420 (.077")	Jet #1421 (.080")	Jet #1422 (.083")	Jet #1423 (.086")	Jet #1424 (.092")

Main Jet I.D.—All Edelbrock jets have "120-" prefix. The last three digits minus 300 = actual jet size.

Examples: 120-398 = .098" jet (Edelbrock p/n 1427).
120-413 = .113" jet (Edelbrock p/n 1433).

CALIBRATION REFERENCE CHART

PRIMARY METERING #1905/#1906

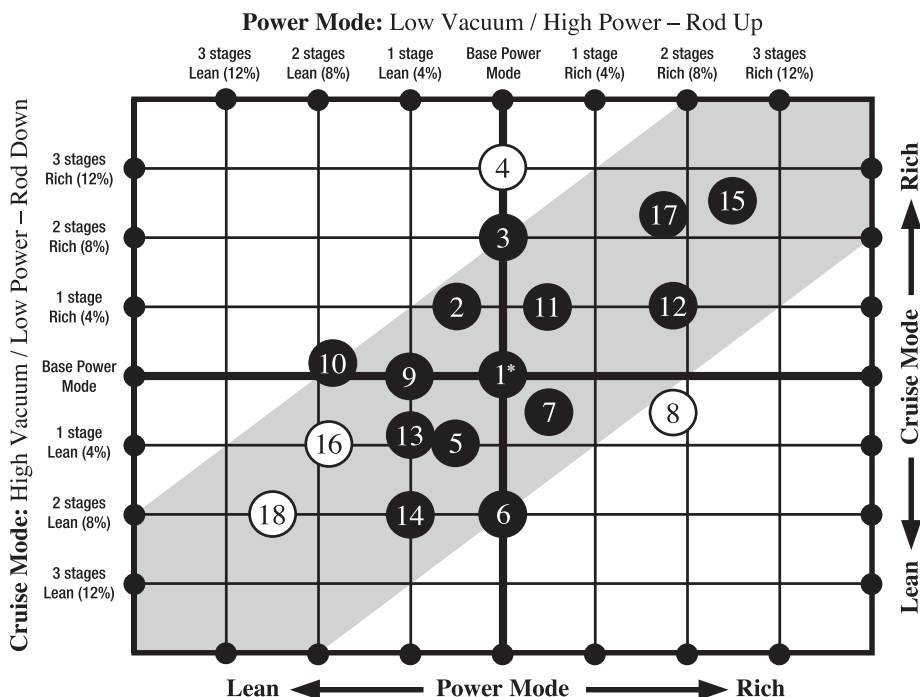

- 1** Stock Calibration
- #** Numbers in black are the steps obtainable using **Calibration Kit #1948** plus the stock jets and metering rods.
- #** Numbers in white are the steps obtainable using jet and rod combinations shown on the following page.

- Step 1 Select the combination of Cruise Mode and Power Mode fuel-metering stages desired for your calibration. Normal calibration changes will be within the gridded diagonal area. That is, Cruise and Power mode changes should be in the same direction (either richer or leaner) and usually by the same amount.
- Step 2 Find the number that is nearest your desired combination. This is your Calibration Reference Number.
- Step 3 Go to the next page. Find the Calibration Reference Number you have just selected in Step 2. Listed will be the Main Jet and Metering Rod required to achieve the desired fuel metering for the Primaries.

ROD/JET REFERENCE CHART

Ref #	Main Jet	Metering Rod	Change from Base
1	#1429 (.101")	#1449 (.070" x .037")	None - stock calibration
2	#1428 (.100")	#1955 (.067" x .037")	Jet & Rod
3	#1429 (.101")	#1955 (.067" x .037")	Rod
4	#1429 (.101")	#1444 (.065" x .037")	Rod
5	#1428 (.100")	#1449 (.070" x .037")	Jet
6	#1429 (.101")	#1454 (.073" x .037")	Rod
7	#1430 (.104")	#1419 (.075" x .042")	Jet & Rod
8	#1430 (.104")	#1458 (.075" x .037")	Jet & Rod
9	#1429 (.101")	#1450 (.070" x .042")	Rod
10	#1428 (.100")	#1446 (.068" x .042")	Jet & Rod
11	#1430 (.104")	#1455 (.073" x .042")	Jet & Rod
12	#1430 (.104")	#1454 (.073" x .037")	Jet & Rod
13	#1429 (.101")	#1956 (.071" x .042")	Rod
14	#1429 (.101")	#1455 (.073" x .042")	Rod
15	#1431 (.107")	#1419 (.075" x .042")	Jet & Rod
16	#1427 (.098")	#1955 (.067" x .037")	Jet & Rod
17	#1430 (.104")	#1449 (.070" x .037")	Jet
18	#1429 (.101")	#1456 (.073" x .047")	Rod

SECONDARY METERING

The factory calibration jet is shown in the center column. For leaner or richer calibration use the jet # indicated in the appropriate column.

2 Stages Lean (12%)	1 Stage Lean (6%)	SECONDARY Stock Calibration	1 Stage Rich (4%)	2 Stages Rich (6%)	3 Stages Rich (13%)
Jet #1425 (.092")	Jet #1426 (.095")	Jet #1427 (.098")	Jet #1428 (.100")	Jet #1429 (.101")	Jet #1430 (.104")

Main Jet I.D.—All Edelbrock jets have "120-" prefix. The last three digits minus 300 = actual jet size.

Examples: 120-398 = .098" jet (Edelbrock p/n 1427).
120-413 = .113" jet (Edelbrock p/n 1433).

CALIBRATION REFERENCE CHART

PRIMARY METERING #1912/#1913

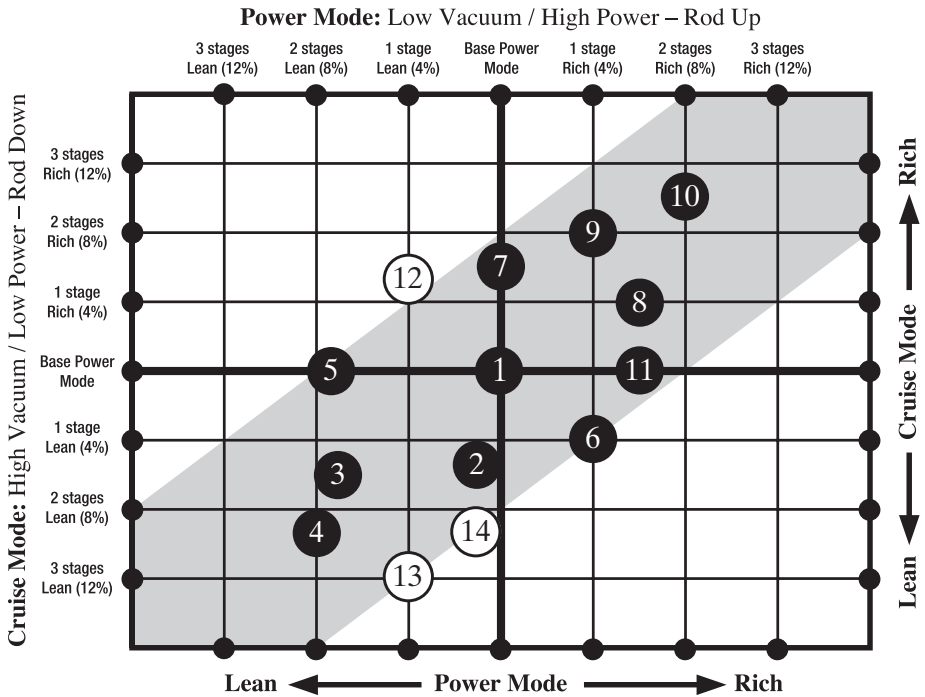

- 1 Stock Calibration
- # Numbers in black are the steps obtainable using **Calibration Kit #1949** plus the stock jets and metering rods.
- # Numbers in white are the steps obtainable using jet and rod combinations shown on the following page.

- Step 1 Select the combination of Cruise Mode and Power Mode fuel-metering stages desired for your calibration. Normal calibration changes will be within the gridded diagonal area. That is, Cruise and Power mode changes should be in the same direction (either richer or leaner) and usually by the same amount.
- Step 2 Find the number that is nearest your desired combination. This is your Calibration Reference Number.
- Step 3 Go to the next page. Find the Calibration Reference Number you have just selected in Step 2. Listed will be the Main Jet and Metering Rod required to achieve the desired fuel metering for the Primaries.

ROD/JET REFERENCE CHART

Ref #	Main Jet	Metering Rod	Change from Base
1	#1430 (.104")	#1460 (.065" x .052")	None - stock calibration
2	#1429 (.101")	#1443 (.063" x .047")	Jet & Rod
3	#1430 (.104")	#1436 (.068" x .057")	Rod
4	#1429 (.101")	#1460 (.065" x .052")	Jet
5	#1430 (.104")	#1461 (.065" x .057")	Rod
6	#1430 (.104")	#1462 (.067" x .049")	Rod
7	#1430 (.104")	#1441 (.062" x .052")	Rod
8	#1430 (.104")	#1443 (.063" x .047")	Rod
9	#1431 (.107")	#1448 (.068" x .052")	Jet & Rod
10	#1431 (.107")	#1460 (.065" x .052")	Jet & Rod
11	#1430 (.104")	#1445 (.065" x .047")	Rod
12	#1429 (.101")	#1437 (.057" x .049")	Jet & Rod
13	#1428 (.100")	#1445 (.065" x .047")	Jet & Rod
14	#1429 (.101")	#1445 (.065" x .047")	Jet & Rod

SECONDARY METERING

The factory calibration jet is shown in the center column. For leaner or richer calibration use the jet # indicated in the appropriate column.

3 Stages Lean (12%)	2 Stages Lean (8%)	1 Stage Lean (6%)	SECONDARY Stock Calibration	1 Stage Rich (6%)	2 Stages Rich (8%)	3 Stages Rich (12%)
Jet #1427 (.098")	Jet #1428 (.100")	Jet #1429 (.101")	Jet #1430 (.104")	Jet #1431 (.107")	N/A	Jet #1432 (.110")

Main Jet I.D.—All Edelbrock jets have "120-" prefix. The last three digits minus 300 = actual jet size.

Examples: 120-398 = .098" jet (Edelbrock p/n 1427).
 120-413 = .113" jet (Edelbrock p/n 1433).

TUNING ACCESSORIES



CARBURETOR CALIBRATION KITS

All calibration kits include an assortment of metering rods and jets, one pair of metering rod retaining springs and a complete assortment of step-up springs (except Calibration Kit #1485 which is designed for a specific application).

***FOR USE ON PRE-POLLUTION CONTROLLED VEHICLES (PPCV):** All products with this icon are legal for use on pre-pollution controlled vehicles. They can be used on all vehicles that were manufactured before emissions control regulations were imposed. These vehicles are considered "uncontrolled vehicles." **Uncontrolled vehicles are defined as...** 1965 and older U.S. manufactured California Certified vehicles, 1967 and older U.S. manufactured Federally Certified vehicles, 1967 and older Foreign manufactured vehicles

PERFORMER SERIES CARBURETORS CALIBRATION KITS

Part No.	Application	Metering Rods (Pair)	Emissions Code	Metering Jets (Pair)
#1486	#1403, #1404, #1801, #1802, #1803 & #1804	.057" x .049", .062" x .052", .063" x .047", .067" x .055", .068" x .052"	*	.083", .089", .092", .098"
#1479	#1405	.068" x .042", .068" x .052", .070" x .052", .073" x .047", .073" x .052", .075" x .047"	*	.089", .092", .098", .101", .104"
#1487	#1406	.070" x .037", .073" x .042", .073" x .047"	*	.095", .098", .101"
#1485	#1409 on 4.3L 90° V6 with Performer Manifolds #2111 & #2114	.068" x .057"	*	.089" (Includes 2 pairs, 4 total jets)
#1488	#1409	.063" x .047", .065" x .052", .070" x .047", .070" x .052", .073" x .047"	*	.092", .095", .098", .101", .104"
#1480	#1407, #1410, #1412 & #1413	.065" x .037", .065" x .047", .068" x .047", .073" x .047", .073" x .052"	*	.101", .104", .107", .110", .113", .116"
#1489	#1411	.070" x .042", .073" x .037", .073" x .042", .075" x .037"	*	.104", .107", .110", .113"

THUNDER SERIES AVS CARBURETORS CALIBRATION KITS

Part No.	Application	Metering Rods (Pair)	Emissions Code	Metering Jets (Pair)
#1840	#1805 & #1806	.065" x .037", .065" x .042", .065" x .047", .070" x .047", .070" x .052"	*	.092", .095", .098", .101", .104"
#1841	#1812 & #1813	.063" x .037", .065" x .042", .067" x .049", .070" x .047", .070" x .052", .070" x .057", .073" x .042"	*	.095", .098", .104", .107", .110", .116"
#1842	#1825 & #1826	.063" x .037", .063" x .047", .067" x .049", .068" x .047", .068" x .052"	*	.092", .095", .098", .101", .104"

AVS2 CARBURETORS CALIBRATION KITS

Part No.	Application	Metering Rods (Pair)	Emissions Code	Metering Jets (Pair)
#1940	#1901, #1902, #1903 & #1904	.063" x .037", .063" x .047", .065" x .047", .067" x .049", .068" x .047", .068" x .052", .073" x .052"	*	.080", .083", .086", .089", .092", .098", .100"
#1948	#1905 & #1906	.067" x .037", .068" x .042", .070" x .042", .071" x .042", .073" x .037", .073" x .042", .075" x .042"	*	.092", .095", .100", .104", .107"
#1949	#1912 & #1913	.062" x .052", .063" x .047", .065" x .047", .065" x .057", .067" x .049", .068" x .052"	*	.100", .101", .107", .110"

TUNING ACCESSORIES



METERING JETS *

These metering jets are designed for use with Edelbrock Performer Series, Thunder Series AVS and AVS2 Series carburetors only. Do not use with other brands. **Sold in pairs.**

.077".....	#1420
.080".....	#1421
.083".....	#1422
.086".....	#1423
.089".....	#1424
.092".....	#1425

.095".....	#1426
.098".....	#1427
.100".....	#1428
.101".....	#1429
.104".....	#1430
.107".....	#1431

.110".....	#1432
.113".....	#1433
.116".....	#1434
.119".....	#1435

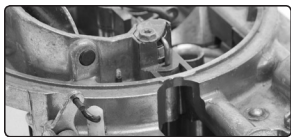

METERING RODS *

These metering rods are designed for use with Edelbrock Performer Series, Thunder Series AVS and AVS2 Series carburetors only. Do not use with other brands. **Sold in pairs.**

Cruise/Power

.057" x .049".....	#1437
.062" x .052".....	#1441
.063" x .037".....	#1442
.063" x .047".....	#1443
.065" x .037".....	#1444
.065" x .042".....	#1416
.065" x .047".....	#1445
.065" x .052".....	#1460
.065" x .057".....	#1461
.067" x .037".....	#1955

Cruise/Power

.067" x .049".....	#1462
.067" x .055".....	#1463
.068" x .042".....	#1446
.068" x .047".....	#1447
.068" x .052".....	#1448
.068" x .057".....	#1436
.070" x .037".....	#1449
.070" x .042".....	#1450
.070" x .047".....	#1451
.070" x .052".....	#1452

Cruise/Power

.070" x .057".....	#1418
.071" x .042".....	#1956
.071" x .047".....	#1453
.073" x .037".....	#1454
.073" x .042".....	#1455
.073" x .047".....	#1456
.073" x .052".....	#1457
.075" x .037".....	#1458
.075" x .042".....	#1419
.075" x .047".....	#1459



#2691

CARBURETOR ADAPTERS

Carb adapters allow proper installation of carb-to-manifold. Number in parenthesis is thickness of adapter.

4-bbl. Thermo-Quad Adapter (.750") Mounts 4-bbl. Carter Thermo-Quad carbs to square-bore, single-plane manifolds.....#2691*

4-bbl. Quadrajet Adapter (.750") Mounts 4-bbl. Rochester Quadrajet carbs to square-bore, single-plane manifolds.....#2692*

Standard-Flange Sideways Adapters (pair, .550") Mounts standard-flange Holley carbs sideways on Tunnel Rams.....#2694*

Four-Hole, Square-Bore to Spread-Bore Adapter (.850") Mounts Edelbrock square-bore carbs to stock Quadrajet & Thermo-Quad manifolds.....#2696*

Standard-Flange Adapter (2.00") Adapts 4500 Series manifold flange to 4150 Series standard-flange carb.....#8716*

Competition Q-Jet Adapter (.750") Re-locates Q-Jet 5/16" to the rear for improved fuel distribution on square-bore single plane manifolds.....#2693*

*FOR USE ON PRE-POLLUTION CONTROLLED VEHICLES (PPCV): All products with this icon are legal for use on pre-pollution controlled vehicles. They can be used on all vehicles that were manufactured before emissions control regulations were imposed. These vehicles are considered "uncontrolled vehicles." **Uncontrolled vehicles are defined as...** 1965 and older U.S. manufactured California Certified vehicles, 1967 and older U.S. manufactured Federally Certified vehicles, 1967 and older Foreign manufactured vehicles

INSTALLATION COMPONENTS

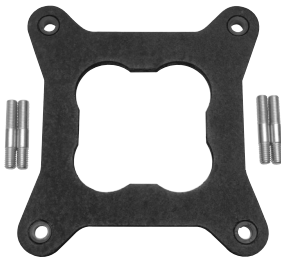

#9265

HEAT INSULATOR GASKETS

Designed to help prevent fuel percolation in Performer Series, Thunder Series AVS and AVS2 carburetors exposed to extreme under hood temperatures. Use #9265 with open plenum manifolds such as Torker II and Victors. #9266 features a divided center which is designed to seal the carburetor to dual-plane manifolds including Performer, Performer RPM and most RPM Air-Gap manifolds. All gaskets come with extended carb studs.

Square-Bore Heat Insulator Gasket (0.320" thick).....#9265
Divided Square-Bore Heat Insulator Gasket (0.320" thick)#9266



#9266

Q-JET REPLACEMENT KIT

This complete kit includes everything you need to add an Edelbrock square-bore (Performer, Thunder Series, AVS2) carburetor to a stock Q-Jet or Thermo-Quad intake manifold with a spread-bore flange.

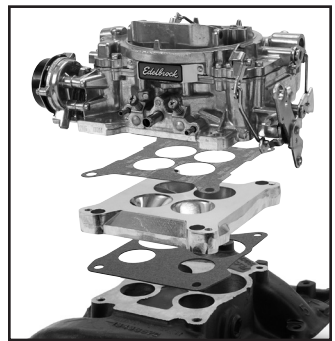

Kit includes: Spread bore to square bore adapter plate, 24" fuel hose, fuel filter, 3/8" adapter fitting, carb studs, gaskets and all of the necessary hardware for an easy installation.

QuadraJet Adapter and Fuel Line Kit#2697



#2697

CARB STUDS AND FITTINGS



#8008

	Zinc Black
Carb Stud, Nut and Washer Kit (5/16"-18 x 1-1/4").....	#8006.....N/A
Carb Stud, Nut and Washer Kit (5/16"-18 x 1-1/2").....	#8008.....#8079
Carb Stud, Nut and Washer Kit (5/16"-18 x 1-3/4").....	#8024.....N/A
Carb Stud, Nut and Washer Kit (5/16"-18 x 2").....	N/A.....#8060
Vacuum Fitting (low profile) for Holley Double-Pumper when used with 3/8" male x 1/8" female NPT fitting with #2101, #5001, #7101, #7501 (.650").....	#8096
Vacuum Caps (1/8", 3/16", 1/4", 5/16" and 3/8", Set of 20).....	#4804
Single Barb Carb Fitting (1/4"-18 NPT x 3/8" Barb).....	#8080
#6 AN Fitting for Edelbrock Square-Bore & Carter AFB Carbs (5/8"-20).....	#8087
Banjo Fitting for Edelbrock Square-Bore & Carter AFB Carbs (5/8"-20).....	#8089
Inverted Flare Fuel Line Fitting for Edelbrock Square-Bore & AFB Carbs (3/8").....	#8090

INSTALLATION COMPONENTS

CARBURETOR MAINTENANCE KITS

Float Kit (includes 2 floats, 2 pins and a float setting gauge).....#1469

Accelerator Pump Assembly for #1400, #1403, #1404, #1405, #1406, #1801, #1802, #1803, #1804, #1805, #1806, #1825, #1826, #1901, #1902, #1903, #1904, #1905, #1906....#1470

Accelerator Pump Assembly for #1407, and #1411#1467*

Accelerator Pump Assembly for #1412, #1413, #1812, & #1813.....#1468*

Marine Accelerator Pump (includes seal, spring and cup assembly for #1409/#1410)#1471*

Performer Series Linkage Kit (includes 1 ea. of AVS2 7 links and 6 retaining clips).....#1473

Choke Cable Bracket & Clamp Assembly (Performer Series & Thunder Series AVS, AVS2 carbs).....#1494

Choke Cap Kit (includes choke cap and gasket, 3 screws and 3 locking tabs).....#1474

AVS Carb Linkage Kit (includes 1 ea. of 7 links with black finish and 6 retaining clips).....#1873

Carburetor Rebuild Kit (includes parts and gaskets to rebuild all Edelbrock square-bore carbs).....#1477

Replacement Fuel Inlet Fitting (5/8"-20, 3/8" nipple, gold iridited)....#1497

Replacement Needles and Seats (.0935" diameter, pair).....#1498

AIR/FUEL RATIO MONITOR

This Air/Fuel Monitor displays the actual air/fuel mixture in ratios from approximately 12 to 15:1. Use it to guide carburetor adjustment and jetting or to improve ignition spark advance curves. Not for use with leaded fuels or alcohol. Kit includes oxygen sensor, bung, harness, display unit and installation instructions.

Air/Fuel Ratio Monitor.....#6593

Replacement Oxygen Sensor with 18mm Bung#3591

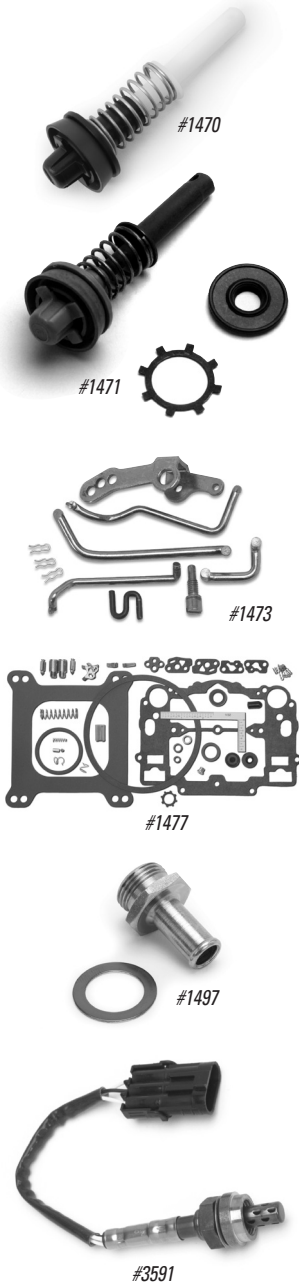

***FOR USE ON PRE-POLLUTION CONTROLLED VEHICLES (PPCV):** All products with this icon are legal for use on pre-pollution controlled vehicles. They can be used on all vehicles that were manufactured before emissions control regulations were imposed. These vehicles are considered "uncontrolled vehicles." **Uncontrolled vehicles are defined as...** 1965 and older U.S. manufactured California Certified vehicles, 1967 and older U.S. manufactured Federally Certified vehicles, 1967 and older Foreign manufactured vehicles

INSTALLATION COMPONENTS

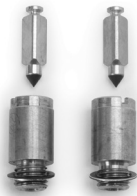

#1466

TUNING ACCESSORIES FOR PERFORMER SERIES, THUNDER SERIES AVS AND AVS2 SERIES CARBS

Step-Up Spring Assortment (includes 3" Hg (blue), 4" Hg (yellow), 5" Hg (orange), 7" Hg (pink) and 8" Hg (plain) Springs. – 5 pair).....#1464*

Accelerator Pump Nozzles (includes .024, .033, .043 nozzles and gaskets)#1475*

Off-Road Needles and Seats (includes a pair of spring loaded needles and .0935" seats)#1465

High Flow Needles and Seats (includes a pair of needles and .110" seats)#1466*

EGR Adapter#1476

Electric Choke Kit (includes all parts necessary to convert #1404, #1405, #1407 and #1412 Edelbrock Performer Series carbs to electric choke. **Not for Thunder Series AVS or AVS2 carbs**)....#1478

Chevy/GMC Cruise Control Kit (required for OEM cruise control hook-up).....#1484

Idle Mixture Screw Set (includes a pair of idle mixture screws and springs for all Edelbrock square-bore carburetors)#1496

Banjo Fitting (3/8" inlet, 5/8"-20)#8089

-6 AN Fitting (5/8" -20)#8087

Inverted Flare Fitting (for 3/8" tubing, 5/8"-20)#8090



#1478



#8059



#1481

THROTTLE LEVER ADAPTERS FOR CHRYSLER AND FORD

Throttle Lever Adapter #1481 fits 1966 and later Chrysler's. #1483 is for Ford automatic transmission equipped vehicles with cable operated throttle (except A.O.D.). Both accept cruise control. Use with appropriate throttle cable plate when necessary. Available in gold iridited finish to match Edelbrock Performer Series Carbs or black to match Edelbrock Thunder Series AVS Carbs.



#1844

Gold Black

Chrysler Throttle Lever Adapter (1966 and later).....#1481* ...#1843*

Ford Throttle Lever Adapter (1968 and later)#1483* ...#1844*

***FOR USE ON PRE-POLLUTION CONTROLLED VEHICLES (PPCV):** All products with this icon are legal for use on pre-pollution controlled vehicles. They can be used on all vehicles that were manufactured before emissions control regulations were imposed. These vehicles are considered "uncontrolled vehicles."

Uncontrolled vehicles are defined as... 1965 and older U.S. manufactured California Certified vehicles, 1967 and older U.S. manufactured Federally Certified vehicles, 1967 and older Foreign manufactured vehicles

INSTALLATION COMPONENTS



#8003



#8022



#8016



#8026



#8030



#8032

THROTTLE BRACKETS AND HARDWARE

Automatic Trans. Rod Extension Kit for 1/4" Rod for Chrysler... #8003

Automatic Trans. Rod Extension Kit for 5/16" Rod for Chrysler... #8004

Automatic Trans. Rod Extension Kit for Ford #8011

Automatic Trans. Kickdown Stud for 1982 & later TH350, 200R4, 700R4 #8018

Trans. Kick-Down Linkage Adapter Kit for 1977 Chrysler Vans... #8022

Throttle & Automatic Trans. Shoulder Stud Kit for Early Chrysler..... #8007

Throttle Cable Adapter for Chevy (1977 & later) #8009

Universal Throttle Rod Extension Kit (7-1/2" long)..... #8010

Throttle or Automatic Trans. Cable Extension Kit for Chevy #8012

Throttle Bracket for #2156 & #5056 for Pontiac (1972-76, supplied w/manifolds) #8014

Throttle Bracket for Pontiac (1968-71) #8015

Throttle Bracket for Performer 454 T.B.I. #3764 (1987-90)..... #8019

Universal Throttle Return Kit #8005

GM Transmission Cable Adapter (For use with 2004R, 700R4, 4L60 transmissions)..... #8026

AMC Throttle Cable Adapter (1979 and later)..... #8034

LS1 Throttle and Trans Bracket (for carbureted applications) #8029

Throttle, Cruise Control & Trans. Kick-Down Mounting Bracket for Small-Block Chevy (1978 & earlier with TH350, 2004R, or 700R4 trans. Chrome Plated)..... #8030

Throttle, Cruise Control & Trans. Kick-Down Mounting Bracket Cad. for Small-Block Chevy (1978 & earlier with TH350, 2004R, or 700R4 trans. Gold Plated)..... #8036

Idle Compensator Kit Maintains correct idle speed when air conditioner is on. (includes 12-volt solenoid and mounting bracket for all Edelbrock square-bore carburetors).... #8059

Throttle Rod Shoulder Stud for Chevy #9141

Universal Throttle Bracket for Small-Block and Big-Block Chevy's..... #8031

Universal Throttle Bracket for Small-Block Chevy Vortec/E-Tec (black powder coated and adjustable to fit both EFI and standard intake manifolds. Part #8032 is uniquely designed for maximum adjustability on any small-block Chevy Vortec style manifold. Will also work with Edelbrock Performer #2114) #8032

INLET KITS

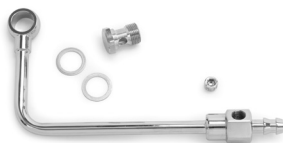

#8126



#8131



#8134

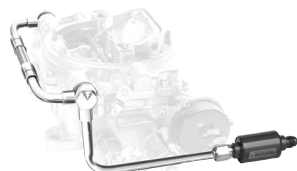

#8133



#624010

FUEL INLET AND FILTER KITS

SINGLE FEED FOR EDELBROCK PERFORMER SERIES, THUNDER SERIES AVS AND AVS2 CARBURETORS

These fuel inlets for Edelbrock carburetors provide a clean and custom plumbing solution. The drop-down design routes the fuel line on the right-hand (passenger side) of the carb below the linkage and choke housing. #8126 and #81263 includes a barbed end for a push-on 3/8" rubber fuel line. #8131, #8134 and #81343 includes an aluminum fuel filter with a 40 micron filter element and -6 AN male inlet will accept an Edelbrock fuel line kit for a complete fuel pump to carburetor plumbing solution. They are manufactured of plated steel and include a 5/8" -20 threaded banjo bolt with gaskets. Available in chrome or black finish.

- Chrome Steel Fuel Line without Fuel Filter and 3/8" Barbed End Inlet**#8126
- Black Steel Fuel Line without Fuel Filter and 3/8" Barbed End Inlet**#81263
- Chrome Steel Fuel Line with Polished Aluminum Filter** (replacement filter only #8129).....#8131
- Chrome Steel Fuel Line with Blue Anodized Aluminum Filter** (replacement filter only #8130).....#8134
- Black Steel Fuel Line with Black Anodized Aluminum Filter** (replacement filter only #650133).....#81343
- 6 AN Female to Barb** (when using push-on fuel line with #8131 and #8134)#624010

DUAL FEED FOR EDELBROCK THUNDER SERIES AVS AND AVS2 SERIES CARBURETORS

These dual feed fuel inlets are designed specifically for Edelbrock Thunder Series AVS carburetors. The drop-down design routes the fuel line on the right-hand (passenger side) of the carburetor below the linkage and choke housing. Options include a barbed end for a push-on 3/8" fuel line or -6 AN aluminum fuel filter with a 40 micron filter element. Match with Edelbrock fuel line kit for a complete fuel pump to carburetor plumbing solution. They are manufactured of chrome plated steel and include a 5/8" -20 threaded banjo bolt with gaskets.

- Chrome Steel Fuel Line with Polished Aluminum Filter** (replacement filter only #8129).....#8128
- Chrome Steel Fuel Line with No Fuel Filter and 3/8" Barbed End Inlet**#8132
- Chrome Steel Fuel Line with Blue Anodized Aluminum Filter** (replacement filter only #8130).....#8133
- 6 AN Female to Barb** (when using push-on fuel line with #8128 and #8133)#624010

FUEL FILTERS AND HOSE KITS



#624010



#8129



#650133



#8130

HIGH FLOW FUEL FILTERS

Designed for high volume fuel systems these high-quality fuel filters are manufactured of billet aluminum and offer 40 micron filtration. These filters are 3" long by 1-1/4" in diameter and include a 40 micron disc element with a -6 AN male inlet/outlet. Match with Edelbrock pump-to-carb fuel line kits for a complete plumbing solution.

- Polished Aluminum Filter**#8129
- Blue Anodized Aluminum Filter**.....#8130
- Black Anodized Aluminum Filter**#650133
- Replacement Filter Element**.....#8137
- 6 AN Female to Barb**
(when using push-on fuel line with -6 fuel filter)#624010



#8135

UNIVERSAL FUEL HOSE & FILTER KIT

Designed for quick installation when retaining part of the stock steel fuel line, simply cut the stock line and install the compression fitting. Use supplied neoprene hose, clamp and special fuel filter and connect to carb. Will work with either 5/16" or 3/8" lines. Kit includes fuel filter, special fittings to adapt 5/16" and 3/8" steel line to 3/8" fuel hose, 24" of 3/8" fuel hose (SAE 30R7) and four stainless steel worm-type hose clamps.

- Universal Fuel Hose & Filter Kit**.....#8135



#80913

DUAL-QUAD FUEL HOSE KIT

Supplies fuel to two Edelbrock carbs when used on Edelbrock Dual-Quad manifolds. Use with a fuel hose kit such as our #8122 or #8127. 6-7/16" center-to-center, 1/8"-NPT fuel pressure port and a 3/8"-NPT fuel inlet.



#8088

- Dual-Quad Fuel Line Kit (Red anodized finish)**#8088
- Dual-Quad Fuel Line Kit (Endura finish)**.....#8091
- Dual-Quad Fuel Line Kit (ProClassic finish)**#80913



#8091



#73831

FUEL PRESSURE GAUGE

A Pressure Gauge is an important element in getting maximum performance and consistency from your fuel system.

- 1-1/2" Standard Gauge 0-15 psi**.....#73831*

***FOR RACING USE ONLY:** All products with this icon are intended to be used on vehicles that are exclusively designated for racing use only. They are not legal for use on vehicles that are registered for street use.

FUEL HOSE KITS



#8124

FUEL PUMP TO CARB INLET HOSE KITS FOR EDELBROCK FUEL PUMPS WITH 3/8" OUTLET

These high-quality fuel line kits offer a clean and precise fuel supply line for mechanical fuel pumps with a 3/8" NPT outlet, when using an Edelbrock Single- or Dual-Feed fuel inlet kit #8128, #8131, #8133 or #8134. These hose kits are pre-assembled hose with hose ends and are available with stainless steel braided hose or black nylon fabric ProClassic hose. Carb fuel inlet not included.



#8125

Braided Stainless Steel Fuel Hose Kit
(for S/B Chevy, S/B Chrysler, and B/B Chrysler).....#8123

Braided Stainless Steel Fuel Hose Kit
(for AMC, B/B Chevy, S/B Ford, 429/460 Ford & Pontiac).....#8124

Braided Stainless Steel Fuel Hose Kit
(for S/B Fords - bottom feed only).....#8125



#81243

ProClassic Black Fuel Hose Kit
(for S/B Chevy, S/B Chrysler, and B/B Chrysler).....#81233

ProClassic Black Fuel Hose Kit
(for AMC, B/B Chevy, S/B Ford, 429/460 Ford & Pontiac).....#81243



#8123 & #81233



#8102

FUEL PUMP TO CARB HOSE KITS COMPLETE FUEL PUMP TO CARBURETOR FUEL HOSE

These high-quality fuel line kits offer a clean and precise fuel supply line for mechanical fuel pumps with 3/8" NPT to the 5/8" -20 fuel inlet on Edelbrock Performer Series and Thunder Series AVS Carbs. They are manufactured with Russell ProClassic hose and include fuel filter, 5/8" -20 banjo bolt and gaskets. **Will work with OEM or equivalent fuel pumps.**



#8103

ProClassic Fuel Hose with Street Fuel Filter.....#8102

ProClassic Fuel Hose with Competition Fuel Filter.....#8103

CARBURETOR DATA LOG

In order to get the most from your Edelbrock carburetor purchase, please complete and mail the enclosed warranty card. Also, you may want to record your calibration settings in the table below and keep it with your vehicle records.

Model#: _____ **Purchase Date:** _____

Date	Primary Rod	Secondary Jet	Step-Up Jet	Pump Drive Link Spring