



**Performer and Performer RPM Intake Manifolds
For 260-302 c.i.d. Small Block Ford Engines
Catalog #s 2121, 3721, 3723, 7121, 7521 & 75213
INSTALLATION INSTRUCTIONS**

• **DESCRIPTION:**

Edelbrock Performer series intake manifolds are designed for engines operating in the idle to 5500 rpm range. Performer RPM series intake manifolds are designed for engines operating in the 1500-6500 rpm range. Match Performer or Performer RPM intake manifolds with recommended carburetors and additional equipment for even greater performance increases.

APPLICATIONS:

INTAKE MANIFOLD	REFERENCE	APPLICATION
2121	B, C, D	Performer 289: Designed for street 260-289-302 c.i.d. Ford V8s without EGR. Will not fit Boss 302 or 255 c.i.d. V8s.
3721, 3723	B, C, D	Performer 302 4-V (3721) and Performer 302 2-V (3723) - Designed for carbureted 302 c.i.d. Ford V8s with EGR. 3721 replaces the stock 4V EGR manifold using the stock 4v EGR adapter. 3723 includes a 2-bbl EGR plate, allowing the use of the stock 2-bbl carburetor and EGR valve. Both manifolds can be adapted for 4-bbl use by using our #8053 4V EGR plate and the OEM EGR valve and gasket. Our #8017 adapter kit and Ford #E4ZZ9A-589E spacer may be substituted for our 8053 EGR plate. For 4V off-highway, non-EGR applications, use our #8714 spacer.
7121	B, C, D	Performer RPM 302: Designed for 289-302 c.i.d. Ford V8s for high-performance use. No provision for exhaust heated choke. Will not fit 255 c.i.d. V8.
7521, 75213	A, C, D	RPM Air-Gap 302: Designed for 289-302 c.i.d. Ford V8s. Features an Air-Gap design, resulting in a cooler, denser charge for more power. No provisions for exhaust heated chokes and no exhaust crossover.

- A** - Not legal for sale or use on pollution controlled motor vehicles.
- B** - Stock replacement/street legal in some applications. See "Stock Replacement Parts List for Intake Manifolds" insert, or Catalog for details.
- C** - Available in additional finishes, such as polished, PermaStar, or EnduraShine. See Catalog for details.
- D** - Aftermarket 4-bbl carburetors are not compatible with Ford AOD. Performer Series and Thunder Series AVS carbs will work with Ford AOD

- **EGR SYSTEMS:** Edelbrock EGR-equipped *Performer* manifolds are intended as a direct functionally identical replacement for their O.E.M. counterparts. All exhaust emissions or emissions related stock components are intended to be retained and functional. Non-EGR equipped manifolds will not accept stock EGR (Exhaust Gas Recirculation) equipment. EGR systems are used on most 1972 and later model vehicles. Check local laws for requirements.

• **CARBURETOR RECOMMENDATIONS:**

Manifold 2121, 3721, 3723 (Emissions Controlled Applications):

CARBURETOR	REFERENCE	PARTS REQUIRED FOR INSTALLATION
OEM	B, H, N	

Manifold 2121 (Non-Emissions):

CARBURETOR	REFERENCE	PARTS REQUIRED FOR INSTALLATION
Performer #1403 (500 cfm)	A, I, K, N	#1490 or 1845 throttle plate kit, #1483 or 1844 throttle lever adapter
Performer #1404 (500 cfm)	A, I, K, N, O	#1490 or 1845 throttle plate kit, #1483 or 1844 throttle lever adapter
Performer #1405 (600 cfm)	A, I, K, N, O	#1490 or 1845 throttle plate kit, #1483 or 1844 throttle lever adapter
Performer #1406 (600 cfm)	A, I, K, N	#1490 or 1845 throttle plate kit, #1483 or 1844 throttle lever adapter
Thunder Series #1805 (650 cfm)	A, I, K, N	#1490 or 1845 throttle plate kit, #1483 or 1844 throttle lever adapter
Thunder Series #1806 (650 cfm)	A, I, K, N	#1490 or 1845 throttle plate kit, #1483 or 1844 throttle lever adapter
Thunder Series #1825 (650 cfm)	A, I, K, N	#1490 or 1845 throttle plate kit, #1483 or 1844 throttle lever adapter
Thunder Series #1826 (650 cfm)	A, I, K, N	#1490 or 1845 throttle plate kit, #1483 or 1844 throttle lever adapter

Manifold 7121, 7521, 75213 (Non-Emissions):

CARBURETOR	REFERENCE	PARTS REQUIRED FOR INSTALLATION
Performer #1407 (750 cfm)	A, I, K, N, O	#1490 or 1845 throttle plate kit, #1483 or 1844 throttle lever adapter
Performer #1412 (800 cfm)	A, I, K, N, O	#1490 or 1845 throttle plate kit, #1483 or 1844 throttle lever adapter
Performer #1413 (800 cfm)	A, I, K, N	#1490 or 1845 throttle plate kit, #1483 or 1844 throttle lever adapter
Thunder Series #1812 (800 cfm)	A, I, K, N	#1490 or 1845 throttle plate kit, #1483 or 1844 throttle lever adapter
Thunder Series #1813 (800 cfm)	A, I, K, N	#1490 or 1845 throttle plate kit, #1483 or 1844 throttle lever adapter

A - Carburetor will work with non-EGR or pre-emission control systems.

B - Carburetor will work with EGR system.

H - Carburetor has provision for evaporative canister.

I - Carburetor has no provisions for evaporative canister.

K - Carburetor requires #8008 or #8024 stud, washer and nut kit. Determine proper length based on gasket thickness and your accessory mounting requirements.

N - Carburetor accepts factory cruise control

O - Carburetor comes with manual choke. It can be converted to electric choke using kit #1478.

P - Carburetor is not a stock replacement part

- **THROTTLE BRACKETS:** Due to the design of Performer manifolds, the throttle and kickdown bracket on some vehicles may require modification to fit. When using Edelbrock carburetors, use #1490 or 1845 throttle plate kit. See Figure 1.
- **GASKETS:** Do not use competition style intake gaskets for this street manifold. Due to material deterioration over time, internal leakage of vacuum, oil, and coolant may occur.

INTAKE MANIFOLD	RECOMMENDED GASKET
2121, 3721, 3723, 7121, 7521, 75213	Edelbrock #7220 Port: 1.20" x 2.00", .060" Thickness

NOTE: To ensure maximum performance and a proper seal, Edelbrock gaskets which are specifically designed and manufactured for use with Edelbrock parts must be used.

- **PREP AND TUNING FOR POWER:**

NOTE: Local emission laws must be checked for legality of any carburetor or ignition changes.

Performer Series Intake Manifolds

1. The long equal length runners in the Performer manifold create a very strong signal to the carburetor. In some applications, the stock rods or jets may need changing for best overall performance. Refer to your carburetor owner's manual for details.
- 2) Performer manifolds deliver excellent driveability and power utilizing stock distributor settings. Some applications may benefit from resetting the initial advance $\pm 2^\circ$ from the factory specification.
- 3) Aftermarket ignitions and more aggressive advance curves may be used with Performer packages.
- 4) Installation of aftermarket headers or camshafts may lean the carburetor calibration. Should this occur recalibrate with a richer jet.

Performer RPM Series Intake Manifolds

1. Due to design, the fuel / air mixture and cylinder charging are very efficient with Performer RPM or RPM Air-Gap manifolds. Generally speaking, the stock jetting for a Performer Series or Thunder Series carburetor will not need changing. Specific applications may show an increase in power by tuning the fuel mixture.
 2. Aftermarket distributor curve kits may be used with Performer RPM series manifolds.
 3. Use modified or high performance cylinder heads such as our Performer RPM, and port-match the manifold to the heads.
 4. The compression ratio should be at least 9.5 to 1 to work properly with Performer RPM camshafts.
 5. Installation of aftermarket headers, camshafts or both with an Edelbrock Performer RPM series manifold may lean carburetor calibration. Should this condition occur, recalibrate with a richer jet.
- **CAMSHAFT AND HEADERS:** The Performer Series manifolds are compatible with aftermarket camshafts and headers designed to work in the idle-5500 rpm range. Edelbrock has developed a dyno-matched, street proven camshaft (#2122 for 289-302 c.i.d. engines) for use with Performer Series intake manifolds. Header primary tube diameter should be 1-5/8". Performer RPM Series manifolds are compatible with aftermarket camshafts and headers designed to work in the 1500-6500 rpm range. Edelbrock has developed dyno-matched, street proven camshafts (#7122 or 2221 for 289-302 c.i.d. engines) for use with Performer RPM series manifolds (see catalog for details). Header primary tube diameter should be 1-3/4".

INSTALLATION INSTRUCTIONS

- 1) Use only recommended intake gaskets set when installing this intake manifold.
- 2) Fully clean the cylinder head intake flanges and the engine block end seal surfaces.
- 3) Apply Edelbrock Gasgacinch sealant P/N 9300 to both cylinder head flanges and to the cylinder head side of the gaskets, allow to air dry, and attach the intake gaskets.
- 4) Do not use cork or rubber end seals. Use RTV silicone sealer instead. Apply a 1/4" high bead across each block end seal surface, overlapping the intake gasket at the four corners. This method will eliminate end seal slippage.
- 5) Install the intake manifold and hold-down bolts. Torque all of the manifold bolts in two steps by the sequence shown in Figure 2 to 18-20 ft/lbs.

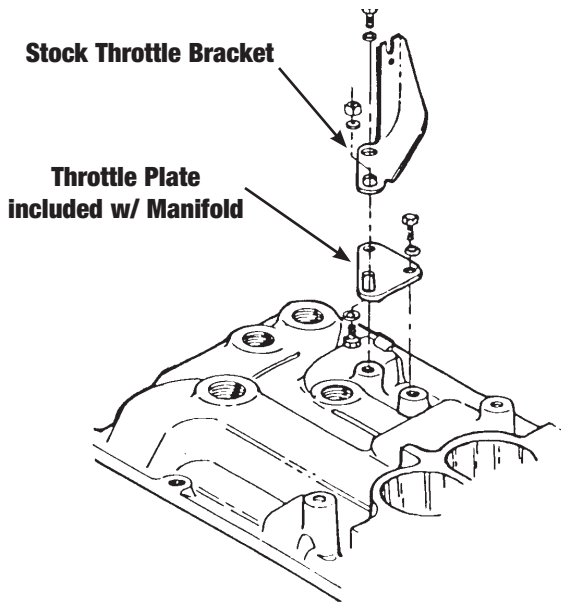

Figure 1 - Throttle Plate

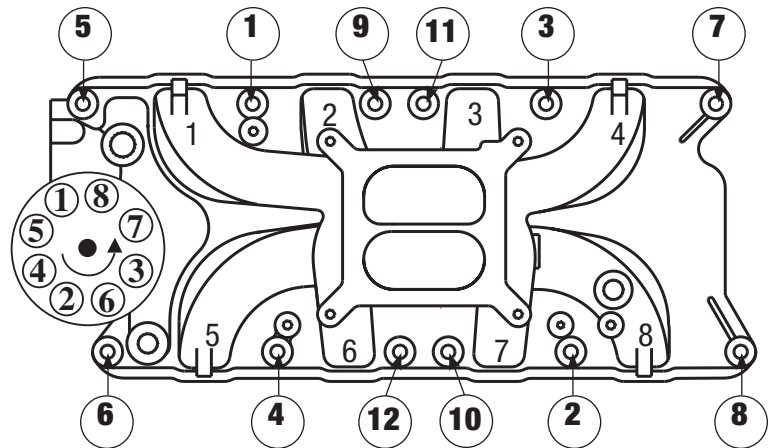

Figure 2 - 260-289-302 Ford Torque Sequence

Torque Bolts to 18-20 ft/lbs.

Firing Order: 1-5-4-2-6-3-7-8

Turn Distributor Clockwise to Advance Ignition Timing